

RESOLUTION NO. 2015-026

A RESOLUTION OF THE TOWN COUNCIL OF THE TOWN OF SOUTHWEST RANCHES, FLORIDA, ACCEPTING THE SELECTION COMMITTEE'S DECISION TO RANK PRESTIGE PROPERTY MAINTENANCE AS THE HIGHEST QUALIFIED PROPOSER FOR TOWN-WIDE IRRIGATION MAINTENANCE SERVICES TO THE TOWN; APPROVING AN AGREEMENT WITH PRESTIGE PROPERTY MAINTENANCE, INC. TO PROVIDE TOWN-WIDE IRRIGATION MAINTENANCE SERVICES TO THE TOWN; APPROVING AN ADDITIONAL EXPENSE NOT TO EXCEED \$12,157 (TWELVE THOUSAND, ONE HUNDRED FIFTY SEVEN DOLLARS) FOR TOWN-WIDE IRRIGATION MAINTENANCE SERVICES, WHICH IS THE PRORATED CONTRACTUAL INCREASE; APPROVING A FY 2014-2015 BUDGETARY APPROPRIATION FROM THE GENERAL FUND AND TRANSPORTATION FUND; AUTHORIZING THE MAYOR, TOWN ADMINISTRATOR AND TOWN ATTORNEY TO ENTER INTO AN AGREEMENT; AND PROVIDING AN EFFECTIVE DATE.

WHEREAS, In September, 2014, the Town, in compliance with the Town's procurement procedures, published a Request for Proposals 14-012 seeking Town-Wide Irrigation Maintenance Services; and

WHEREAS, two (2) companies attended the Town's mandatory pre-proposal conference on October 23, 2014 at 9:00 A.M.; and

WHEREAS, on November 20, 2014, the Town opened the responses that it received from Prestige Property Maintenance, Inc. ("Prestige") and Green Construction Technologies, Inc. (collectively referred to as the "Proposers"); and

WHEREAS, on December 11, 2014, at an advertised public meeting, the Town's Selection Committee ("SC") reviewed the two (2) proposals; and

WHEREAS, on January 6, 2015, at an advertised public meeting, the Town's Selection Committee ("SC") ranked Prestige Property Maintenance, Inc. as the highest qualified proposer; and

WHEREAS, the Town Council hereby confirms the ranking of the SC and authorizes the Town Administrator to enter into an agreement with Prestige; and

WHEREAS, the project is underfunded in the current fiscal year 2014-2015, and the Town desires to provide funds for this project from its General Fund and Transportation Fund; and

WHEREAS, Prestige and the Town desire to enter into an Agreement for the provision of Town-Wide Irrigation Maintenance Services by Prestige under the terms and conditions set forth hereinafter.

NOW, THEREFORE, BE IT RESOLVED BY THE TOWN COUNCIL OF THE TOWN OF SOUTHWEST RANCHES, FLORIDA:

Section 1. The above-referenced recitals are true and correct and are incorporated herein by reference.

Section 2. After reviewing all the information provided, the Town Council hereby accepts the decision of the SC that the highest qualified proposer for Town-Wide Irrigation Maintenance Services is Prestige Property Maintenance, Inc.

Section 3. The Town Council hereby approves an Agreement between the Town of Southwest Ranches and Prestige Property Maintenance, Inc. in substantially the same form as that attached hereto as Exhibit "A", for Town-Wide Irrigation Maintenance Services.

Section 4. In accordance with the Town Charter and the budget adopted in Ordinance No. 2014-006, the FY 2014-2015 budget is hereby amended by increasing the General Fund: Appropriated Fund Balance revenue account 001-0000-399-39900 in the amount of \$12,157; increasing the Transportation Fund: Transfer from the General Fund revenue account 101-0000-381-38101 in the amount of \$10,267; and correspondingly, increasing the General Fund: PROS Department – Ground Maintenance – Parks expense account 001-3600-572-46040 in the amount of \$1,890; increasing the General Fund: Transfer to the Transportation Fund expense account 001-3900-581-91101 in the amount of \$10,267; and increasing the Transportation Fund: Landscaping – Griffin Road Maintenance – expense account 101-5100-541-53110 in the amount of \$10,267.

Section 5. The Town Council and authorizes the Mayor, Town Administrator and Town Attorney to enter into an agreement with Prestige in substantially the same form as that attached hereto as Exhibit "A" and to make such modifications, additions, and/or deletions which they deem necessary and proper to effectuate the intent of this Resolution

Section 6. This Resolution shall take effect immediately upon its adoption.

[Signatures on Following Page]

PASSED AND ADOPTED by the Town Council of the Town of Southwest

Ranches, Florida, this 12th day of February, 2015, on a motion by Council Member McKay and seconded by Council Member Breitkreuz.

Nelson	<u>Absent</u>
Fisikelli	<u>Yes</u>
Breitkreuz	<u>Yes</u>
Jablonski	<u>Yes</u>
McKay	<u>Yes</u>

Ayes	<u>4</u>
Nays	<u>0</u>
Absent	<u>1</u>

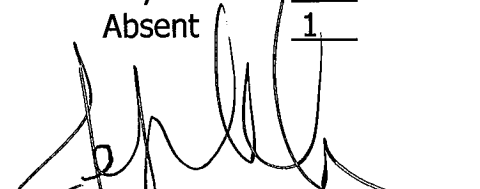

Jeff Nelson, Mayor

ATTEST:



Russell Muñiz, Assistant Town Administrator/Town Clerk

Approved as to Form and Correctness:

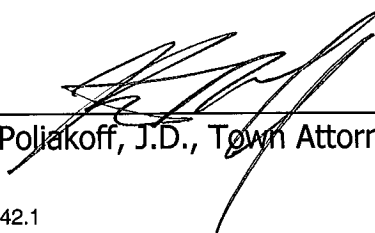

Keith Poliakoff, J.D., Town Attorney

112237442.1

AGREEMENT
BETWEEN THE
TOWN OF SOUTHWEST RANCHES
AND
PRESTIGE PROPERTY MAINTENANCE, INC.
FOR
TOWN-WIDE IRRIGATION MAINTENANCE SERVICES
RFP No. 14- 012

TOWN-WIDE IRRIGATION MAINTENANCE SERVICES
RFP No. 14-012

THIS IS AN AGREEMENT (“Agreement”) made and entered into on this 12th day of February, 2015 by and between the Town of Southwest Ranches, a Municipal Corporation of the State of Florida, (hereinafter referred to as “Town”) and **Prestige Property Maintenance, Inc.** (hereinafter referred to as “Contractor”).

WHEREAS, the Town desires to select a contractor for the purpose of **Town-Wide Irrigation Maintenance Services (“Project”)**; and

WHEREAS, the Town advertised a Request for Proposals, RFP No. 14-012 on September 17, 2014 (“RFP”); and

WHEREAS, Two (2) proposals were received by the TOWN on November 20, 2014; and

WHEREAS, the Town has adopted Resolution No. 2015-026 at a public meeting of the Town Council approving the recommended award and has selected Prestige Property Maintenance Inc. for award of the Project; and

WHEREAS, the proposal submitted to the Town by Contractor is attached to this Agreement as Exhibit “A-1” and made a part hereof.

NOW THEREFORE, in consideration of the foregoing premises and the mutual terms and conditions herein, the Town and Contractor hereby agree as follows:

1. CONTRACT DOCUMENTS/SCOPE OF WORK: The Contract Documents consist of the following documents: Request for Proposals #14-012 (attached herein as Composite Exhibit “B,” hereinafter interchangeably referred to as the “Scope of Services,” “Services,” or “Work” unless otherwise specified), which is incorporated herein by reference and shall be completely integrated and construed as being a specific part of this Agreement, Contractor’s Proposal (Exhibit “A-1”), this Agreement and any written modifications hereto. In the case of a conflict in the Contract Documents, those requiring the more stringent performance by Contractor shall govern. The Contractor shall provide Town-wide Irrigation Maintenance Services for the term of this Agreement, and any approved extensions thereto (as set forth in Section 24 of the RFP). The Work includes but is not limited to the following: furnish all of the labor, materials, equipment services and incidentals necessary to perform all of the Work described and detailed in, or reasonably inferable from, the Contract Documents. Refer also to SCOPE OF SERVICES / SPECIFICATIONS, Sections A-P of the RFP. All Work rendered pursuant to this Agreement by Contractor shall be performed in strict accordance with the applicable standard of care for persons or entities performing similar work in Broward County, Florida. Contractor shall perform the Work in strict accordance with the requirements of this Agreement, all of the other Contract Documents, good construction and/or best management practices for this type of Work performed in Broward County, Florida and all applicable codes, ordinances, rules, laws and regulations governing the Work, including, but not limited to, the Florida Building Code, along with Broward County Amendments to it.

2. LICENSING/PERMITS: Contractor represents that it will maintain at all times during the progress of any Work and any warranty period, all licenses, certificates of competency or other documents required by the Scope of Services evidencing compliance with licensure requirements necessary to practice his profession as required by Florida law, Broward County, and the Town’s Code.

3. INSURANCE: Contractor shall procure and maintain at all times during the performance of this Agreement, including any approved extensions thereof, all insurance coverages required by, and in the manner specified in, Section 9 of the RFP.

4. INDEMNIFICATION: Contractor's indemnification obligations are set forth in Section 16 of the RFP. Contractor further agrees that in claims against any person indemnified hereunder by an employee of Contractor, a subcontractor, anyone directly or indirectly employed by them or anyone for whose acts they may be liable, the indemnification obligations hereunder shall not be limited by a limitation on amount or type or amount of damages, compensation or benefits payable under worker's compensation acts, disability benefits acts, or other employee benefits acts. The Town shall not in any way be answerable or accountable for any violations of applicable laws or for any injury, loss or damage arising from the negligent or intentional act or omission of Contractor or any one of its employees, contractors or agents.

5. CHANGES TO SCOPE OF WORK: The Town shall not accept any change orders from the Contractor for the Project unless approved in writing by the Town. By executing this Agreement, Contractor specifically acknowledges that Contractor has performed its due diligence and will perform the Work for the prices stated in Contractor's Proposal attached hereto, for the term of this Agreement, and any approved extensions thereof.

6. COMPENSATION & METHOD OF PAYMENT

- .1 The amount of compensation payable by the Town to Contractor shall be based upon the rates and schedules (interchangeably referred to as the "Contract Price" or "Agreement Sum") as set forth in Composite Exhibit "B" which amount shall be accepted by Contractor as full compensation for all such work performed under this Agreement. It is acknowledged and agreed by Contractor that these amounts are the maximum payable and constitute a limitation upon Town's obligation to compensate Contractor for its Services related to this Agreement. This maximum amount, however, does not constitute a limitation of any sort, upon Contractor's obligation to perform all items of work required by or which can be reasonably inferred from the Scope of Services.
- .2 The initial rates and schedules have been adopted by the Town Council as part of the Resolution enacting this Agreement. The Town Council, at its own discretion, may increase the rate by subsequent Resolution.
- .3 Town shall pay Contractor in accordance with the Florida Prompt Payment Act. Additionally, payment may be withheld by the Town Administrator, for failure of Contractor to comply with a term, condition or requirement of this Agreement.
- .4 Town shall not be liable for any cost increases or escalation associated with labor, materials, including but not limited to petroleum, that may arise during the performance of the Work. In the event the cost of the Work exceeds the amounts defined herein as the Agreement Sum, Contractor shall pay such excess from its own funds and Town shall not be required to pay any part of such excess. The only exception shall be any adjustments to the Agreement Sum pursuant to any written Change Order duly executed by Town and Contractor in accordance with the terms and conditions of this Agreement, and with the same formality and of equal dignity associated with the original execution of this Agreement.
- .5 Town and Contractor agree that payment under this Agreement will be subject to (a) the delivery of an appropriate invoice by Contractor to Town, and (b) verification by Town that the Work has been performed in accordance with this Agreement. Upon verification by Town that the invoiced Work has been performed in accordance with this Agreement, Town shall have thirty (30) days thereafter to pay said invoice.
- .6 Notwithstanding any provision of this Agreement to the contrary, the Town Administrator may withhold, in whole or in part, payment to the extent necessary to protect itself from loss on account of inadequate or

TOWN-WIDE IRRIGATION MAINTENANCE SERVICES
RFP No. 14-012

defective work of Contractor which has not been remedied or resolved in a manner satisfactory to the Town Administrator. The amount withheld shall not be subject to payment of interest by Town.

- .7 Town reserves the right in the event the primary vendor cannot provide an item(s) or service(s) in a timely manner as requested, to seek other sources without violating the intent of the contract.
- .8 In case of default by Contractor, Town may procure the articles or services from other sources and hold Contractor responsible for any excess costs occasioned or incurred thereby.

7. ASSIGNMENT: Refer to Section 19 of the RFP. No assignment of this Agreement or of the Work hereunder by Contractor shall be valid without the express written consent of the Town Administrator, which may be given or withheld, in Town's sole discretion. All Work to be performed pursuant to this Agreement shall be performed by Contractor, and no Work shall be subcontracted to other parties or firms without the written consent and approval of the Town Administrator.

8. WARRANTIES: Contractor warrants to the Town that all materials, supplies, equipment and Work under this Agreement will be of good quality, free from faults and defects and in conformance with the Contract Documents.

9. CONTRACTOR'S RESPONSIBILITY FOR SAFETY AND TO PROTECT WORK: Contractor shall be responsible for initiating, maintaining and supervising all safety precautions and programs in connection with the Work provided pursuant to this Agreement in order to prevent, inter alia, damage, injury or loss to (a) all employees performing the Work and all other persons who may be affected thereby, (b) all the Work and all materials and equipment to be incorporated therein and (c) other property at the site or adjacent thereto. Contractor shall timely provide all notices and comply with all applicable laws, ordinances, rules, regulations and orders of any public authority or other authority with jurisdiction bearing on the safety of persons and property in order to provide protection from damage injury or loss. Contractor shall also take reasonable steps to protect the Work and any adjacent or immediately surrounding property against all loss or damage, and shall promptly repair any damage done from any cause whatsoever. If such loss or damage is caused by Contractor's failure to properly protect or perform the Work or is otherwise caused from Contractor's intentional or negligent actions or omissions, such repairs shall be without cost or expense to the Town. In the event that the loss or damage is caused solely by an employee or agent of the Town and could not reasonably be avoided by Contractor's reasonable efforts to protect the Work or surrounding property, then the Town and Contractor shall negotiate a reasonable cost to repair the damage, and such costs shall be accounted for through the issuance of a change order to this Agreement.

10. DEFECTIVE WORK: Contractor shall promptly correct or remove, at its sole expense, any defective Work and replace it with non-defective Work. Contractor shall pay all direct, indirect, and consequential costs of such removal or correction.

11. DEFAULT/TERMINATION FOR CAUSE: Refer to Section 22 of the RFP.

11.1. In addition, the occurrence of any one or more of the following events will justify Town's termination of Contractor for cause:

- .1 Contractor's performance of defective work or persistent failure to perform the Work in strict accordance with the Contract Documents (including, but not limited to, failure to supply sufficient skilled workers or suitable materials or equipment);

TOWN-WIDE IRRIGATION MAINTENANCE SERVICES
RFP No. 14-012

- .2 Contractor's disregard of Laws or Regulations of any public body having jurisdiction state or federal laws;
 - .3 Violation of Town's policies and procedures, including Contractor's disregard of the authority of the Town, including the Contract Manager;
 - .4 Contractor's violation of any provisions of the Contract Documents;
 - .5 Contractor's Abandonment of the Work;
 - .6 Contractor's insolvency, bankruptcy, or assignment for the benefit of creditors.
- 11.2. If one or more of the events identified in paragraph 11.1 occur, Town may, after giving Contractor thirty (30) days written notice, terminate the services of Contractor.
- 11.3 Where Contractor's services have been so terminated by Owner, the termination will not affect any rights or remedies of the Town against Contractor then existing or which may thereafter accrue. Any retention or payment of moneys due Contractor by Town will not release Contractor from liability.
- 11.4 If, after notice of termination of Contractor's right to proceed, it is found that Contractor was not in default or that sufficient grounds for termination for cause did not exist, the termination shall be deemed automatically converted to one for convenience, and the rights and obligations of the Town and Contractor shall be the same as if the notice of termination were issued pursuant to Section 13 below.

12. TERMINATION FOR CONVENIENCE: Refer to Section 22.2 of the RFP.

12.1. The Agreement may be terminated for convenience in writing by the Town, without cause and without prejudice to any other right or remedy of Town, upon thirty (30) days written notice to Contractor of its intent to terminate and the date on which such termination becomes effective. In such case, Contractor shall be paid (without duplication of any items) for:

- .1 Completed and acceptable work executed in accordance with the Contract Documents prior to the effective date of termination, including fair and reasonable sums for overhead and profit on such Work, provided however, that Contractor must first provide Town with sufficient back-up documentation for such Work;
 - .2 Expenses sustained prior to the effective date of termination in performing services and furnishing labor, materials, or equipment as required by the Contract Documents, plus fair and reasonable sums for overhead and profit on such expenses;
- 12.2 Under no circumstances shall payment include, or Town be liable for, lost or anticipated profit for Work or services not performed, nor for indirect, special or consequential damages of any kind.

13. INTERPRETATION:

13.1. Entire Agreement. This Agreement, including the Contract Documents, constitutes the entire agreement of the parties with respect to the subject matter hereof. No other agreements, oral or written,

pertaining to the Work to be performed under this Agreement exist between the parties. This Agreement may be modified only by a written change order signed by both parties.

13.2. **Governing Law.** This Agreement shall be interpreted and governed in accordance with the laws of the State of Florida.

14. ATTORNEYS' FEES AND COSTS: If any party to this Agreement brings a cause of action against the other party arising from or relating to this Agreement the prevailing party in such proceeding shall be entitled to recover reasonable attorney's fees, experts fees, and court costs (at both the trial and appellate levels).

15. CONTRACTOR'S PERFORMANCE:

15.1 Contractor shall not subcontract any portion of the work required by this Agreement, except with the prior approval of the Town Administrator, which shall be in his sole and absolute discretion. If subcontractors are to be used during the term of this Agreement, a list of such subcontractors shall be provided to the Town Administrator, subject to his approval.

15.2 Contractor agrees to perform its Work in a professional manner and in accordance with all applicable Local, State, County, and Federal laws, rules, ordinances, regulations and codes. Contractor agrees that the Work provided shall be provided by employees that are legally employable in the United States of America, educated, trained, experienced, certified, and licensed in all areas encompassed within their designated duties. Contractor agrees to furnish to TOWN any and all documentation, certifications, authorizations, licenses, permits, or registrations currently required by applicable laws, rules, and regulations. Contractor further certifies that it and its employees will keep all licenses, permits, registrations, authorizations, or certifications required by applicable laws or regulations in full force and effect during the term of this Agreement. Contractor represents that all persons performing the services required under this Agreement have the knowledge and skills, either by training, experience, education, or a combination thereof, to adequately and competently perform the duties, obligations, and services set forth herein in a skillful and respectable manner.

15.3 Failure of Contractor to comply with this paragraph shall constitute a material breach of this Agreement.

16. DISPUTE RESOLUTION: Refer to Section 11 of the RFP.

16.1 To prevent all disputes and litigation, it is agreed by the parties hereto that the Town Administrator or his designee shall decide all questions, claims, difficulties and disputes of whatever nature which may arise relative to the technical interpretation of the Contract Documents and fulfillment of this Agreement as to the character, quality, amount and value of any Work done and materials furnished, or proposed to be done or furnished under or, by reason of, the Contract Documents and such decisions of all claims, questions, difficulties and disputes shall be final and binding, subject to judicial resolution.

16.2 During the pendency of any dispute and after a determination thereof, Contractor and Town shall act in good faith to mitigate any potential damages.

16.3. In the event the determination of a dispute under this Section 16 is unacceptable to either party hereto, the party objecting to the determination must notify the other party in writing within ten (10) calendar days of receipt of the written determination. The notice must state the basis of the objection and must be accompanied by a statement that any adjustment claimed is the entire adjustment to which the objecting party has reason to believe it is entitled to as a result of the determination. Within sixty (60) calendar days thereafter, the parties shall participate in mediation to address all objections to any determinations hereunder and to attempt to prevent litigation. Neither party shall commence litigation prior to the expiration of the sixty (60) day mediation period. The mediator shall be mutually agreed upon by the parties. Should any objection not be resolved in mediation, the parties retain all their legal rights and remedies provided under State law. **A PARTY SPECIFICALLY WAIVES ALL OF ITS RIGHTS, INCLUDING BUT NOT LIMITED TO CLAIMS FOR PRICE ADJUSTMENTS, PROVIDED IN THE CONTRACT DOCUMENTS, INCLUDING ITS RIGHTS AND REMEDIES UNDER STATE LAW, IF SAID PARTY FAILS TO COMPLY IN STRICT ACCORDANCE WITH THE REQUIREMENTS OF THIS SECTION. Contractor and Town hereby waive any rights to a trial by jury.**

17. AUDIT OF PROJECT RECORDS: Town shall have the right to audit the books, records and accounts of Contractor that are related to this Agreement. Contractor shall keep such books, records, and accounts as may be necessary in order to record complete and correct entries related to this Agreement. Contractor shall preserve and make available, at reasonable times for examination and audit by Town, all financial records, supporting documents, statistical records, and any other documents pertinent to this Agreement for the required retention period of the Florida Public Records Act (Chapter 119, Florida Statutes), if applicable, or, if the Florida Public Records Act is not applicable, for a minimum period of the later of three (3) years after termination or expiration of this Agreement, unless Contractor is notified in writing by Town of the need to extend the retention period. Such retention of such records and documents shall be at Contractor's sole expense. If any audit has been initiated and audit findings have not been resolved at the end of the retention period or the three (3) year period, whichever is later, the books, records, and accounts shall be retained until resolution of the audit findings. If the Florida Public Records Act is determined by Town to be applicable to Contractor's records, Contractor shall comply with all requirements thereof; however, no confidentiality or non-disclosure requirement of either federal or state law shall be violated by Contractor. Any incomplete or incorrect entry in such books, records, and accounts shall be a basis for Town's disallowance and recovery of any payment upon such entry. In addition, Contractor shall respond to the reasonable inquiries of successor Contractors and allow successor Contractors to receive working papers relating to matters of continuing significance. In addition, Contractor shall provide a complete copy of all working papers to the Town, prior to final payment by the Town under this Agreement.

18. DIFFERING SITE CONDITIONS: In the event that during the course of the Work, Contractor encounters subsurface or concealed conditions which differ materially from those shown on the Contract Documents and from those ordinarily encountered and generally recognized as inherent in work of the character called for in the Contract Documents; or unknown physical conditions of an unusual nature, which differ materially from that ordinarily encountered and generally recognized as inherent in work of the character called for in the Contract Documents, Contractor without disturbing the conditions and before performing any Work affected by such conditions, shall, within twenty-four (24) hours of their discovery, notify Contract Manager in writing of the existence of the aforesaid conditions. Contract Manager shall investigate the site conditions identified by Contractor. If, in the sole opinion of Contract Manager, the conditions do materially so differ and cause an increase or decrease in Contractor's cost of, or the time required for, the performance of any part of the Work, whether or not charged as a result of the conditions, Contract Manager may recommend an equitable adjustment to the Contractor's compensation hereunder. If Contract Manager and Contractor cannot agree on an adjustment

in the compensation, the adjustment shall be referred to the Town Administrator for determination in accordance with the provisions of Section 18 above. No request by Contractor for an equitable adjustment to the Agreement under this provision shall be allowed unless Contractor has given written notice to the Contract Manager in strict accordance with the provisions of this Section.

19. LOCATION AND DAMAGE TO EXISTING FACILITIES, EQUIPMENT OR UTILITIES:

19.1. Town does not guarantee that all lines are shown, or that the ones indicated are in their true location. It shall be the Contractor's responsibility prior to commencement of any Work to identify and locate all underground and overhead utility lines or equipment affecting or affected by the Work. No additional payment will be made to the Contractor because of discrepancies in actual and planned location of utilities, and additional costs suffered as a result thereof.

19.2. The Contractor shall notify each utility company involved at least thirty (30) days prior to the start of construction to arrange for positive underground location, relocation or support of its utility where that utility may be in conflict with or endangered by the proposed construction. Relocation of water mains or other utilities for the convenience of the Contractor shall be paid by the Contractor. All charges by utility companies for temporary support of its utilities shall be paid for by the Contractor. All costs of permanent utility relocation to avoid conflict shall be the responsibility of the utility company involved. No additional payment will be made to the Contractor for utility relocations, whether or not said relocation is necessary to avoid conflict with other lines.

19.3. The Contractor shall schedule the Work in such a manner that the Work is not delayed by the utility providers relocating or supporting their utilities. The Contractor shall coordinate its activities with any and all public and private utility providers occupying the right-of-way. No compensation will be paid to the Contractor for any loss of time or delay.

19.4. All overhead, surface or underground structures and utilities encountered are to be carefully protected from injury or displacement. All damage to such structures is to be completely repaired within a reasonable time; needless delay will not be tolerated. The Town reserves the right to remedy such damage by ordering outside parties to make such repairs at the expense of the Contractor. All such repairs made by the Contractor are to be made to the satisfaction of the utility owner. All damaged utilities must be replaced or fully repaired. All repairs are to be inspected by the utility owner prior to backfilling.

19.5. The foregoing provisions of this Section 19 relating to costs and/or delays incurred by Contractor due to underground structures and utilities are subject to Section 18 above; provided however, that under no circumstances shall Contractor be entitled to an equitable adjustment in compensation where Contractor knew or could have discovered through the exercise of due diligence, the existence and/or location of such underground structures and utilities.

20. NOTIFICATION OF CLAIM FOR CHANGE OF CONTRACT PRICE OR DAMAGES:

Any claim for a change in compensation or for damages shall be made by written notice by Contractor to the Contract Manager within five (5) calendar days of the commencement of the event giving rise to the claim or knowledge by Contractor of the claim and the notice shall state the general nature and cause of the claim. Thereafter, within twenty (20) calendar days of the termination of the event giving rise to the claim or knowledge of the claim, written notice of the extent of the claim with supporting information and documentation shall be submitted to the Contract Manager (hereinafter "Claim Notice"). The Claim Notice shall include Contractor's written notarized certification that the adjustment claimed is the entire adjustment to which the Contractor has

TOWN-WIDE IRRIGATION MAINTENANCE SERVICES
RFP No. 14-012

reason to believe it is entitled as a result of the occurrence of said event. If the Contract Manager and Contractor cannot resolve a claim as set forth in a proper Claim Notice within twenty (20) calendar days after receipt by the Contract Manager, then Contractor shall submit the claim to Town Administrator within ten (10) calendar days from the date of impasse in accordance with Section 16 above. **IT IS EXPRESSLY AND SPECIFICALLY AGREED THAT ANY AND ALL CLAIMS FOR CHANGES TO CONTRACT PRICE SHALL BE WAIVED IF NOT SUBMITTED IN STRICT ACCORDANCE WITH THE REQUIREMENTS OF THIS SECTION.**

21. NOTICES: Whenever either party desires to give notice to the other, such notice must be in writing by certified or registered mail, postage prepaid, return receipt requested, hand delivery, or facsimile transmission prior to 5:00 p.m. on the date of transmission (e.d.t. or e.s.t. as applicable), or via overnight express courier service. For the present, the parties designate the following individuals as the respective parties and places for the giving of notice:

If to Town:

Town of Southwest Ranches
Town Administrator
13400 Griffin Road
Southwest Ranches, Florida 33330

With a copy to:

Keith M. Poliakoff, J.D.
Arnstein & Lehr
200 East Las Olas Boulevard
Suite 1700
Fort Lauderdale, Florida 33301

If to Contractor:

Greg Lica, Controller
Prestige Property Maintenance Inc.
3300 SW 46 Avenue
Davie, Florida 33314

22. GOVERNING LAW AND VENUE: Refer to Section 21 of the RFP.

23. SEVERABILITY: Refer to Section 25 of the RFP.

24. SOVEREIGN IMMUNITY: Nothing in this Agreement is intended nor shall it be construed or interpreted to waive or modify the Town's Sovereign Immunity defense or any other of the Town's immunities and limitations on liability as provided for in the Florida Statutes, as now worded or as may hereafter be amended, and all Florida case law interpreting same.

25. FUNDING: The obligation of Town for payment to Contractor for the Work is limited to the availability of funds appropriated in a current fiscal period, and continuation of any contractual relationship into a subsequent fiscal period is subject to appropriation of funds, unless otherwise authorized by law. In the event the funds to finance the Work under this Agreement become unavailable, Town may provide Contractor with thirty (30) days written notice of termination. Nothing in this Agreement shall be deemed or construed to

TOWN-WIDE IRRIGATION MAINTENANCE SERVICES
RFP No. 14-012

prevent the parties from negotiating a new Agreement in this scenario. In the event that Town elects to terminate Contractor for lack of funds as provided for in this paragraph, and Town's termination for lack of funds is later determined by a court of competent jurisdiction to be improper, or in any other way wrongful or in breach of this Agreement, the termination shall automatically be deemed converted to a termination for convenience and Contractor shall be paid solely in accordance with Section 12 above.

26. PUBLIC RECORDS: The Town is subject to Chapter 119, Florida Statutes, "Public Records Law." No claim of confidentiality or proprietary information in all or any portion of a response will be honored unless a specific exemption from the Public Records Law exists and it is cited in the response. An incorrectly claimed exemption does not disqualify the firm, only the exemption claimed. Contractor understands that the public shall have access, at all reasonable times, to all documents and information pertaining to Town's contracts, subject to the provisions of Chapter 119, Florida Statutes, and agrees to allow access by the Town and the public to all documents subject to disclosures under applicable law. Contractor's failure or refusal to comply with the provisions of this Section shall result in the immediate cancellation and/or termination of this Agreement by Town. To the extent that Contractor has been provided access to or has received security sensitive information, as defined by Florida Statutes, Section 119.071 and/or has executed a Confidential Information Acknowledgement and Agreement as part of the proposal process, Contractor shall keep and maintain the security sensitive information as confidential and exempt from public disclosures as required by Florida Statutes.

27. PUBLIC ENTITY CRIMES INFORMATION STATEMENT: Pursuant to Florida Statutes, Section 287.133: "A person or affiliate who has been placed on the convicted vendor list following a conviction for a public entity crime may not submit a bid, proposal, or reply on a contract to provide any goods or services to a public entity; may not submit a bid, proposal, or reply on a contract with a public entity for the construction or repair of a public building or public work; may not submit bids, proposals, or replies on leases of real property to a public entity; may not be awarded or perform work as a contractor, supplier, subcontractor, or consultant under a contract with any public entity; and may not transact business with any public entity in excess of the threshold amount provided in s. 287.017 for CATEGORY TWO for a period of 36 months following the date of being placed on the convicted vendor list." Violation of this Section by Contractor shall result in Town's immediate termination of this Agreement.

28. NO WAIVER OF RIGHTS: Neither the Town's review, approval or payment for any of the Work required under this Agreement shall be construed to operate as a waiver of any of Towns rights or remedies under this Agreement or of any causes of action arising out Contractor's performance of the Work under this Agreement, and Contractor shall be and remain liable to the Town for all damages to the Town caused by the Contractor's negligent or improper performance of any of the Work furnished under this Agreement, irrespective of the Town's review, approval or payment for any of the Work under this Agreement. The rights and remedies of the Town provided for under this Agreement are in addition to all other rights and remedies provided to Town by law or in equity.

29. WAIVER OF RIGHT TO JURY TRIAL: BY ENTERING INTO THIS AGREEMENT, CONTRACTOR AND TOWN HEREBY EXPRESSLY WAIVE ANY RIGHTS EITHER PARTY MAY HAVE TO A TRIAL BY JURY IN ANY CIVIL LITIGATION RELATED TO, OR ARISING OUT OF THIS AGREEMENT.

30. NO AMENDMENT OR WAIVER: This Agreement may not be changed, altered or modified except by an instrument in writing signed by all parties hereto, with the same formality and of equal dignity as the execution of this Agreement prior to the initiation of any Work reflecting such change.

31. CHAPTER 558, FLORIDA STATUTES, NOT APPLICABLE. The parties understand and agree that Chapter 558, Florida Statutes, does not apply to this Agreement or the Work, and that the parties hereby “opt out” of the procedures set forth at Chapter 558, Florida Statutes.

32. MISCELLANEOUS:

- A. Ownership of Documents.** Unless otherwise provided by law, any and all reports, surveys, and other data and documents provided or created in connection with this Agreement by Contractor and all persons or entities employed or otherwise retained by Contractor are and shall remain the property of Town. In the event of termination of this Agreement for any reason, any reports, photographs, surveys and other data and documents prepared by Contractor, whether finished or unfinished, shall become the property of Town and shall be delivered by Contractor to the Town Administrator within seven (7) days of termination of this Agreement for any reason. Any compensation due to Contractor shall be withheld until all documents are received by Town as provided herein.
- B. Independent Contractor.** Contractor is an independent contractor of Town under this Agreement. Services provided by Contractor pursuant to this Agreement shall be subject to the supervision of Contractor. In providing such services, neither Contractor nor its agents shall act as officers, employees or agents of the Town. Personnel policies, tax responsibilities, social security and health insurance, employee benefits, purchasing policies and other similar administrative procedures applicable to the Work and services rendered under this Agreement shall be exclusively and solely those of Contractor. This Agreement shall not constitute or make Town and Contractor a partnership or joint venture.
- C. Conflicts.** Neither Contractor nor its employees shall have or hold any continuing or frequently recurring employment or contractual relationship that is substantially antagonistic or incompatible with Contractor’s loyal and conscientious exercise of judgment related to its performance under this Agreement.

Contractor agrees that none of its officers or employees shall, during the term of this Agreement, serve as an expert witness against Town in any legal or administrative proceeding in which he or she is not a party, unless compelled by court process. Further, Contractor agrees that such persons shall not give sworn testimony or issue a report or writing, as an expression of his or her expert opinion, which is adverse or prejudicial to the interests of Town in connection with any such pending or threatened legal or administrative proceeding. The limitations of this Section shall not preclude Contractor or any other persons from representing themselves in any action or in any administrative or legal proceeding.

In the event Contractor is permitted to utilize subcontractors to perform any services required by this Agreement, Contractor agrees to prohibit such subcontractors, by written contract, from having any conflicts within the meaning of this paragraph C of Section 32.

- D. Contingency Fee.** Contractor warrants that it has not employed or retained any company or person, other than a bona fide employee working solely for Contractor, to solicit or secure this Agreement and that it has not paid or agreed to pay any person, company, corporation, individual or firm, other than a bona fide employee working solely for Contractor, any fee, commission, percentage, gift, or other consideration contingent upon or resulting from the award or making of this Agreement. For a breach or violation of this provision, Town shall have the right to terminate this Agreement without liability and, at its discretion, to deduct from the Contract Price or otherwise recover the full amount of such fee, commission, percentage, gift or consideration.

- E. Materiality and Waiver of Breach.** Town and Contractor agree that each requirement, duty, and obligation set forth herein is substantial and important to the formation of this Agreement and, therefore, is a material term hereof. Town's failure to enforce any provision of this Agreement shall not be deemed a waiver of such provision or modification of this Agreement. A waiver of any breach of a provision of this Agreement shall not be deemed a waiver of any subsequent breach and shall not be construed to be a modification or continuing waiver of the terms of this Agreement.
- F. Joint Preparation.** Town and Contractor both acknowledge that they have sought and received whatever competent advice and legal counsel as was necessary for them to form a full and complete understanding of all rights and obligations herein and that the preparation of this Agreement has been their joint effort. The language agreed to herein express their mutual intent and the resulting document shall not, solely as a matter of judicial construction, be construed more severely against one of the parties over the other.
- G. Drug-Free Workplace.** Contractor agrees that it shall maintain a drug-free workplace as set forth in the RFP.
- H. Headings.** Headings are for convenience of reference only and shall not be considered in any interpretation of this Agreement.
- I. Binding Authority.** Each person signing this Agreement on behalf of either party individually warrants that he or she has full legal power to execute this Agreement on behalf of the party for whom he or she is signing, and to bind and obligate such party with respect to all provisions contained in this Agreement.
- J. Truth-in-Negotiation Certificate.** Signature of this Agreement by Contractor shall act as the execution of a truth-in-negotiation certificate stating that wage rates and other factual unit costs supporting the compensation of this Agreement are accurate, complete, and current at the time of contracting.

[SIGNATURES ON NEXT PAGE]

TOWN-WIDE IRRIGATION MAINTENANCE SERVICES
RFP No. 14-012

IN WITNESS WHEREOF, the parties have made and executed this Agreement on the respective dates under each signature: PRESTIGE PROPERTY MAINTENANCE, INC., and the TOWN OF SOUTHWEST RANCHES, signing by and through its Mayor duly authorized to execute same by Council action on the 12th day of February 2015.

WITNESSES:

Susan Kutz
Susan Kutz
Juanita Romance
Juanita Romance

PRESTIGE PROPERTY MAINTENANCE, INC.

By: [Signature]
Greg Lica, Controller
26 day of January 2015

TOWN OF SOUTHWEST RANCHES

By: [Signature]
Jeff Nelson, Mayor
12th day of February 2015

By: [Signature]
Andrew D. Berns, Town Administrator
12th day of February 2015

ATTEST:

[Signature]
Russell Muñiz, MMC, Town Clerk

APPROVED AS TO FORM AND CORRECTNESS:

[Signature]
Keith M. Poliakoff, Town Attorney
IWOV-ACTIVE.FID1670820



CERTIFICATE OF LIABILITY INSURANCE

DATE (MM/DD/YYYY)
1/26/2015

THIS CERTIFICATE IS ISSUED AS A MATTER OF INFORMATION ONLY AND CONFERS NO RIGHTS UPON THE CERTIFICATE HOLDER. THIS CERTIFICATE DOES NOT AFFIRMATIVELY OR NEGATIVELY AMEND, EXTEND OR ALTER THE COVERAGE AFFORDED BY THE POLICIES BELOW. THIS CERTIFICATE OF INSURANCE DOES NOT CONSTITUTE A CONTRACT BETWEEN THE ISSUING INSURER(S), AUTHORIZED REPRESENTATIVE OR PRODUCER, AND THE CERTIFICATE HOLDER.

IMPORTANT: If the certificate holder is an ADDITIONAL INSURED, the policy(ies) must be endorsed. If SUBROGATION IS WAIVED, subject to the terms and conditions of the policy, certain policies may require an endorsement. A statement on this certificate does not confer rights to the certificate holder in lieu of such endorsement(s).

PRODUCER CKP Insurance LLC 21845 Powerline Road Suite 205 Boca Raton, FL 33433	CONTACT NAME: PHONE (A/C, No, Ext): (561) 807-0900	FAX (A/C, No): (561) 826-3782	
	E-MAIL ADDRESS: Public@ckpinsurance.com		
INSURED Prestige Property Mgmt & Main., Inc. & Prestige Property Maintenance Inc dba 3300 SW 46th Avenue Davie, FL 33314	INSURER(S) AFFORDING COVERAGE		NAIC #
	INSURER A : American Fire and Casualty Company		24066
	INSURER B : Ohio Security Insurance Company		24082
	INSURER C :		
	INSURER D :		
	INSURER E :		

COVERAGES **CERTIFICATE NUMBER:** **REVISION NUMBER:**

THIS IS TO CERTIFY THAT THE POLICIES OF INSURANCE LISTED BELOW HAVE BEEN ISSUED TO THE INSURED NAMED ABOVE FOR THE POLICY PERIOD INDICATED. NOTWITHSTANDING ANY REQUIREMENT, TERM OR CONDITION OF ANY CONTRACT OR OTHER DOCUMENT WITH RESPECT TO WHICH THIS CERTIFICATE MAY BE ISSUED OR MAY PERTAIN, THE INSURANCE AFFORDED BY THE POLICIES DESCRIBED HEREIN IS SUBJECT TO ALL THE TERMS, EXCLUSIONS AND CONDITIONS OF SUCH POLICIES. LIMITS SHOWN MAY HAVE BEEN REDUCED BY PAID CLAIMS.

INSR LTR	TYPE OF INSURANCE	ADDL INSD	SUBR WVD	POLICY NUMBER	POLICY EFF (MM/DD/YYYY)	POLICY EXP (MM/DD/YYYY)	LIMITS
A	<input checked="" type="checkbox"/> COMMERCIAL GENERAL LIABILITY <input type="checkbox"/> CLAIMS-MADE <input checked="" type="checkbox"/> OCCUR GEN'L AGGREGATE LIMIT APPLIES PER: <input type="checkbox"/> POLICY <input type="checkbox"/> PRO-JECT <input type="checkbox"/> LOC OTHER:			BLA(15)55927968	02/18/2014	02/18/2015	EACH OCCURRENCE \$ 1,000,000 DAMAGE TO RENTED PREMISES (Ea occurrence) \$ 100,000 MED EXP (Any one person) \$ 5,000 PERSONAL & ADV INJURY \$ 1,000,000 GENERAL AGGREGATE \$ 2,000,000 PRODUCTS - COMP/OP AGG \$ 2,000,000
B	<input checked="" type="checkbox"/> AUTOMOBILE LIABILITY <input type="checkbox"/> ANY AUTO <input type="checkbox"/> ALL OWNED AUTOS <input type="checkbox"/> HIRED AUTOS <input type="checkbox"/> SCHEDULED AUTOS <input type="checkbox"/> NON-OWNED AUTOS			BAS55927968	02/18/2014	02/18/2015	COMBINED SINGLE LIMIT (Ea accident) \$ 1,000,000 BODILY INJURY (Per person) \$ BODILY INJURY (Per accident) \$ PROPERTY DAMAGE (Per accident) \$
	<input type="checkbox"/> UMBRELLA LIAB <input type="checkbox"/> EXCESS LIAB <input type="checkbox"/> DED <input type="checkbox"/> RETENTION \$						EACH OCCURRENCE \$ AGGREGATE \$
	<input type="checkbox"/> WORKERS COMPENSATION AND EMPLOYERS' LIABILITY <input type="checkbox"/> ANY PROPRIETOR/PARTNER/EXECUTIVE OFFICER/MEMBER EXCLUDED? (Mandatory in NH) If yes, describe under DESCRIPTION OF OPERATIONS below						<input type="checkbox"/> PER STATUTE <input type="checkbox"/> OTH-ER E.L. EACH ACCIDENT \$ E.L. DISEASE - EA EMPLOYEE \$ E.L. DISEASE - POLICY LIMIT \$

DESCRIPTION OF OPERATIONS / LOCATIONS / VEHICLES (ACORD 101, Additional Remarks Schedule, may be attached if more space is required)

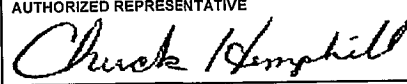
CERTIFICATE HOLDER Town of Southwest Ranches 13400 Griffin Road Southwest Ranches, FL 33330	CANCELLATION SHOULD ANY OF THE ABOVE DESCRIBED POLICIES BE CANCELLED BEFORE THE EXPIRATION DATE THEREOF, NOTICE WILL BE DELIVERED IN ACCORDANCE WITH THE POLICY PROVISIONS. AUTHORIZED REPRESENTATIVE 
---	--



CERTIFICATE OF LIABILITY INSURANCE

DATE (MM/DD/YYYY)

01/26/2015

THIS CERTIFICATE IS ISSUED AS A MATTER OF INFORMATION ONLY AND CONFERS NO RIGHTS UPON THE CERTIFICATE HOLDER. THIS CERTIFICATE DOES NOT AFFIRMATIVELY OR NEGATIVELY AMEND, EXTEND OR ALTER THE COVERAGE AFFORDED BY THE POLICIES BELOW. THIS CERTIFICATE OF INSURANCE DOES NOT CONSTITUTE A CONTRACT BETWEEN THE ISSUING INSURER(S), AUTHORIZED REPRESENTATIVE OR PRODUCER, AND THE CERTIFICATE HOLDER.

IMPORTANT: If the certificate holder is an ADDITIONAL INSURED, the policy (ies) must be endorsed. If SUBROGATION IS WAIVED, subject to the terms and conditions of the policy, certain policies may require an endorsement. A statement on this certificate does not confer rights to the certificate holder in lieu of such endorsement(s).

PRODUCER FrankCrum Insurance Agency, Inc. 100 South Missouri Avenue Clearwater, FL 33756	CONTACT NAME:		
	PHONE (A/C, No, Ext): 1-800-277-1620 x4800	FAX (A/C, No): (727) 797-0704	
	E-MAIL ADDRESS:		
INSURED FrankCrum L/C/F Prestige Property Management & Maintenance, Inc. 100 South Missouri Avenue Clearwater, FL 33756	INSURER(S) AFFORDING COVERAGE		NAIC#
	INSURER A: Frank Winston Crum Insurance Co.		11600
	INSURER B:		
	INSURER C:		
	INSURER D:		
	INSURER E:		

COVERAGES **CERTIFICATE NUMBER:** 308535 **REVISION NUMBER:**

THIS IS TO CERTIFY THAT THE POLICIES OF INSURANCE LISTED BELOW HAVE BEEN ISSUED TO THE INSURED NAME ABOVE FOR THE POLICY PERIOD INDICATED. NOTWITHSTANDING ANY REQUIREMENT, TERM OR CONDITION OF ANY CONTRACT OR OTHER DOCUMENT WITH RESPECT TO WHICH THIS CERTIFICATE MAY BE ISSUED OR MAY PERTAIN, THE INSURANCE AFFORDED BY THE POLICIES DESCRIBED HEREIN IS SUBJECT TO ALL THE TERMS, EXCLUSIONS AND CONDITIONS OF SUCH POLICIES. LIMITS SHOWN MAY HAVE BEEN REDUCED BY PAID CLAIMS.

INSR LTR	TYPE OF INSURANCE	ADDL INSRD	SUBR WVD	POLICY NUMBER	POLICY EFF (MM/DD/YYYY)	POLICY EXP (MM/DD/YYYY)	LIMITS	
	GENERAL LIABILITY <input type="checkbox"/> COMMERCIAL GENERAL LIABILITY <input type="checkbox"/> CLAIMS-MADE <input type="checkbox"/> OCCUR GEN'L AGGREGATE LIMIT APPLIES PER: <input type="checkbox"/> POLICY <input type="checkbox"/> PROJECT <input type="checkbox"/> LOC						EACH OCCURRENCE \$ DAMAGE TO RENTED PREMISES (Ea occurrence) \$ MED EXP (Any one person) \$ PERSONAL & ADV INJURY \$ GENERAL AGGREGATE \$ PRODUCTS-COMP/OP AGG \$	
	AUTOMOBILE LIABILITY <input type="checkbox"/> ANY AUTO <input type="checkbox"/> ALL OWNED AUTOS <input type="checkbox"/> SCHEDULED AUTOS <input type="checkbox"/> HIRED AUTOS <input type="checkbox"/> NON-OWNED AUTOS						COMBINED SINGLE LIMIT (Ea accident) \$ BODILY INJURY (Per person) \$ BODILY INJURY (Per accident) \$ PROPERTY DAMAGE (Per accident) \$	
	<input type="checkbox"/> UMBRELLA LIAB <input type="checkbox"/> OCCUR <input type="checkbox"/> EXCESS LIAB <input type="checkbox"/> CLAIMS-MADE <input type="checkbox"/> DED <input type="checkbox"/> RETENTION \$						EACH OCCURRENCE \$ AGGREGATE \$	
A	WORKERS COMPENSATION AND EMPLOYERS' LIABILITY ANY PROPRIETOR/PARTNER/EXECUTIVE OFFICER/MEMBER EXCLUDED? <input type="checkbox"/> Y/N (Mandatory In NH) If yes, describe under DESCRIPTION OF OPERATIONS below	N/A		WC201500000	01/01/2015	01/01/2016	<input checked="" type="checkbox"/> WC STATUTORY LIMITS <input type="checkbox"/> OTH-ER E.L. EACH ACCIDENT \$1,000,000 E.L. DISEASE-EA EMPLOYEE \$1,000,000 E.L. DISEASE-POLICY LIMIT \$1,000,000	

DESCRIPTION OF OPERATIONS / LOCATIONS / VEHICLES (Attach ACORD 101, Additional Remarks, Schedule, if more space is required)

Effective 12/26/2007, coverage is for 100% of the employees of FrankCrum leased to Prestige Property Management & Maintenance, Inc. (Client) for whom the client is reporting hours to FrankCrum. Coverage is not extended to statutory employees.

CERTIFICATE HOLDER**CANCELLATION**

Town of Southwest Ranches 13400 Griffin Rd. Southwest Ranches, FL 33330	SHOULD ANY OF THE ABOVE DESCRIBED POLICIES BE CANCELLED BEFORE THE EXPIRATION DATE THEREOF, NOTICE WILL BE DELIVERED IN ACCORDANCE WITH THE POLICY PROVISIONS.
	AUTHORIZED REPRESENTATIVE 

TOWN OF SOUTHWEST RANCHES



REQUEST FOR PROPOSALS

Town-Wide Irrigation Maintenance Services

RFP No. 14-012

Date: September 17, 2014

PROPOSAL SET & DOCUMENTS

TOWN OF SOUTHWEST RANCHES REQUEST FOR PROPOSALS NO: 14-012

September 17, 2014

TOWN OF SOUTHWEST RANCHES, FLORIDA
TOWN-WIDE IRRIGATION MAINTENANCE SERVICES

TABLE OF CONTENTS

TABLE OF CONTENTS	3
CONTRACT DATA	4
PUBLIC NOTICE OF REQUEST FOR PROPOSALS	5
GENERAL CONDITIONS & INSTRUCTIONS TO PROPOSERS	6
SCOPE OF SERVICES / SPECIFICATIONS	13
MAINTENANCE FREQUENCIES*	18
PROPOSAL FORMS	19
MAINTENANCE PROPOSAL: PRICE LIST BY ZONE / SERVICE CATEGORY	19
(BASE PROPOSAL):	19
IRRIGATION MAINTENANCE – ROADS	19
IRRIGATION MAINTENANCE - PARKS AND OTHER FACILITIES	19
MAINTENANCE PROPOSAL: PRICE LIST BY SERVICE (AUXILIARY SERVICES)	20
IRRIGATION SYSTEM COMPONENTS (FURNISH AND INSTALL):	20
OTHER REQUIRED SIGNATURES AND SUBMITTALS	22
PROPOSAL SECURITY	22
CONTRACTOR QUALIFICATIONS	22
PROFESSIONAL ORGANIZATIONS	22
CONFLICTS OF INTEREST	22
DRUG FREE WORKPLACE	23
PUBLIC ENTITY CRIMES	24
SWORN STATEMENT PURSUANT TO SECTION 287.133(3)(a), FLORIDA STATUTES, ON PUBLIC ENTITY CRIMES	25
NON-COLLUSIVE AFFIDAVIT	27
CERTIFICATE OF AUTHORITY (If Individual / Sole Proprietor)	28
CERTIFICATE OF AUTHORITY (If Corporation or Limited Liability Company)	29
CERTIFICATE OF AUTHORITY (If Partnership)	30
CERTIFICATE OF AUTHORITY (If Joint Venture)	31
PROPOSER QUALIFICATION	32
GOVERNMENTAL CONTACT INFORMATION	33
SUBCONTRACTORS	34
PROPOSED MANAGEMENT PLAN	35
PROPOSER DISCLOSURE OF LITIGATION HISTORY	36
STATEMENT OF NO RESPONSE	37
ATTACHMENTS AND EXHIBITS:	38
ATTACHMENT "A" – AGREEMENT FORM – TO BE EXECUTED AFTER AWARD OF CONTRACT	38
EXHIBITS - GRIFFIN ROAD EAST AND WEST IRRIGATION PLANS	38

TOWN OF SOUTHWEST RANCHES, FLORIDA
TOWN-WIDE IRRIGATION MAINTENANCE SERVICES

CONTRACT DATA

Contract Owner: Town of Southwest Ranches ("Town")

Contract Title: Town-Wide Irrigation Maintenance Services

Contract Number: Town Request for Proposals No. 14-012

Contract Address: 13400 Griffin Road
Southwest Ranches, FL 33330

Mandatory Pre-Proposal Conference: Thursday, October 23, 2014, 9:00 AM

Last Date for Questions/Clarification: Thursday, November 6, 2014, 5:00 PM

Proposal Submission Due: Thursday, November 20, 2014, 11:00 AM

Cone of Silence Applicable. (See page 6)

Town Council: Jeff Nelson, Mayor
Gary Jablonski, Vice Mayor
Steve Breitkreuz, Council Member
Freddy Fisikelli, Council Member
Doug McKay, Council Member

Owner's Representative: Andrew D. Berns,
Town Administrator
13400 Griffin Road
Southwest Ranches, FL 33330
Phone: 954 434 0008 / Fax: 954 434 1490

Contract Manager: Clete J. Saunier
Public Works Director/Town Engineer

Contract Coordinator: December Lauretano-Haines
PROS Coordinator
13400 Griffin Road
Southwest Ranches, FL 33330
Phone: 954 434 0008 / Fax: 954 434 1490

TOWN OF SOUTHWEST RANCHES, FLORIDA
TOWN-WIDE IRRIGATION MAINTENANCE SERVICES

PUBLIC NOTICE OF REQUEST FOR PROPOSALS

The Town of Southwest Ranches, Florida, hereinafter referred to as TOWN, will receive sealed Proposals at the Office of Juanita Romance, Town Procurement and Special Projects Coordinator, Town of Southwest Ranches, 13400 Griffin Road, Southwest Ranches, Florida, 33330 until **11:00 AM, Thursday, November 20, 2014**, at which time they will be publically opened and read for:

**TOWN-WIDE IRRIGATION MAINTENANCE SERVICES
REQUEST FOR PROPOSAL NO.: 14-012**

This Request for Proposals (RFP) for Town-Wide Irrigation Maintenance Services includes the furnishing of all labor, materials, tools, equipment, machinery and services for proper maintenance which for the purposes of this RFP, shall include but not be limited to irrigation maintenance and repair services and other miscellaneous work as described herein.

A mandatory pre-proposal conference will be held on **Thursday, October 23, 2014**, starting at **9:00 AM**. Location is at Southwest Ranches Town Hall, 13400 Griffin Road, Southwest Ranches, Florida, 33330. Proposal Specifications are available on Onvia/DemandStar and the Town of Southwest Ranches Website: <http://www.southwestranches.org/procurement/>. Proposals will not be accepted from firms that do not attend the pre-proposal conference.

In accordance with Florida Statutes, Section 119.071, proposals are exempt from public disclosure until such time as the Town provides notice of an intended award or until 30 days after the opening, whichever is earlier.

The Town reserves the right to reject any or all Proposals, to award multiple or partial contracts, to waive any informality, non-material irregularity or technicality in any Proposal, to re-advertise for Proposals, or take any other such actions that may be deemed to be in the best interests of the Town.

The Town will complete a Proposal Award analysis that will look for any unbalanced Proposals to ensure that unit prices are within industry standards and that the Proposers are not charging excessive unit prices for those items the Town will utilize the most.

Andrew D. Berns
Town Administrator

GENERAL CONDITIONS & INSTRUCTIONS TO PROPOSERS

1. SECURITY AND BONDING REQUIREMENTS:

1.1 PROPOSAL SECURITY

Simultaneous with the delivery of an executed Proposal to the Town, Proposer (also referred to as Contractor throughout this RFP) shall furnish to the Town a Proposal Security in an amount equal to five percent (5%) of the total annual amount proposed for all services. The Proposal Security shall be issued in the form of a bond issued by a Surety authorized to transact business in the State of Florida, having an authorized agent in the State of Florida, or in the form of cash, cashier's check payable to the Town of Southwest Ranches, Florida and drawn on a Florida Bank, or in the form of an irrevocable letter of credit or other alternative form of security acceptable to the Town. Failure to supply Proposal Security with the Proposal at the time of Proposal opening shall automatically disqualify the Proposer as non-responsive.

2. PRE-PROPOSAL CONFERENCE

2.1. A mandatory pre-proposal conference will take place on Thursday, October 23, 2014, starting at 9:00 AM. Location is Southwest Ranches Town Hall, 13400 Griffin Road, Southwest Ranches, Florida, 33330.

2.2. Attendees of the mandatory pre-proposal conference will be required to verify their attendance by signature. Proposals will not be accepted from Proposers not present at the pre-proposal conference.

2.3. No pleas of ignorance by the Proposer, of conditions that exist or that may hereinafter exist, as a result of failure to make the necessary examinations or investigations or failure to fulfill in every detail the requirements of the Contract Documents, will be accepted as a basis for varying the requirements of the Town or the compensation of the Proposer.

3. PURPOSE OF PROPOSAL: The Town intends to make an award to the responsive, and responsible Proposer(s) whose proposal is determined to be the most advantageous to the Town, and in accordance with the evaluation factors set forth in this RFP and the Town's Procurement Code.

4. PROPOSER WARRANTY: Proposer warrants that the prices, terms and conditions quoted in the Proposal will be firm for a period of 365 days from the date of the Proposal opening.

5. CONVICTED VENDOR: Pursuant to the provisions of paragraph (2) (a) of section 287.133, Florida Statutes- "A person or affiliate who has been placed on the convicted vendor list following a conviction for a public entity crime may not submit a Proposal on a contract to provide any goods or services to a public entity, may not submit a Proposal on a contract with a public entity for the construction or repair of a public building or public work, may not submit Proposals on leases of real property to a public entity, may not be awarded to perform work as a contractor, supplier, subcontractor, or consultant under a contract with any public entity, and may not transact business with any public entity in excess of the threshold amount provided in Section 287.107, for CATEGORY TWO for a period of 36 months from the date of being placed on the convicted vendor list".

6. QUESTIONS PERTAINING TO PROPOSAL: All questions or clarifications concerning this RFP shall be submitted in writing by mail, facsimile or E-mail and directed to Juanita Romance, Procurement and Special Projects Coordinator, Town of Southwest Ranches, 13400 Griffin Road, Southwest Ranches, FL, 33330. Fax number is (954) 434-1490. E-mail address is jromance@southwestranches.org. Questions will be received no later than Thursday, November 6, 2014 at 5:00 PM. The Proposal Title/RFP number shall be referenced on all correspondence and in the subject section of the email. NO QUESTIONS WILL BE RECEIVED AFTER THE DEADLINE.

6.1. Responses to questions, if deemed necessary by the Town, will be sent to all prospective Proposers in writing, via Onvia/DemandStar and the Town website in the form of an addendum, if applicable. Proposers shall not rely upon oral representations or discussions with the Town, including its staff or consultants. Only those communications issued by the Town in writing may be considered its duly authorized expression. Only Proposer's communications in writing, signed and timely-submitted, shall be recognized by the Town as duly authorized expressions.

6.2. CONE OF SILENCE: A cone of silence is hereby imposed and made applicable to this RFP. The cone of silence shall become effective from the time this RFP is advertised, and shall terminate at the time that the Town Council makes a final decision regarding a contract award, rejects all responses, or takes other action which ends the RFP

TOWN OF SOUTHWEST RANCHES, FLORIDA
TOWN-WIDE IRRIGATION MAINTENANCE SERVICES

process. During the effective time period of the cone of silence, any person or entity which submits a response, or that will be subject to evaluation under the terms of this RFP, shall not have any communication with the members of the Town Council or the Selection Committee relative to this RFP, except as may be required during such presentations or interviews which may be conducted. NOTE: Proposers that violate the cone of silence shall be subject to automatic disqualification from further consideration.

7. TAXES: Proposer should not include taxes in the prices of the Proposal. The Town is exempt from Florida sales tax on direct purchases of tangible property or services.

8. SUBMISSION OF PROPOSALS: A total of six (6) paper copies (1 unbound original and 5 bound copies) and 1 CD electronic copy (.pdf) of the Proposal, in its entirety including all Required Signatures and Submittals, must be received sealed and clearly marked with the RFP "Name and No. 14-012" at the location shown on the Public Notice of Request for Proposals on or before the closing hour and date shown on the Public Notice of Request for Proposals. Proposals submitted by facsimile or electronic mail will not be accepted.

8.1. It is the responsibility of the Proposer to ensure that the Proposal reaches the Office of the Procurement and Special Projects Coordinator on or before the closing hour and date shown on the Public Notice of Request for Proposals. Proposals received after the closing hour and date shown on the Public Notice of Request for Proposals will not be considered and will be returned unopened.

8.2. PROPOSAL FORMS: Proposers must use the Proposal form(s) furnished by the Town. Failure to do so may cause the Proposal to be rejected. Removal or replacement of any of the proposal forms may invalidate the Proposal.

8.3. Proposals having erasures or corrections must be initialed by the Proposer in ink. Proposals shall be signed in ink; all quotations shall be typewritten or filled in with ink. No submissions in pencil will be accepted.

8.4. Incomplete, unresponsive, irresponsible, vague, and ambiguous responses to the RFP will be cause for rejection, as determined by the Town.

8.5. MISTAKE: If there is a discrepancy in the unit and extended prices, the unit prices(s) will prevail and the price extensions will be adjusted to coincide. Proposers are responsible for checking their calculations. Failure to do so will be at the Proposer's risk, and errors will not release the Proposer from his responsibility as noted herein.

8.6. GUARANTEES: No guarantee or warranty is given or implied by the Town as to the total amount of services that may or may not be purchased from any resulting contract or award. The quantities and frequencies provided herein are for proposal purposes only and will be used for tabulation and presentation of the Proposal. The Town reserves the right to increase or decrease service quantities and frequencies, as deemed necessary to serve the best interests of the Town.

8.7 WITHDRAWAL: After Proposals are opened, they shall be irrevocable for a period of ninety (90) days. Proposers who unilaterally withdraw a proposal without permission of the Town before 90 days have elapsed from the date of the opening may be debarred and are subject to forfeiture of the Proposal Security.

9. LIABILITY, INSURANCE, LICENSING & PERMITS: Where Proposers are required to enter onto Town of Southwest Ranches property to deliver materials or to perform work or services as a result of a Proposal award, the Proposer will assume the full duty, obligation, and expense of obtaining all necessary licenses, permits, inspections, and insurances required. The Proposer shall be liable for any damages or loss to persons and property within the Town occasioned by the negligent or intentional actions of the Proposer (including his agent, any person or subcontractor the Proposer has hired in the completion of his contract as a result of the Proposal, and anyone else for whose actions Proposer is responsible).

9.1. Contractor shall be required to furnish a certified copy of all licenses, certificates of competency or other documents evidencing compliance with licensure requirements necessary to practice his profession as required by Florida law, Broward County, and the Town's Code. These documents shall be furnished to the Town along with the Proposal response. Failure to furnish these documents or to have required licensure will be grounds for being deemed non-responsive and rejecting the Proposal.

TOWN OF SOUTHWEST RANCHES, FLORIDA
TOWN-WIDE IRRIGATION MAINTENANCE SERVICES

9.2. At Contractor's sole cost and expense, Contractor shall at all times during the term of this Agreement keep and maintain in full force and effect, on behalf of itself and any sub-contractors it may employ, insurance coverages of the types and amounts equal to 100% of the requirements set forth below.

9.3. Prior to issuance of any contract(s) or proposal award document(s), and/or beginning the performance of work pursuant hereto, and at any time upon request, Contractor shall furnish to the Town, on behalf of itself and any sub-contractors it may employ, Certificates of Insurance or Endorsements evidencing the minimum required coverages and conditions specified below.

9.4. All insurance shall be issued by companies having rating of "A" or higher, with a financial size category of at least Class VII or better per A.M. Best's Key Rating Guide, latest edition and authorized to issue insurance in the State of Florida, and having agents upon whom service of process may be made in Broward County, Florida.

9.5. Such insurance shall not diminish Contractor's indemnification obligations hereunder. The insurance policy shall be issued by such company, in such forms and with such limits of liability and deductibles as are acceptable to the Town and shall be endorsed to be primary over any insurance the Town may maintain.

9.6. Evidence of coverage shall meet the following requirements at a minimum:

9.6.1. Comprehensive form, Commercial General Liability ("CGL") insurance including: Premises-Operations, Underground Hazard, Products-Completed Operations Hazard, Contractual Insurance, Broad Form Property Damage, and Independent Contractors' liability coverages for bodily injury and property damage with minimum limit of liability in an amount not less than One Million Dollars (\$1,000,000) Combined Single Limit Per Occurrence and in the Aggregate of Two Million Dollars (\$2,000,000) for bodily injury and property damage.

9.6.2. Comprehensive form, Automobile Liability insurance including Owned, Hired, Non-Owned, Borrowed and Any Auto liability coverages for Bodily Injury, Property Damage and Death with minimum limit of liability in an amount not less than One Million Dollars (\$1,000,000) Combined Single Limit per Occurrence and in the Aggregate for bodily injury and property damage.

9.6.3. Workers compensation insurance for all employees of the Contractor as required by the laws of the State of Florida including section 440, Florida Statutes, as may be amended from time to time.

9.6.4. All policies shall be appropriately endorsed for contractual liability and also contain a waiver of subrogation endorsement.

9.6.5. All insurance policies referred to herein shall be without any deductible amount.

[INTENTIONALLY LEFT BLANK]

TOWN OF SOUTHWEST RANCHES, FLORIDA
TOWN-WIDE IRRIGATION MAINTENANCE SERVICES

9.6.6. The following shall be named as "additional insured" and listed as Certificate Holder(s) with respect to this coverage:

ADDITIONAL INSURED / CERTIFICATE HOLDER(S):

TOWN OF SOUTHWEST RANCHES

Attention: Andrew D. Berns, Town Administrator
13400 Griffin Road
Southwest Ranches, FL 33330

BROWARD COUNTY BOARD OF COUNTY COMMISSIONERS

115 S Andrews Avenue
Fort Lauderdale, FL

9.7. Coverage specified is not to cease and is to remain in full force and effect (subject to cancellation notice) for the entire duration of any contract award.

9.8. It shall be the responsibility of the Contractor and insurer to furnish to the Town and Broward County copies of renewal policies at least thirty (30) days prior to the expiration date of any insurance coverages due to expire during the term of such contract.

9.9. All policies insuring the Contractor which relate to the activities of such Contractor and the Town must be endorsed to provide the Town and Broward County with not less than thirty (30) days' written notice of cancellation, lapse, restriction, material modification or alteration. It shall be the responsibility of the Contractor and insurer to provide such notification to the Town and Broward County in writing, submitted to the Town Administrator. This requirement shall be reflected on the Certificate of Insurance.

9.10. Failure to fully and satisfactorily comply with the insurance requirements set forth herein will authorize the Town Administrator to implement a rescission of the contract award within thirty (30) days of awarding. The Proposer hereby holds the Town harmless and agrees to indemnify Town and covenants not to sue the Town by virtue of such rescission.

9.11. The Town reserves the right from time to time to change the insurance coverage and limits of liability required to be maintained by Contractor hereunder.

10. AWARD OF PROPOSALS: The Town reserves the right to accept or reject any and/or all Proposals or parts of Proposals, to award multiple or partial contracts, to waive any informality, irregularities or technicalities, to re-advertise for Proposals, or take any other actions that may be deemed to be in the best interests of the Town. The Town also reserves the right to award the contract on a split order basis, in such combination(s) as will best serve the interests of the Town, unless otherwise stated. The Town also reserves the right to waive minor variations to or irregularities in the specifications. Final determination and award of a contract shall be made by the Town Council. Additionally, the Town reserves the right to modify the scope of the services and the Contract to add zones identified in this RFP, and which the Town, in its sole discretion, may not initially require the selected Contractor to perform.

10.1. PROPOSAL CONSIDERATIONS: The Town, at its sole discretion, reserves the right to inspect any/all Proposer's facilities to determine their capability of meeting the requirements set forth herein. Price, Proposer's responsibility and responsiveness, experience, staffing, equipment, materials, references, and past history of service to the Town and/or with other units of State, and/or Local governments in Florida, or comparable private entities, including litigation history, may be taken into consideration.

10.2. SELECTION PROCESS

At the opening date and time set forth herein, the Procurement and Special Projects Coordinator will publicly open and read aloud the names of all respondents, as well as any other information regarding individual submittals that may be deemed necessary by the Town. The opening of proposals is open to the public.

TOWN OF SOUTHWEST RANCHES, FLORIDA
TOWN-WIDE IRRIGATION MAINTENANCE SERVICES

10.2.1. The Town will evaluate all Proposals utilizing a Selection Committee (SC) process. The SC will evaluate and rank the Proposals received in accordance with the requirements of this RFP and the Town's Procurement Code. The SC will analyze Proposals to ensure that unit prices are within industry standards and that the Proposers are not charging excessive unit prices for those items the Town will utilize the most. The SC may require an interview or presentation to assist their evaluation of the services and prices being offered.

10.2.2. The Town intends to make an award to the responsive, and responsible Proposer(s) whose proposal is determined to be the most advantageous to the Town, and in accordance with the evaluation factors set forth at section 10.3 and the Town's Procurement Code.

10.3. **EVALUATION OF PROPOSALS:** Proposals shall be weighted using the following point system basis of evaluation:

Proposals shall be weighted using the following percentage basis of evaluation for proposals:		Points
(1)	Price (Proposal Forms);	50 points
(2)	Experience and tenure of Proposer's assigned Project Manager or Work Crew Supervisor relative to this Proposal for Town-Wide Irrigation Maintenance Services;	15 points
(3)	Proposed Management Plan for the Town, including commitment of dedicated crews and equipment to the Town, structure of services to be provided, including table of organization and auxiliary services offered;	10 points
(4)	Past and present performance, including as disclosed by references provided;	10 points
(5)	Price of auxiliary services from Maintenance Proposal: Price List By Service.	10 points
(6)	Professional Certifications and memberships.	5 points
TOTAL POINTS		100

11. DISPUTES/CONTINUING PERFORMANCE: If any dispute concerning a question of fact arises under any contract award, other than termination for default or convenience, the contractor and the Town Administrator shall make a good faith effort to resolve the dispute informally. If the dispute cannot be resolved by agreement, then the Town Administrator with the advice of the Town Attorney shall resolve the dispute and send a written copy of its decision to the Contractor, which shall be binding on both parties for the duration of the project, subject to judicial review following completion of the project. During the period of any dispute, the Contractor shall continue performance of the work without delay or interruption, and the Town shall continue to make payments to the Contractor pursuant to the terms hereof and any contract award.

12. CANCELLATION: Failure on the part of the Contractor to comply with the conditions, specifications, requirements, and terms hereof as determined by the Town, shall be just cause for cancellation of the award.

13. RELATION TO PARTIES: It is understood and agreed that nothing contained herein shall be deemed to create a partnership, or joint venture. Contractor shall be in the relation of an independent contractor and is to have entire charge, control and supervision of the work to be performed hereunder.

14. COMPLIANCE WITH LAW: Contractor shall comply with all laws, regulations and ordinances of any Federal, State, or Local Governmental authority having jurisdiction with respect to work hereunder (Applicable Laws) and shall obtain and maintain any and all permits, licenses, approvals and consents necessary for the lawful conduct of the activities contemplated hereunder.

15. WAIVER OF LIABILITY/INDEMNITY: The Town shall not in any way be answerable or accountable for any violations of applicable laws or for any injury, loss or damage arising from the negligent or intentional act or omission of Contractor or any one of its employees, contractors or agents.

16. INDEMNIFICATION: The Contractor shall, to the fullest extent permitted by law, indemnify, defend and hold harmless the Town, its Council Members, officers, employees, and agents from any and all claims, liabilities, demands, damages, losses and costs, including, but not limited to, reasonable attorney's fees at both trial and appellate levels, to the extent caused by the negligence, recklessness, or intentional wrongful misconduct of the Contractor and persons employed or utilized by the Contractor in the performance of the work hereunder and anyone else for whose actions Contractor is responsible.

TOWN OF SOUTHWEST RANCHES, FLORIDA
TOWN-WIDE IRRIGATION MAINTENANCE SERVICES

16.1. In addition to the provisions set forth in Article 16, above, Contractor shall indemnify and hold harmless Broward County, its Commissioners, officers, employees, and agents from any and all claims, liabilities, demands, damages, losses, and costs, including but not limited to, reasonable attorney's fees at both the trial and appellate levels, to the extent caused by negligence, recklessness or intentional wrongful misconduct of Contractor and persons employed or utilized by Contractor in the performance of the work hereunder and anyone else for whose actions Contractor is responsible. These indemnification obligations shall survive the term of any contract award or the earlier termination thereof. In the event that any action or proceeding is brought against Broward County by reason of any such claim or demand, Contractor shall, upon written notice from Broward County, resist and defend such action or proceeding by counsel satisfactory to Broward County.

16.2. The indemnification provided in section 16.1 above shall obligate Contractor to defend at its own expense to and through appellate, supplemental or bankruptcy proceeding, or to provide for such defense, at Town's or Broward County's option, any and all claims of liability and all suits and actions of every name and description covered by Section 16.1 above which may be brought against Town and/or Broward County.

17. SECONDARY/OTHER VENDORS: The Town reserves the right in the event the primary Contractor/vendor cannot provide an item(s) or service(s) in a timely manner as requested, to seek other sources without violating the intent of the RFP or any contract award.

18. DEFAULT PROVISION: In case of a default by the Proposer, the Town may, with or without terminating any contract award, procure the articles or services from other sources and hold the Proposer responsible for any excess costs occasioned or incurred thereby.

19. ASSIGNMENT: This RFP and any contract award shall be binding upon and shall inure to the benefit of the Town and to any and all of its successors and assigns, whether by merger, consolidation, transfer of substantially all assets or any similar transaction. Notwithstanding the foregoing, this RFP and any contract award is personal to the Contractor and it may not, either directly or indirectly, assign its rights or delegate its obligations to Town hereunder without first obtaining the Town's consent in writing. Any such attempted assignment or delegation shall be deemed of no legal force and effect whatsoever.

20. NOTICES: All notices and other communications required or permitted are to be given hereunder by either party to the other shall be in writing and shall be sent (except as otherwise provided herein) (i) by certified or registered mail, first class postage prepaid, return receipt requested, (ii) by guaranteed overnight delivery by a nationally recognized courier service, or (iii) by facsimile with confirmation receipt (with a copy simultaneously sent by certified or registered mail, first class postage prepaid, return receipt requested or by overnight delivery by traditionally recognized courier service), addressed to such party as follows: Town Administrator, Town of Southwest Ranches, 13400 Griffin Road, Southwest Ranches, FL 33330.

21. GOVERNING LAW: The validity of this RFP and any contract award, and the interpretation and performance of all of its terms shall be construed and enforced in accordance with the laws of the State of Florida, without regard to principles of conflict of laws thereof. The venue of any action or proceeding commenced under or pursuant hereto or any contract award shall be solely in the State courts in and for Broward County, Florida.

22. REMEDIES FOR BREACH / TERMINATION: The quality and acceptance of workmanship will be determined during site inspections by the Town. Areas that are determined to be unacceptable shall be corrected by the Contractor, at no additional compensation, within twenty-four (24) hours of notification. The Contractor shall not be compensated for the correction of deficient work, nor shall Contractor be entitled to any time extension in connection therewith. The Town reserves the right to correct said unacceptable workmanship if the Contractor does not correct said deficiency within 24 hours. The Town reserves the right to deduct the cost to correct unacceptable workmanship along with \$100 per hour administrative costs from the Contractor's monthly invoice. Unacceptable work shall be deducted from the monthly invoice based on line items in the Proposal Forms.

TOWN OF SOUTHWEST RANCHES, FLORIDA
TOWN-WIDE IRRIGATION MAINTENANCE SERVICES

22.1. Should Contractor fail to perform, Town shall notify Contractor in writing of such failure and Contractor shall have thirty (30) days thereafter to cure such failure. If Contractor is unable or unwilling to cure such failure to perform, then Town shall receive a refund equal to the actual cost of a third party to cure such failure and may immediately terminate any contract award for default. In the event of any litigation arising out of or relating hereto, the prevailing party shall be entitled to an award of its attorney's fees and costs at both the trial and appellate levels.

22.2. Additionally, the Town shall have the right to terminate the contract for convenience upon thirty (30) days written notice. In the event of a termination for convenience, the Town shall pay for services provided by the Contractor through the effective date of the termination, but shall have no further liability or responsibility to the Contractor, and Contractor hereby waives any and all claims for additional compensation and damages, including but not limited to loss of anticipated profits on work not performed. In the event a termination for default is later determined by a court of competent jurisdiction to be wrongful or without cause, the termination shall automatically be deemed one for convenience and Contractor's sole compensation shall be in accordance with this section.

23. WRITTEN CONTRACT: The successful Proposer shall be required to enter into a written contract with the Town (referred to throughout this RFP as a contract award), attached hereto as "Attachment A," the form of which shall be prepared by the Town, and shall incorporate the terms of this advertisement along with the accepted Proposal, and other terms which may be required by the Town.

24. CONTRACT TERM / EXTENSIONS: The Town hereby requests Proposals for a three (3) year contract for supplies and services. In addition, the Town, in its sole discretion, reserves the right to extend the contract for one additional two (2) year term with all terms, conditions and specifications remaining the same if the extension is approved by the Town.

25. SEVERABILITY: If any provision of this RFP, including any contract award, is determined by a court of competent jurisdiction to be invalid or unenforceable, such provision shall be deemed severable from the remaining portions thereof which shall be fully enforceable as if the invalid or unenforceable provision had not been included.

[INTENTIONALLY LEFT BLANK]

TOWN OF SOUTHWEST RANCHES, FLORIDA
TOWN-WIDE IRRIGATION MAINTENANCE SERVICES

SCOPE OF SERVICES / SPECIFICATIONS

DESCRIPTION FOR TECHNICAL SPECIFICATIONS

The Town of Southwest Ranches (Town) located in Southwest Broward County, is approximately 13 square miles and is home to over 7,344 residents.

The Town is a rural environment, filled with grazing animals, nurseries, farms, and exquisite and unique scenery and an abundance of wildlife.

The Town is a unique and environmentally sensitive area inasmuch as individual property owners provide their own potable water via underground wells.

The Town's roads consist of rural section two-lane local roads and rural section collector roads with Right-of-Way widths.

The Town is currently responsible for the maintenance of 82 miles of these types of roads. There are curbs and gutters and segments of sidewalk. Pedestrian and equestrian trails are abundant throughout the Town and in many cases are incorporated along road Rights-of-Way.

The Town owns approximately 160 acres of property. The property is incorporated into 8 park properties in various stages of development or non-development, dedicated to recreational usage, and 3 additional properties used for public services and administration.

The Town operates a multi-use, non-vehicular recreational trail system along its roadways and adjacent roadways by cooperative agreement with landowners or by direct ownership through public Rights-of-Way. The trail system is in various stages of development or non-development.

A. SUMMARY OF SERVICES

This RFP for Town-Wide Irrigation Maintenance Services includes the furnishing of all labor, materials, tools, equipment, machinery and services for proper maintenance which for the purposes of this Proposal, shall include but not be limited to irrigation maintenance and repair services and other miscellaneous work as described herein.

B. EQUIPMENT

All equipment shall be maintained in an efficient and safe operating condition while performing work under the contract. Equipment shall have all proper safety devices required by law, properly maintained and in use at all times. If equipment does not contain proper safety devices and/or is being operated in an unsafe manner, the Town may direct the Contractor to remove such equipment and/or the operator until the deficiency is corrected to the satisfaction of the Town. The Contractor shall be solely responsible and liable for injury to persons, and/or property damage caused by operation of the equipment. The Town reserves the right to inspect and evaluate all of the Contractors' equipment prior to contract award, but is not required to do so. Such inspection is solely for the benefit of the Town.

C. EQUIPMENT STORAGE AND MOBILIZATION

The Contractor must be fully capable of servicing the Town's needs, and providing all of the materials and equipment to fulfill the requirements of this RFP and shall be responsible for the storage of all materials and equipment at Contractor's sole expense. Storage shall not be permitted at any of the sites specified herein or at/on any other Town properties without written permission of the Town.

TOWN OF SOUTHWEST RANCHES, FLORIDA
TOWN-WIDE IRRIGATION MAINTENANCE SERVICES

D. GENERAL REQUIREMENTS

1. The Contractor shall comply with all OSHA safety requirements while performing the work subject to this RFP. All personnel performing the work subject to this RFP will be required to wear Level 2 International Safety Equipment Association (ISEA) approved vests. Any employee of the Contractor improperly prepared to meet this requirement shall be dismissed until proper equipment is secured.
2. No fuel, oils, solvents, or similar materials are to be disposed of in any catch basins or on the ground. The Contractor must closely adhere to all local, state, and Federal Environmental Protection Agency requirements, and is responsible for all non-compliance penalties, and any site cleanup. Contractor further agrees to indemnify, defend and hold Town harmless from any such penalties and any injury or damage resulting from such non-compliance.
3. All debris removed from Town must be legally disposed of according to the Town's Code of Ordinances and in accordance with Local, State and Federal Regulations.
4. The Contractor will be responsible for design, set-up and Maintenance of Traffic (MOT) operations for work being performed within public rights-of-way. MOT plans are to be submitted to the Town for approval prior to implementation. MOT plans shall be prepared by MOT-certified personnel and must be in accordance with and conform to the current edition of the FDOT Roadway and Traffic Design Standards Indexes (600 Series), the Standard Specifications for Road and Bridge Construction and the Manuals on Uniform Traffic Control Devices, as minimum criteria.
5. If the Contractor intends to use sub-contractors to perform any work pursuant hereto, these sub-contractors are subject to approval by Town.
6. Contractor shall comply with all applicable Federal, State and local laws, regulations and ordinances. It is the responsibility of the Contractor to procure all necessary permits and licenses for performance of all work hereunder.
7. The Project Manager or Work Crew Supervisor of Contractor must be available by telephone within thirty (30) minutes of initial call in order to be able to reply to the needs and requests of the Town Designee in a most efficient manner Monday through Thursday, 7:00AM to 4:00PM. The Contractor shall confer with the Town's Designee on a daily basis. Work hours in the Town are between 7:00AM and 5:00PM. Upon execution of a contract, the Town will provide the Contractor with after-hours/emergency contact information for the Town's Designee(s).
8. The Contractor shall complete any specific maintenance item, task, or auxiliary service requested by the Town within 24 hours of notification, unless otherwise agreed upon by Town's Designee.
9. Additional services required shall be evaluated by both the Town and the Contractor for the mutual determination of a fair unit cost, to be based upon similar service rendered at similar sites.
10. For items in need of repair, restoration and/or replacement, to include and not be limited to, irrigation systems, pipes and lines, the Contractor shall notify the Town the same work day upon knowledge of such need. The Town may request a proposal for the repair, restoration and/or replacement of the material. The Town reserves the right to seek alternate proposals and to engage the services of others to perform same.
11. The Contractor shall be prohibited from having his vehicles enter the sites specified herein without the prior consent of the Town's Designee. The Contractor shall provide a written staging location plan for the Town's approval prior to commencement of any work.
12. In the event of a natural disaster or other type of emergency which may disrupt the scheduled work or work sites, the Town reserves the right to adjust, modify or suspend services at any and all locations.

TOWN OF SOUTHWEST RANCHES, FLORIDA
TOWN-WIDE IRRIGATION MAINTENANCE SERVICES

13. In the event the Contractor discovers or is made aware of damage, vandalism or theft at a site specified herein, the Contractor shall notify the Town's Designee within 30 minutes of such discovery or awareness.
14. At all times while performing the work subject to RFP, all of the Contractor's personnel shall be required to wear uniforms (e.g. work shirts, etc.) clearly identifying the Contractor's company name, and a Contractor-supplied name and photo identification badge. Working without a shirt and proper identification is not permitted and shall be grounds for removal from Town property.

E. SPECIAL REQUIREMENTS

1. The President/Chief Operating Officer of the Contractor must be available to attend meetings with the Town and/or its designee within 24 hours of notification.
2. For purposes of communicating the Town's needs, a Project Manager or Work Crew Supervisor who can read, write, and speak fluent English is required. The Project Manager or Work Crew Supervisor shall have proven technical and managerial experience in grounds maintenance. The Town reserves the right in its sole discretion to approve or disapprove selection of the Project Manager / Work Crew Supervisor.
3. The Contractor, or an employee of the Contractor approved by the Town, must be on 24 hour call, at all times, for emergency purposes.

F. PROJECT LIMITS

This RFP pertains to maintenance areas including Rights-of-Way and Park properties throughout the Town. Boundaries are Flamingo Road to the East, Sheridan St. to the South, Griffin Road to the north and US 27 (and slightly beyond) to the west. See Maintenance Locations / Zones list for all maintenance areas.

G. DEFINITIONS

Landscape Bed: planted area where shrubs, groundcovers, and /or other plant material and trees are grouped together in a mulched bed.

Maintenance: as defined for this RFP shall include but not be limited to irrigation maintenance and repair services and other miscellaneous work as described herein.

Service Category: Specific type or style of maintenance services indicated by location or zone (some zones are not applicable and therefore not included in this RFP), as follows:

Service Category A: Type or style of maintenance as defined in this RFP in Maintenance Locations/Zones, Zones 1 and 2, Griffin Road East and West.

Service Category D: Type or style of maintenance as defined in this RFP in Maintenance Locations/Zones, Zone 32 through 42, Parks and Other Town Property.

Site: Any individual grounds maintenance location or zone, whole or partial (e.g. "Griffin Road West" or "Sunshine Ranches Equestrian Park. ")

Site Re-inspections: Inspections made by the Town of corrected work necessitated by deficient work.

H. QUANTITY & FREQUENCY OF MAINTENANCE

The area and limits of maintenance have been previously established and are distinguishable in the field. Areas have been inventoried and calculated as to quantity and provided as a courtesy. It shall be the responsibility of the Contractor to verify the quantity of maintenance to be accomplished. Any discrepancies or disagreements concerning quantities shall be mutually resolved in writing prior to beginning work in any area in question. The Contractor shall submit written schedules of maintenance defining frequencies and locations. Contractor's failure to notify the Town in advance of any discrepancies or disagreements shall result in a waiver of any claims by Contractor relating thereto.

TOWN OF SOUTHWEST RANCHES, FLORIDA
TOWN-WIDE IRRIGATION MAINTENANCE SERVICES

I. METHODS OF OPERATION

On the contract commencement date, Contractor shall furnish a complete written proposal of his plan for accomplishing the required work. The Contractor shall exercise the necessary care to preclude any source of litter by his operations.

J. LIMITATION OF OPERATION

No equipment shall be parked overnight in the medians, Rights-of-Way or on Town Property without the Town's prior written consent.

K. ADDITIONS OR DELETIONS OF MAINTENANCE AREA:

At the Town's discretion, it may add new maintenance areas, reduce the frequency of service, or discontinue service by Contractor or request the resumption of service to a previously terminated area at any given time during the life of any contract award. Evaluation of costs for areas that are to be added or deleted shall be calculated based upon unit prices in the Proposal Forms herein. Upon the Town's written request to the Contractor to add a new maintenance area to the contract or resume service to a previously terminated maintenance area, Contractor shall commence maintenance to said area within ten (10) days. Service to locations deleted by the Town for durations less than the remaining life of the contract may be resumed at any time for the originally proposed contract value.

At the Town's discretion, it may delete maintenance areas or the frequency of maintenance from the contract at any given time during the life of the contract, for the life of the contract, or lesser durations. The Town shall give the Contractor ten (10) calendar day's written notice prior to the deletion of a maintenance area for any given period of time. Deleted areas, if less than the entire maintenance area, shall be evaluated using unit prices outlined herein.

L. DAMAGE BY CONTRACTOR

Any damage to the road, facilities, sewers, utilities, irrigation systems, neighboring or adjacent properties or vegetation caused by the Contractor shall be repaired at the expense of the Contractor to the satisfaction of the Town. Failure to restore said damages within three (3) working days following written notification shall result in a deduction from Contractor's next invoice of the Town's expenses for labor, material, services or equipment, including all related Administrative costs incurred by the Town to restore the property to its original condition. Said notification shall be by letter, fax or email.

M. CONTRACTOR'S PERSONNEL

Contractor shall employ personnel competent to perform the work specified herein. The Town reserves the right to request the removal of a Contractor's employee from performing maintenance upon the Town's property where such employee's performance or actions are detrimental to the Town. Contractor shall immediately remove any employee engaged in conduct involving drugs, alcohol consumption or use or possession of firearms/weapons on Town premises. See Drug-Free Workplace Certification Form herein.

N. CONTRACTOR'S VEHICLES

Contractor's vehicles shall be in good repair, free from leaking fluids, properly registered, of uniform color and shall bear the company name on each side in not less than 1-½ inch letters. In addition, vehicles shall bear a magnetic sign on each side stating "Contractor for Southwest Ranches Public Works" when performing work hereunder.

O. QUALITY

The quality and acceptance of workmanship will be determined during site inspections by the Town. Areas that are determined to be unacceptable shall be addressed by the Contractor in accordance with Article 22 above. For each re-inspection required, the Town shall have the discretion to deduct a flat fee of five hundred (\$500) dollars per site requiring re-inspection.

TOWN OF SOUTHWEST RANCHES, FLORIDA
TOWN-WIDE IRRIGATION MAINTENANCE SERVICES

P. IRRIGATION

1. Prior to the commencement of the maintenance program, the Contractor shall have thirty (30) days from the start of the contract to inspect the irrigation systems and report existing damage or incorrect operation and coverage to the Town. After this initial inspection report, the Contractor shall be responsible for the integrity of the systems and repairs as referenced in item P.3, below.
2. The Contractor shall be responsible for the operation and maintenance of the automatic irrigation systems and for setting and adjusting the time clocks and water sensor devices to ensure proper watering of all plant material and turf in the landscape. The Contractor shall notify the Town's Designee of any sprinkler system malfunctions within 24 hours of the Contractor's observation of said malfunction(s).
3. The Contractor shall be responsible for the labor and supervision to make minor irrigation repairs to the risers, sprinkler heads and any lines up to and including two (2) inches in diameter as required to keep the systems operating. Major repairs to main lines, pumps and intake piping and any incidental items shall be reimbursed by the Town. Reimbursable repair work shall require authorization by the Town's Designee prior to commencement.
4. Time clocks shall be checked at least once (1) per week or as may otherwise be required. The Contractor shall, at least once (1) per month, fully operate all irrigation zones and replace, repair or clean all irrigation heads, lines, valves, valve boxes and controllers as needed. Any equipment damaged by the Contractor's operation shall be replaced with the same equipment and by the same manufacturer as originally installed unless otherwise approved by the Town's Designee.
5. The irrigation shall be capable of providing 1½ inch of water to all turf and shrub beds each week or as often as required to provide for a uniform lush green landscape appearance. The systems shall be adjusted by the Contractor during the various seasons. The Contractor shall be required to make all repairs within a minimum twenty-four (24) hour time period or sooner as directed by the Town's Designee. Any form of damage to the irrigation systems must be reported to the Town's Designee in writing within 24 hours of discovery.
6. Irrigate as necessary during periods of little or no rainfall using the automatic irrigation systems and any supplemental watering necessary to apply the proper amount of water to keep the plant material in optimum health. Contractor is responsible for compliance with any water restrictions imposed by any Local, County or State agencies.
7. The Contractor shall provide to the Town's Designee written irrigation schedules and written monthly reports on the function of the irrigation systems, itemizing all authorized repairs performed. The Contractor's monthly invoice shall itemize all components replaced by the Contractor in accordance with unit prices set forth in the Contractor's proposal. The Contractor shall be responsible for controlling the amount of water used for irrigation and any damage that results from over-watering or insufficient watering shall be the responsibility of the Contractor as described in Section O. QUALITY.

[INTENTIONALLY LEFT BLANK]

TOWN OF SOUTHWEST RANCHES, FLORIDA
TOWN-WIDE IRRIGATION MAINTENANCE SERVICES

SERVICE CATEGORIES / MAINTENANCE LOCATIONS / ZONES

SERVICE CATEGORY A:

IRRIGATION MAINTENANCE - ROADS / MEDIANS/ SWALES - GRIFFIN ROAD EAST

Zone 1. GRIFFIN ROAD EAST

ROW: Flamingo Rd. to SW 148 Ave.

b.) Medians – All

c.) 3 Retention Ponds

d.) South swale – All from edge of pavement to property line

Zone 2. GRIFFIN ROAD WEST

ROW: west of Dykes Rd. to east of SW 188 Ave.:

a.) Medians – All

b.) South swale – All

SERVICE CATEGORY D:

IRRIGATION MAINTENANCE - PARKS AND OTHER TOWN PROPERTY

Zone 33. Sunshine Ranches Equestrian Park – 20 acres

Zone 38. Town Hall – 2 acres

~~Zone 39. Public Safety Facility – <1 acre~~

~~Zone 41. Country Estates Park – 16 acres~~

MAINTENANCE FREQUENCIES*

Location / Zone	Acres	Frequency	Jan	Feb	Mar	Apr	May	June	July	Aug	Sep	Oct	Nov	Dec
Irrigation wet test and report	N/A	12	1	1	1	1	1	1	1	1	1	1	1	1

*All counts/frequencies are approximate. The Town reserves the right to add or delete the quantity/frequency of service.

[INTENTIONALLY LEFT BLANK]

TOWN OF SOUTHWEST RANCHES, FLORIDA
TOWN-WIDE IRRIGATION MAINTENANCE SERVICES

PROPOSAL FORMS

MAINTENANCE PROPOSAL: PRICE LIST BY ZONE / SERVICE CATEGORY
(BASE PROPOSAL):

IRRIGATION MAINTENANCE – ROADS

Service Category	Location / Zone #	Location / Zone Name	Unit Price per service	Annual Price – (Frequencies as per "Maintenance Frequencies" sheet)
A	1	GRIFFIN ROAD EAST ROW: Flamingo Rd. to SW 148 Ave. a.) Medians – All b.) 3 Retention Ponds c.) South swale – All from edge of pavement to property line	\$	\$
A	2	GRIFFIN ROAD WEST ROW: west of Dykes Rd. to east of SW 188 Ave.: c.) Medians – All d.) South swale – All	\$	\$
SUBTOTAL IRRIGATION MAINTENANCE – ROADS			\$	

MAINTENANCE PROPOSAL: PRICE LIST BY ZONE / SERVICE CATEGORY
(BASE PROPOSAL):

IRRIGATION MAINTENANCE - PARKS AND OTHER FACILITIES

Service Category	Location / Zone #	Location Name	Unit Price per service	Annual Price – (Frequencies as per "Maintenance Frequencies" sheets)
D	33	Sunshine Ranches Equestrian Park – 20 acres	\$	\$
D	38	Town Hall – <2 acres	\$	\$
SUBTOTAL IRRIGATION MAINTENANCE - PARKS AND OTHER FACILITIES			\$	

GRAND TOTAL – IRRIGATION MAINTENANCE PROPOSAL: PRICE LIST BY ZONE (BASE PROPOSAL):

\$

*All counts/frequencies are approximate. The Town reserves the right to add or delete the quantity/frequency of service.

PROPOSER'S SIGNATURE: _____

COMPANY NAME: _____

TOWN OF SOUTHWEST RANCHES, FLORIDA
TOWN-WIDE IRRIGATION MAINTENANCE SERVICES

MAINTENANCE PROPOSAL: PRICE LIST BY SERVICE (AUXILIARY SERVICES)			
Item No.	Services	Unit	Unit Price
1	Irrigation Supervisor	Per hour 8:00 a.m. - 4:30 p.m., Mon-Fri =	\$
		Per hour for all other times =	\$
2	Irrigation Technician	Per hour 8:00 a.m. - 4:30 p.m., Mon-Fri =	\$
		Per hour for all other times =	\$
3	Irrigation Laborer	Per hour 8:00 a.m. - 4:30 p.m., Mon-Fri =	\$
		Per hour for all other times =	\$

IRRIGATION SYSTEM COMPONENTS (FURNISH AND INSTALL):

Item No.	Service	Unit	Unit Price
4	Rainbird 6" Pop UP	Each	\$
5	Corresponding Rainbird 6" nozzles as per plans/specs	Each	\$
6	Rainbird 12" Pop UP	Each	\$
7	Corresponding Rainbird 12" nozzles as per plans/specs	Each	\$
8	Rainbird 1800 series-- (06 -12)	Each	\$
9	Corresponding 1800 series nozzles as per plans/specs	Each	\$
10	Rainbird 5000 series – Rotor heads	Each	\$
11	Corresponding 5000 series nozzles as per plans/specs	Each	\$
12	Rainbird 7005 series – Rotor heads	Each	\$
13	Corresponding 7005 series nozzles as per plans/specs	Each	\$
14	Rainbird 8005 series – Rotor heads	Each	\$
15	Corresponding 8005 series nozzles as per plans/specs	Each	\$
16	Rainbird Talon series – Rotor heads	Each	\$
17	Corresponding Talon series nozzles as per plans/specs	Each	\$
18	Ell	Each	\$
19	Funny pipe	Per Foot	\$
20	NDS 10" Round valve box	Each	\$
21	NDS 12" X 17" Rectangular valve box	Each	\$
22	Amtech 12" X 18" Rectangular valve box	Each	\$
23	Rainbird 300 BPE Electric Remote Control Valves	Each	\$
24	Rainbird PGA series 2" Electric Remote Control Valves	Each	\$
25	Rainbird 5LRC 5 ½" quick coupling Valves	Each	\$
26	Rainbird PEBPRS-D "Control Valve"	Each	\$
27	Rainbird 200 series Electric Remote Control Valve	Each	\$
28	Rainbird PRS Dial pressure regulating device	Each	\$

*All counts/frequencies are approximate. The Town reserves the right to add or delete the quantity/frequency of service.

PROPOSER'S SIGNATURE: _____

COMPANY NAME: _____

TOWN OF SOUTHWEST RANCHES, FLORIDA
TOWN-WIDE IRRIGATION MAINTENANCE SERVICES

The Proposer offers the preceding completed Proposal Forms for providing all labor, services, materials equipment, etc., to perform Town-Wide Irrigation Maintenance Services in accordance with the specifications herein.

PROPOSER'S SIGNATURE: _____

PROPOSER'S NAME: _____

COMPANY NAME: _____

EMAIL ADDRESS: _____

[INTENTIONALLY LEFT BLANK]

TOWN OF SOUTHWEST RANCHES, FLORIDA
TOWN-WIDE IRRIGATION MAINTENANCE SERVICES

OTHER REQUIRED SIGNATURES AND SUBMITTALS

Proposers are required to complete, provide and/or execute the documents in this section. Response to the Required Signatures and Submittals will be utilized as part of the Town's overall proposal evaluation and contract selection procedure.

PROPOSAL SECURITY

Simultaneous with the delivery of an executed Proposal to the Town, Proposer shall furnish to the Town a Proposal Security in an amount equal to five percent (5%) of the total annual amount proposed for all services. The Proposal Security shall be issued in the form of a bond issued by a Surety authorized to transact business in the State of Florida, having an authorized agent in the State of Florida, or in the form of cash, cashier's check payable to the Town of Southwest Ranches, Florida and drawn on a Florida Bank, or in the form of an irrevocable letter of credit or other alternative form of security acceptable to the Town. Failure to supply Proposal Security with the Proposal at the time of Proposal opening shall automatically disqualify the Proposer as non-responsive.

CONTRACTOR QUALIFICATIONS

Evidence that the Proposer holds appropriate licenses to perform the work subject of this Proposal, and as required by Florida Statutes and Local law, must be submitted along with Proposal. Proposers must also have insurance and bonding capacity sufficient to satisfy the requirements of this solicitation, as set forth herein.

PROFESSIONAL ORGANIZATIONS

1. In accordance with the evaluation factors set forth at section 10.3, preference shall be given to Contractors' proposals evidencing the following professional certifications and memberships in good standing:
 - A. Certified Irrigation Contractor (CIC), issued by the Irrigation Association
 - B. Certificate of Training, Best Management Practices, Florida Green Industries, issued by the Florida Department of Environmental Protection
 - C. Membership in Florida Irrigation Society
 - D. Membership in Irrigation Association

CONFLICTS OF INTEREST

The award of any contract hereunder is subject to the provisions of Chapter 112, Florida State Statutes. Proposers must disclose with their Proposals, the name of any officer, director, partner, associate, agent, Advisory Board member or client/customer who is also an officer, former officer, or employee of the Town of Southwest Ranches or its agencies.

TOWN OF SOUTHWEST RANCHES, FLORIDA
TOWN-WIDE IRRIGATION MAINTENANCE SERVICES

DRUG FREE WORKPLACE

Proposers must certify that they will provide a drug-free workplace. Preference shall be given to businesses with drug-free workplace programs in accordance with the Town's Procurement Code. In order to have a drug-free workplace program, a business shall:

- 1 Publish a statement notifying employees that the unlawful manufacture, distribution, dispensing, possession, or use of a controlled substance is prohibited in the workplace and specifying the actions that will be taken against employees for violations of such prohibition.
- 2 Inform employees about the dangers of drug abuse in the workplace, the business's policy of maintaining a drug-free workplace, any available drug counseling, rehabilitation, and employee assistance programs, and the penalties that may be imposed upon employees for drug abuse violations.
- 3 Give each employee engaged in providing the commodities or contractual services that are under Proposal a copy of the statement specified in subsection (1).
- 4 In the statement specified in subsection (1), notify the employees that, as a condition of working on the commodities or contractual services that are under Proposal, the employee will abide by the terms of the statement and will notify the employer of any conviction of, or plea of guilty or nolo contendere to, any violation of chapter 893 or of any controlled substance law of the United States or any state, for a violation occurring in the workplace no later than five (5) days after such conviction.
- 5 Impose a sanction on, or require the satisfactory participation in a drug abuse assistance or rehabilitation program, if such is available in the employee's community, by any employee who is so convicted.
- 6 Make a good faith effort to continue to maintain a drug-free workplace through implementation of this section.

As the person authorized to sign the statement, I certify that this firm complies fully with the above requirements.

PROPOSER'S SIGNATURE: _____

COMPANY NAME: _____

TOWN OF SOUTHWEST RANCHES, FLORIDA
TOWN-WIDE IRRIGATION MAINTENANCE SERVICES

PUBLIC ENTITY CRIMES

Pursuant to the provisions of paragraph (2) (a) of Section 287.133, Florida State Statutes - "A person or affiliate who has been placed on the convicted vendor list following a conviction for a public entity crime may not submit a Proposal on a contract to provide any goods or services to a public entity, may not submit a Proposal on a contract with a public entity for the construction or repair of a public building or public work, may not submit Proposals on leases of real property to a public entity, may not be awarded to perform work as a contractor, supplier, subcontractor, or consultant under a contract with any public entity, and may not transact business with any public entity in excess of the threshold amount Category Two of Sec. 287.017, F.S. for thirty six (36) months from the date of being placed on the convicted vendor list".

[INTENTIONALLY LEFT BLANK]

TOWN OF SOUTHWEST RANCHES, FLORIDA
TOWN-WIDE IRRIGATION MAINTENANCE SERVICES

SWORN STATEMENT PURSUANT TO SECTION 287.133(3)(a), FLORIDA STATUTES, ON PUBLIC ENTITY CRIMES

THIS FORM MUST BE SIGNED AND SWORN TO IN THE PRESENCE OF A NOTARY PUBLIC OR OTHER OFFICIAL AUTHORIZED TO ADMINISTER OATHS.

1. This sworn statement is submitted to _____

By _____ for _____

whose business address is _____

and (if applicable) its Federal Employer Identification Number (FEIN) is _____

(IF the entity has no FEIN, include the Social Security Number of the individual signing this sworn statement: _____)

2. I understand that a "public entity crime" as defined in Paragraph 287.133(1)(g), Florida Statutes, means a violation of any state or federal law by a person with respect to and directly related to the transaction of business with any public entity or with an agency or political subdivision of any other state or with the United States, including, but not limited to, any Proposal or contract for goods or services to be provided to any public entity or an agency or political subdivision of any other state of the United States and involving antitrust, fraud, theft, bribery, collusion, racketeering, conspiracy, or material misrepresentation.
3. I understand that "convicted" or "conviction" as defined in Para. 287.133(1)(b), Florida Statutes, means a finding of guilt or a conviction of a public entity crime, with or without an adjudication of guilt, in any federal or state trial court of record relating to charges brought by indictment or information after July 1, 1989, as a result of a jury verdict, non-jury trial, or entry of a plea of guilty or nolo contendere.
4. I understand that an "affiliate" as defined in Para. 287.133(1)(a), Florida Statutes, means:
 - (i). A predecessor or successor of a person convicted of a public entity crime; or
 - (ii). Any entity under the control of any natural person who is active in the management of the entity and who has been convicted of a public entity crime. The term "affiliate" includes those officers, directors, executives, partners, shareholders, employees, members, and agents who are active in the management of an affiliate. The ownership by one person of shares constituting a controlling interest in another person, or a pooling of equipment or income among persons when not for fair market value under an arm's length agreement, shall be a prime facie case that one person controls another person. A person who knowingly enters into a joint venture with person who has been convicted of a public entity crime in Florida during the preceding thirty six (36) months shall be considered an affiliate.
5. I understand that a "person" as defined in Para. 287.133(1)(e), Florida Statutes, means any natural person or entity organized under the laws of any state or of the United States with the legal power to enter into a binding contract and which Proposals or applies to Proposal on contracts for the provision of goods or services let by a public entity, or which otherwise transacts or applies to transact business with a public entity. The term "persons" includes those officers, directors, executives, partners, shareholders, employees, members, and agents who are active in management of any entity.

TOWN OF SOUTHWEST RANCHES, FLORIDA
TOWN-WIDE IRRIGATION MAINTENANCE SERVICES

6. Based on information and belief, the statement which I have marked below is true in relation to the entity submitting this sworn statement. (Indicate which statement applies.)

_____ Neither the entity submitting this sworn statement, nor any of its officers, directors, executives, partners, shareholders, employees, members, or agents who are active in the management of the entity, nor any affiliate of the entity has been charged with and convicted of a public entity crime subsequent to July 1, 1989.

_____ The entity submitting this sworn statement, or one or more of its officers, directors, executives, partners, shareholders, employees, members, or agents who are active in the management of the entity or an affiliate of the entity has been charged with and convicted of a public entity crime subsequent to July 1, 1989.

_____ The entity submitting this sworn statement, or one or more of its officers, directors, executives, partners, shareholders, employees, members, or agents who are active in the management of the entity or an affiliate of the entity has been charged with and convicted of a public entity crime subsequent to July 1, 1989.

However, there has been a subsequent proceeding before a Hearing Officer of the State of Florida, Division of Administrative Hearings and the Final Order entered by the Hearing Officer of the State of Florida, Division of Administrative Hearings and the Final Order entered by the Hearing Officer determined that it was not in the public interest to place the entity submitting this sworn statement on the convicted vendor list. (Attach a copy of the final order.)

I UNDERSTAND THAT THE SUBMISSION OF THIS FORM TO THE CONTRACTING OFFICER FOR THE PUBLIC ENTITY IDENTIFIED IN PARAGRAPH 1 (ONE) ABOVE IS FOR THAT PUBLIC ENTITY ONLY AND, THAT THIS FORM IS VALID THROUGH DECEMBER 31 OF THE CALENDAR YEAR IN WHICH IT IS FILED. I ALSO UNDERSTAND THAT I AM REQUIRED TO INFORM THE PUBLIC ENTITY PRIOR TO ENTERING INTO A CONTRACT IN EXCESS OF THE THRESHOLD AMOUNT PROVIDED IN SECTION 287.017, FLORIDA STATUTES, FOR CATEGORY TWO OF ANY, CHANGE IN THE INFORMATION CONTAINED IN THIS FORM.

By: _____

(Printed Name)

(Title)

Sworn to and subscribed before me this _____ day of _____, 20_____

Personally known _____ Or Produced Identification _____
(Type of Identification)

Notary Public - State of _____ My Commission Expires _____

(Printed, typed, or stamped commissioned name of notary public)

PROPOSER'S SIGNATURE: _____

COMPANY NAME: _____

TOWN OF SOUTHWEST RANCHES, FLORIDA
TOWN-WIDE IRRIGATION MAINTENANCE SERVICES

NON-COLLUSIVE AFFIDAVIT

State of _____)
County of _____) ss.

_____ being first duly sworn deposes and says that:

- 1 He/She is the _____
(Owner, Partner, Officer, Representative or Agent) of
_____ the Proposer that has submitted the
attached Proposal;
- 2 He/She is fully informed respecting the preparation and contents of the attached Proposal and of
all pertinent circumstances respecting such Proposal;
- 3 Such Proposal is genuine and is not a collusive or sham Proposal;
- 4 Neither the said Proposer nor any of its officers, partners, owners, agents, representatives,
employees or parties in interest, including this affiant, have in any way colluded, conspired,
connived or agreed, directly or indirectly, with any other Proposer, firm, or person to submit a
collusive or sham Proposal in connection with the Work for which the attached Proposal has been
submitted; or to refrain from proposing in connection with such Work; or have in any manner,
directly or indirectly, sought by agreement or collusion, or communication, or conference with any
Proposer, firm, or person to fix any overhead, profit, or cost elements of the Proposal or of any
other Proposer, or to fix any overhead, profit, or cost elements of the Proposal price or the Proposal
price of any other Proposer, or to secure through any collusion, conspiracy, connivance, or unlawful
agreement any advantage against (Recipient), or any person interested in the proposed Work;
- 5 The price or prices quoted in the attached Proposal are fair and proper and are not tainted by any
collusion, conspiracy, connivance, or unlawful agreement on the part of the Proposer or any other
of its agents, representatives, owners, employees or parties in interest, including this affiant.

By: _____

(Printed Name)

(Title)

Sworn to and subscribed before me this _____ day of _____, 20____
Personally known _____
Or Produced Identification _____
(Type of Identification)
Notary Public - State of _____

My Commission Expires _____
(Printed, typed, or stamped commissioned name of notary public)

PROPOSER'S SIGNATURE: _____

COMPANY NAME: _____

TOWN OF SOUTHWEST RANCHES, FLORIDA
TOWN-WIDE IRRIGATION MAINTENANCE SERVICES

CERTIFICATE OF AUTHORITY (If Individual / Sole Proprietor)

State of _____)
County of _____) ss.

I HEREBY CERTIFY that _____, as Principal or Owner of
_____, is hereby authorized to execute the Proposal dated, _____ 20
(Company name)
to the Town of Southwest Ranches and his execution thereof, attested by the undersigned, shall be the
official act and deed of _____.
(Company name)

IN WITNESS WHEREOF, I have hereunto set my hand this _____ day of _____, 20

Secretary:
(SEAL)

PROPOSER'S SIGNATURE: _____

COMPANY NAME: _____

TOWN OF SOUTHWEST RANCHES, FLORIDA
TOWN-WIDE IRRIGATION MAINTENANCE SERVICES

CERTIFICATE OF AUTHORITY (If Corporation or Limited Liability Company)

State of _____)
County of _____) ss.

I HEREBY CERTIFY that a meeting of the Board of Directors of a corporation or authorized representatives of a Limited Liability Company existing under the laws of the State of _____, held on _____, 20_____, the following resolution was duly passed and adopted:
"RESOLVED, that _____, as President of the Corporation or authorized representative of a Limited Liability Company, be and is hereby authorized to execute the Proposal dated, 20_____, to the Town of Southwest Ranches and this corporation or Limited Liability Company and his execution thereof, attested by the Secretary of the Corporation or Limited Liability Company, and with the Corporate Seal affixed, shall be the official act and deed of this Corporation or Limited Liability Company."

I further certify that said resolution is now in full force and effect.

IN WITNESS WHEREOF, I have hereunto set my hand and affixed the official seal of the corporation or Limited Liability Company this _____ day of _____, 20 _____.

Secretary:

(SEAL)

PROPOSER'S SIGNATURE: _____

COMPANY NAME: _____

TOWN OF SOUTHWEST RANCHES, FLORIDA
TOWN-WIDE IRRIGATION MAINTENANCE SERVICES

CERTIFICATE OF AUTHORITY (If Partnership)

State of _____)
County of _____) ss.

I HEREBY CERTIFY that a meeting of the Partners of the _____

_____ a partnership existing under the laws of the State of _____, held on _____, 20____, the following resolution was duly passed and adopted:

"RESOLVED, that, _____, as _____ of the Partnership, be and is hereby authorized to execute the Proposal dated, _____ 20____, to the Town of Southwest Ranches and this partnership and that his execution thereof, attested by shall be the official act and deed of this Partnership."

I further certify that said resolution is now in full force and effect.

IN WITNESS WHEREOF, I have hereunto set my hand this____, day of _____, 20_____.

Secretary:

(SEAL)

PROPOSER'S SIGNATURE: _____

COMPANY NAME: _____

TOWN OF SOUTHWEST RANCHES, FLORIDA
TOWN-WIDE IRRIGATION MAINTENANCE SERVICES

CERTIFICATE OF AUTHORITY (If Joint Venture)

State of _____)
County of _____) ss.

I HEREBY CERTIFY that a meeting of the Principals of the _____

_____ a corporation existing under the laws of the State of _____, held on _____, 20 _____, the following resolution was duly passed and adopted:

"RESOLVED, that, _____ as _____ of the Joint Venture be and is hereby authorized to execute the Proposal dated, _____ 20____, to the Town of Southwest Ranches official act and deed of this Joint Venture."

I further certify that said resolution is now in full force and effect.

IN WITNESS WHEREOF, I have hereunto set my hand this ____, day of _____, 20__.

Secretary:

(SEAL)

PROPOSER'S SIGNATURE: _____

COMPANY NAME: _____

TOWN OF SOUTHWEST RANCHES, FLORIDA
TOWN-WIDE IRRIGATION MAINTENANCE SERVICES

PROPOSER QUALIFICATION

List Number of Irrigation Maintenance Contracts in excess of Fifty Thousand Dollars (\$50,000) per year in the past five (5) years.

Project Name: _____

Client Name: _____

Address: _____

Contact Person: _____

Contact Person Tel. No.: _____

Project Name: _____

Client Name: _____

Address: _____

Contact Person: _____

Contact Person Tel. No.: _____

Project Name: _____

Client Name: _____

Address: _____

Contact Person: _____

Contact Person Tel. No.: _____

Project Name: _____

Client Name: _____

Address: _____

Contact Person: _____

Contact Person Tel. No.: _____

Project Name: _____

Client Name: _____

Address: _____

Contact Person: _____

Contact Person Tel. No.: _____

PROPOSER'S SIGNATURE: _____

COMPANY NAME: _____

TOWN OF SOUTHWEST RANCHES, FLORIDA
TOWN-WIDE IRRIGATION MAINTENANCE SERVICES

GOVERNMENTAL CONTACT INFORMATION

List any Governmental or Quasi-governmental Agencies for which the Proposer has done business within the past five (5) years.

Name of Agency: _____

Address: _____

Phone No.: _____ Contact Person: _____

Name of Agency: _____

Address: _____

Phone No.: _____ Contact Person: _____

Name of Agency: _____

Address: _____

Phone No.: _____ Contact Person: _____

Name of Agency: _____

Address: _____

Phone No.: _____ Contact Person: _____

Name of Agency: _____

Address: _____

Phone No.: _____ Contact Person: _____

Name of Agency: _____

Address: _____

Phone No.: _____ Contact Person: _____

Name of Agency: _____

Address: _____

Phone No.: _____ Contact Person: _____

Name of Agency: _____

Address: _____

Phone No.: _____ Contact Person: _____

PROPOSER'S SIGNATURE: _____

COMPANY NAME: _____

TOWN OF SOUTHWEST RANCHES, FLORIDA
TOWN-WIDE IRRIGATION MAINTENANCE SERVICES

SUBCONTRACTORS

List all Subcontractors to be used on this project if the Proposer is awarded a contract.

**CLASSIFICATION
OF WORK**

**NAME, ADDRESS, PHONE
OF SUBCONTRACTORS**

PROPOSER'S SIGNATURE: _____

COMPANY NAME: _____

TOWN OF SOUTHWEST RANCHES, FLORIDA
TOWN-WIDE IRRIGATION MAINTENANCE SERVICES

PROPOSED MANAGEMENT PLAN

Provide a written description of proposed plan to accomplish work, including structure of provider, organizational chart and auxiliary services offered, crews, personnel and equipment to be dedicated to this project, if the Proposer is awarded a Contract. (Use additional sheets if necessary.)

PROPOSER'S SIGNATURE: _____
COMPANY NAME: _____

TOWN OF SOUTHWEST RANCHES, FLORIDA
TOWN-WIDE IRRIGATION MAINTENANCE SERVICES

PROPOSER DISCLOSURE OF LITIGATION HISTORY

The Proposer's response to this questionnaire will be utilized as part of the Town's overall Proposal Evaluation and Contractor selection.

List all cases where Proposer has been a party to litigation or arbitration (or other binding dispute resolution procedure), whether plaintiff or defendant (petitioner or respondent), within the past five (5) years including case name, case number, jurisdiction, whether case has been resolved or is still pending, and a brief description of the nature of the case.

Case Name: _____

Case Number: _____

Jurisdiction: _____

Plaintiff: _____

Defendant: _____

Case Status: Resolved _____ Pending _____

Brief description of nature of case: _____

Case Name: _____

Case Number: _____

Jurisdiction: _____

Plaintiff: _____

Defendant: _____

Case Status: Resolved _____ Pending _____

Brief description of nature of case: _____

Case Name: _____

Case Number: _____

Jurisdiction: _____

Plaintiff: _____

Defendant: _____

Case Status: Resolved _____ Pending _____

Brief description of nature of case: _____

PROPOSER'S SIGNATURE: _____

COMPANY NAME: _____

TOWN OF SOUTHWEST RANCHES, FLORIDA
TOWN-WIDE IRRIGATION MAINTENANCE SERVICES

STATEMENT OF NO RESPONSE

Recipients of this solicitation may elect not to respond. The Town is interested in learning the reason(s) for non-response. If you elect not to respond with an offer to this solicitation, the Town requests that the reason(s) be indicated below and this form returned to:

Juanita Romance, Procurements and Special Projects
Town of Southwest Ranches
13400 Griffin Road
Southwest Ranches, FL 33330
or
Email: jromance@southwestranches.org

REASONS

1. _____ Do not Offer this product/service or equivalent.
2. _____ Schedule would not permit.
3. _____ Insufficient time to respond to solicitation.
4. _____ Unable to meet specifications / scope of work.
5. _____ Specifications "too tight" (i.e. geared to specific brand or manufacturer).
6. _____ Specifications not clear.
7. _____ Unable to meet bond and / or insurance requirements.
8. _____ Solicitation addressed incorrectly, delayed in forwarding of mail.
9. _____ Other (Explanation provided below or by separate attachment).

Explanation: _____

The Town may delete the names of those persons or businesses who fail to respond to three (3) solicitations, who fail to return this Statement, or as requested.

Desire to receive future Town solicitations? Yes No

COMPANY: _____

NAME: _____ TITLE: _____

ADDRESS: _____

TELEPHONE: (____) _____ DATE: _____

TOWN OF SOUTHWEST RANCHES, FLORIDA
TOWN-WIDE IRRIGATION MAINTENANCE SERVICES

ATTACHMENTS AND EXHIBITS:

ATTACHMENT "A" – AGREEMENT FORM – TO BE EXECUTED AFTER AWARD OF CONTRACT

EXHIBITS - GRIFFIN ROAD EAST AND WEST IRRIGATION PLANS

THIS IS AN AGREEMENT (“Agreement”) made and entered into on this ____ day of _____ 201_ by and between the Town of Southwest Ranches, a Municipal Corporation of the State of Florida, (hereinafter referred to as “Town”) and _____ (hereinafter referred to as “Contractor”).

WHEREAS, the Town desires to select a contractor for the purpose of **Town-Wide Irrigation Maintenance Services (“Project”)**; and

WHEREAS, the Town advertised a Request for Proposals, RFP No. 14-012 on September 17, 2014 (“RFP”); and

WHEREAS, __ proposals were received by the TOWN on November 20, 2014; and

WHEREAS, the Town has adopted Resolution No. 201_ - ____ at a public meeting of the Town Council approving the recommended award and has selected _____ for award of the Project; and

WHEREAS, the proposal submitted to the Town by Contractor is attached to this Agreement as Exhibit “A-1” and made a part hereof.

NOW THEREFORE, in consideration of the foregoing premises and the mutual terms and conditions herein, the Town and Contractor hereby agree as follows:

1. CONTRACT DOCUMENTS/SCOPE OF WORK: The Contract Documents consist of the following documents: Request for Proposals #14-012 (attached herein as Composite Exhibit “B,” hereinafter interchangeably referred to as the “Scope of Services,” “Services,” or “Work” unless otherwise specified), which is incorporated herein by reference and shall be completely integrated and construed as being a specific part of this Agreement, Contractor’s Proposal (Exhibit “A-1”), this Agreement and any written modifications hereto. In the case of a conflict in the Contract Documents, those requiring the more stringent performance by Contractor shall govern. The Contractor shall provide Town-wide Irrigation Maintenance Services for the term of this Agreement, and any approved extensions thereto (as set forth in Section 24 of the RFP). The Work includes but is not limited to the following: furnish all of the labor, materials, equipment services and incidentals necessary to perform all of the Work described and detailed in, or reasonably inferable from, the Contract Documents. Refer also to SCOPE OF SERVICES / SPECIFICATIONS, Sections A-P of the RFP. All Work rendered pursuant to this Agreement by Contractor shall be performed in strict accordance with the applicable standard of care for persons or entities performing similar work in Broward County, Florida. Contractor shall perform the Work in strict accordance with the requirements of this Agreement, all of the other Contract Documents, good construction and/or best management practices for this type of Work performed in Broward County, Florida and all applicable codes, ordinances, rules, laws and regulations governing the Work, including, but not limited to, the Florida Building Code, along with Broward County Amendments to it.

2. LICENSING/PERMITS: Contractor represents that it will maintain at all times during the progress of any Work and any warranty period, all licenses, certificates of competency or other documents required by the Scope of Services evidencing compliance with licensure requirements necessary to practice his profession as required by Florida law, Broward County, and the Town’s Code.

3. INSURANCE: Contractor shall procure and maintain at all times during the performance of this Agreement, including any approved extensions thereof, all insurance coverages required by, and in the manner specified in, Section 9 of the RFP.

4. INDEMNIFICATION: Contractor's indemnification obligations are set forth in Section 16 of the RFP. Contractor further agrees that in claims against any person indemnified hereunder by an employee of Contractor, a subcontractor, anyone directly or indirectly employed by them or anyone for whose acts they may be liable, the indemnification obligations hereunder shall not be limited by a limitation on amount or type or amount of damages, compensation or benefits payable under worker's compensation acts, disability benefits acts, or other employee benefits acts. The Town shall not in any way be answerable or accountable for any violations of applicable laws or for any injury, loss or damage arising from the negligent or intentional act or omission of Contractor or any one of its employees, contractors or agents.

5. CHANGES TO SCOPE OF WORK: The Town shall not accept any change orders from the Contractor for the Project unless approved in writing by the Town. By executing this Agreement, Contractor specifically acknowledges that Contractor has performed its due diligence and will perform the Work for the prices stated in Contractor's Proposal attached hereto, for the term of this Agreement, and any approved extensions thereof.

6. COMPENSATION & METHOD OF PAYMENT

- .1 The amount of compensation payable by the Town to Contractor shall be based upon the rates and schedules (interchangeably referred to as the "Contract Price" or "Agreement Sum") as set forth in Composite Exhibit "B" which amount shall be accepted by Contractor as full compensation for all such work performed under this Agreement. It is acknowledged and agreed by Contractor that these amounts are the maximum payable and constitute a limitation upon Town's obligation to compensate Contractor for its Services related to this Agreement. This maximum amount, however, does not constitute a limitation of any sort, upon Contractor's obligation to perform all items of work required by or which can be reasonably inferred from the Scope of Services.
- .2 The initial rates and schedules have been adopted by the Town Council as part of the Resolution enacting this Agreement. The Town Council, at its own discretion, may increase the rate by subsequent Resolution.
- .3 Town shall pay Contractor in accordance with the Florida Prompt Payment Act. Additionally, payment may be withheld by the Town Administrator, for failure of Contractor to comply with a term, condition or requirement of this Agreement.
- .4 Town shall not be liable for any cost increases or escalation associated with labor, materials, including but not limited to petroleum, that may arise during the performance of the Work. In the event the cost of the Work exceeds the amounts defined herein as the Agreement Sum, Contractor shall pay such excess from its own funds and Town shall not be required to pay any part of such excess. The only exception shall be any adjustments to the Agreement Sum pursuant to any written Change Order duly executed by Town and Contractor in accordance with the terms and conditions of this Agreement, and with the same formality and of equal dignity associated with the original execution of this Agreement.
- .5 Town and Contractor agree that payment under this Agreement will be subject to (a) the delivery of an appropriate invoice by Contractor to Town, and (b) verification by Town that the Work has been performed in accordance with this Agreement. Upon verification by Town that the invoiced Work has been performed in accordance with this Agreement, Town shall have thirty (30) days thereafter to pay said invoice.

- .6 Notwithstanding any provision of this Agreement to the contrary, the Town Administrator may withhold, in whole or in part, payment to the extent necessary to protect itself from loss on account of inadequate or defective work of Contractor which has not been remedied or resolved in a manner satisfactory to the Town Administrator. The amount withheld shall not be subject to payment of interest by Town.
- .7 Town reserves the right in the event the primary vendor cannot provide an item(s) or service(s) in a timely manner as requested, to seek other sources without violating the intent of the contract.
- .8 In case of default by Contractor, Town may procure the articles or services from other sources and hold Contractor responsible for any excess costs occasioned or incurred thereby.

7. ASSIGNMENT: Refer to Section 19 of the RFP. No assignment of this Agreement or of the Work hereunder by Contractor shall be valid without the express written consent of the Town Administrator, which may be given or withheld, in Town's sole discretion. All Work to be performed pursuant to this Agreement shall be performed by Contractor, and no Work shall be subcontracted to other parties or firms without the written consent and approval of the Town Administrator.

8. WARRANTIES: Contractor warrants to the Town that all materials, supplies, equipment and Work under this Agreement will be of good quality, free from faults and defects and in conformance with the Contract Documents.

9. CONTRACTOR'S RESPONSIBILITY FOR SAFETY AND TO PROTECT WORK: Contractor shall be responsible for initiating, maintaining and supervising all safety precautions and programs in connection with the Work provided pursuant to this Agreement in order to prevent, inter alia, damage, injury or loss to (a) all employees performing the Work and all other persons who may be affected thereby, (b) all the Work and all materials and equipment to be incorporated therein and (c) other property at the site or adjacent thereto. Contractor shall timely provide all notices and comply with all applicable laws, ordinances, rules, regulations and orders of any public authority or other authority with jurisdiction bearing on the safety of persons and property in order to provide protection from damage injury or loss. Contractor shall also take reasonable steps to protect the Work and any adjacent or immediately surrounding property against all loss or damage, and shall promptly repair any damage done from any cause whatsoever. If such loss or damage is caused by Contractor's failure to properly protect or perform the Work or is otherwise caused from Contractor's intentional or negligent actions or omissions, such repairs shall be without cost or expense to the Town. In the event that the loss or damage is caused solely by an employee or agent of the Town and could not reasonably be avoided by Contractor's reasonable efforts to protect the Work or surrounding property, then the Town and Contractor shall negotiate a reasonable cost to repair the damage, and such costs shall be accounted for through the issuance of a change order to this Agreement.

10. DEFECTIVE WORK: Contractor shall promptly correct or remove, at its sole expense, any defective Work and replace it with non-defective Work. Contractor shall pay all direct, indirect, and consequential costs of such removal or correction.

11. DEFAULT/TERMINATION FOR CAUSE: Refer to Section 22 of the RFP.

11.1. In addition, the occurrence of any one or more of the following events will justify Town's termination of Contractor for cause:

- .1 Contractor's performance of defective work or persistent failure to perform the Work in strict

accordance with the Contract Documents (including, but not limited to, failure to supply sufficient skilled workers or suitable materials or equipment);

- .2 Contractor's disregard of Laws or Regulations of any public body having jurisdiction state or federal laws;
 - .3 Violation of Town's policies and procedures, including Contractor's disregard of the authority of the Town, including the Contract Manager;
 - .4 Contractor's violation of any provisions of the Contract Documents;
 - .5 Contractor's Abandonment of the Work;
 - .6 Contractor's insolvency, bankruptcy, or assignment for the benefit of creditors.
- 11.2. If one or more of the events identified in paragraph 11.1 occur, Town may, after giving Contractor thirty (30) days written notice, terminate the services of Contractor.
- 11.3 Where Contractor's services have been so terminated by Owner, the termination will not affect any rights or remedies of the Town against Contractor then existing or which may thereafter accrue. Any retention or payment of moneys due Contractor by Town will not release Contractor from liability.
- 11.4 If, after notice of termination of Contractor's right to proceed, it is found that Contractor was not in default or that sufficient grounds for termination for cause did not exist, the termination shall be deemed automatically converted to one for convenience, and the rights and obligations of the Town and Contractor shall be the same as if the notice of termination were issued pursuant to Section 13 below.

12. TERMINATION FOR CONVENIENCE: Refer to Section 22.2 of the RFP.

12.1. The Agreement may be terminated for convenience in writing by the Town, without cause and without prejudice to any other right or remedy of Town, upon thirty (30) days written notice to Contractor of its intent to terminate and the date on which such termination becomes effective. In such case, Contractor shall be paid (without duplication of any items) for:

- .1 Completed and acceptable work executed in accordance with the Contract Documents prior to the effective date of termination, including fair and reasonable sums for overhead and profit on such Work, provided however, that Contractor must first provide Town with sufficient back-up documentation for such Work;
 - .2 Expenses sustained prior to the effective date of termination in performing services and furnishing labor, materials, or equipment as required by the Contract Documents, plus fair and reasonable sums for overhead and profit on such expenses;
- 12.2 Under no circumstances shall payment include, or Town be liable for, lost or anticipated profit for Work or services not performed, nor for indirect, special or consequential damages of any kind.

13. INTERPRETATION:

13.1. Entire Agreement. This Agreement, including the Contract Documents, constitutes the entire agreement of the parties with respect to the subject matter hereof. No other agreements, oral or written, pertaining to the Work to be performed under this Agreement exist between the parties. This Agreement may be modified only by a written change order signed by both parties.

13.2. Governing Law. This Agreement shall be interpreted and governed in accordance with the laws of the State of Florida.

14. ATTORNEYS' FEES AND COSTS: If any party to this Agreement brings a cause of action against the other party arising from or relating to this Agreement the prevailing party in such proceeding shall be entitled to recover reasonable attorney's fees, experts fees, and court costs (at both the trial and appellate levels).

15. CONTRACTOR'S PERFORMANCE:

15.1 Contractor shall not subcontract any portion of the work required by this Agreement, except with the prior approval of the Town Administrator, which shall be in his sole and absolute discretion. If subcontractors are to be used during the term of this Agreement, a list of such subcontractors shall be provided to the Town Administrator, subject to his approval.

15.2 Contractor agrees to perform its Work in a professional manner and in accordance with all applicable Local, State, County, and Federal laws, rules, ordinances, regulations and codes. Contractor agrees that the Work provided shall be provided by employees that are legally employable in the United States of America, educated, trained, experienced, certified, and licensed in all areas encompassed within their designated duties. Contractor agrees to furnish to TOWN any and all documentation, certifications, authorizations, licenses, permits, or registrations currently required by applicable laws, rules, and regulations. Contractor further certifies that it and its employees will keep all licenses, permits, registrations, authorizations, or certifications required by applicable laws or regulations in full force and effect during the term of this Agreement. Contractor represents that all persons performing the services required under this Agreement have the knowledge and skills, either by training, experience, education, or a combination thereof, to adequately and competently perform the duties, obligations, and services set forth herein in a skillful and respectable manner.

15.3 Failure of Contractor to comply with this paragraph shall constitute a material breach of this Agreement.

16. DISPUTE RESOLUTION: Refer to Section 11 of the RFP.

16.1 To prevent all disputes and litigation, it is agreed by the parties hereto that the Town Administrator or his designee shall decide all questions, claims, difficulties and disputes of whatever nature which may arise relative to the technical interpretation of the Contract Documents and fulfillment of this Agreement as to the character, quality, amount and value of any Work done and materials furnished, or proposed to be done or furnished under or, by reason of, the Contract Documents and such decisions of all claims, questions, difficulties and disputes shall be final and binding, subject to judicial resolution.

- 16.2. During the pendency of any dispute and after a determination thereof, Contractor and Town shall act in good faith to mitigate any potential damages.
- 16.3. In the event the determination of a dispute under this Section 16 is unacceptable to either party hereto, the party objecting to the determination must notify the other party in writing within ten (10) calendar days of receipt of the written determination. The notice must state the basis of the objection and must be accompanied by a statement that any adjustment claimed is the entire adjustment to which the objecting party has reason to believe it is entitled to as a result of the determination. Within sixty (60) calendar days thereafter, the parties shall participate in mediation to address all objections to any determinations hereunder and to attempt to prevent litigation. Neither party shall commence litigation prior to the expiration of the sixty (60) day mediation period. The mediator shall be mutually agreed upon by the parties. Should any objection not be resolved in mediation, the parties retain all their legal rights and remedies provided under State law. **A PARTY SPECIFICALLY WAIVES ALL OF ITS RIGHTS, INCLUDING BUT NOT LIMITED TO CLAIMS FOR PRICE ADJUSTMENTS, PROVIDED IN THE CONTRACT DOCUMENTS, INCLUDING ITS RIGHTS AND REMEDIES UNDER STATE LAW, IF SAID PARTY FAILS TO COMPLY IN STRICT ACCORDANCE WITH THE REQUIREMENTS OF THIS SECTION. Contractor and Town hereby waive any rights to a trial by jury.**

17. AUDIT OF PROJECT RECORDS: Town shall have the right to audit the books, records and accounts of Contractor that are related to this Agreement. Contractor shall keep such books, records, and accounts as may be necessary in order to record complete and correct entries related to this Agreement. Contractor shall preserve and make available, at reasonable times for examination and audit by Town, all financial records, supporting documents, statistical records, and any other documents pertinent to this Agreement for the required retention period of the Florida Public Records Act (Chapter 119, Florida Statutes), if applicable, or, if the Florida Public Records Act is not applicable, for a minimum period of the later of three (3) years after termination or expiration of this Agreement, unless Contractor is notified in writing by Town of the need to extend the retention period. Such retention of such records and documents shall be at Contractor's sole expense. If any audit has been initiated and audit findings have not been resolved at the end of the retention period or the three (3) year period, whichever is later, the books, records, and accounts shall be retained until resolution of the audit findings. If the Florida Public Records Act is determined by Town to be applicable to Contractor's records, Contractor shall comply with all requirements thereof; however, no confidentiality or non-disclosure requirement of either federal or state law shall be violated by Contractor. Any incomplete or incorrect entry in such books, records, and accounts shall be a basis for Town's disallowance and recovery of any payment upon such entry. In addition, Contractor shall respond to the reasonable inquiries of successor Contractors and allow successor Contractors to receive working papers relating to matters of continuing significance. In addition, Contractor shall provide a complete copy of all working papers to the Town, prior to final payment by the Town under this Agreement.

18. DIFFERING SITE CONDITIONS: In the event that during the course of the Work, Contractor encounters subsurface or concealed conditions which differ materially from those shown on the Contract Documents and from those ordinarily encountered and generally recognized as inherent in work of the character called for in the Contract Documents; or unknown physical conditions of an unusual nature, which differ materially from that ordinarily encountered and generally recognized as inherent in work of the character called for in the Contract Documents, Contractor without disturbing the conditions and before performing any Work affected by such conditions, shall, within twenty-four (24) hours of their discovery, notify Contract Manager in writing of the existence of the aforesaid conditions. Contract Manager shall investigate the site conditions identified by

Contractor. If, in the sole opinion of Contract Manager, the conditions do materially so differ and cause an increase or decrease in Contractor's cost of, or the time required for, the performance of any part of the Work, whether or not charged as a result of the conditions, Contract Manager may recommend an equitable adjustment to the Contractor's compensation hereunder. If Contract Manager and Contractor cannot agree on an adjustment in the compensation, the adjustment shall be referred to the Town Administrator for determination in accordance with the provisions of Section 18 above. No request by Contractor for an equitable adjustment to the Agreement under this provision shall be allowed unless Contractor has given written notice to the Contract Manager in strict accordance with the provisions of this Section.

19. LOCATION AND DAMAGE TO EXISTING FACILILTIES, EQUIPMENT OR UTILITIES:

19.1. Town does not guarantee that all lines are shown, or that the ones indicated are in their true location. It shall be the Contractor's responsibility prior to commencement of any Work to identify and locate all underground and overhead utility lines or equipment affecting or affected by the Work. No additional payment will be made to the Contractor because of discrepancies in actual and planned location of utilities, and additional costs suffered as a result thereof.

19.2. The Contractor shall notify each utility company involved at least thirty (30) days prior to the start of construction to arrange for positive underground location, relocation or support of its utility where that utility may be in conflict with or endangered by the proposed construction. Relocation of water mains or other utilities for the convenience of the Contractor shall be paid by the Contractor. All charges by utility companies for temporary support of its utilities shall be paid for by the Contractor. All costs of permanent utility relocation to avoid conflict shall be the responsibility of the utility company involved. No additional payment will be made to the Contractor for utility relocations, whether or not said relocation is necessary to avoid conflict with other lines.

19.3. The Contractor shall schedule the Work in such a manner that the Work is not delayed by the utility providers relocating or supporting their utilities. The Contractor shall coordinate its activities with any and all public and private utility providers occupying the right-of-way. No compensation will be paid to the Contractor for any loss of time or delay.

19.4. All overhead, surface or underground structures and utilities encountered are to be carefully protected from injury or displacement. All damage to such structures is to be completely repaired within a reasonable time; needless delay will not be tolerated. The Town reserves the right to remedy such damage by ordering outside parties to make such repairs at the expense of the Contractor. All such repairs made by the Contractor are to be made to the satisfaction of the utility owner. All damaged utilities must be replaced or fully repaired. All repairs are to be inspected by the utility owner prior to backfilling.

19.5. The foregoing provisions of this Section 19 relating to costs and/or delays incurred by Contractor due to underground structures and utilities are subject to Section 18 above; provided however, that under no circumstances shall Contractor be entitled to an equitable adjustment in compensation where Contractor knew or could have discovered through the exercise of due diligence, the existence and/or location of such underground structures and utilities.

20. NOTIFICATION OF CLAIM FOR CHANGE OF CONTRACT PRICE OR DAMAGES:

Any claim for a change in compensation or for damages shall be made by written notice by Contractor to the Contract Manager within five (5) calendar days of the commencement of the event giving rise to the claim or knowledge by Contractor of the claim and the notice shall state the general nature and cause of the claim.

Thereafter, within twenty (20) calendar days of the termination of the event giving rise to the claim or knowledge of the claim, written notice of the extent of the claim with supporting information and documentation shall be submitted to the Contract Manager (hereinafter "Claim Notice"). The Claim Notice shall include Contractor's written notarized certification that the adjustment claimed is the entire adjustment to which the Contractor has reason to believe it is entitled as a result of the occurrence of said event. If the Contract Manager and Contractor cannot resolve a claim as set forth in a proper Claim Notice within twenty (20) calendar days after receipt by the Contract Manager, then Contractor shall submit the claim to Town Administrator within ten (10) calendar days from the date of impasse in accordance with Section 16 above. **IT IS EXPRESSLY AND SPECIFICALLY AGREED THAT ANY AND ALL CLAIMS FOR CHANGES TO CONTRACT PRICE SHALL BE WAIVED IF NOT SUBMITTED IN STRICT ACCORDANCE WITH THE REQUIREMENTS OF THIS SECTION.**

21. NOTICES: Whenever either party desires to give notice to the other, such notice must be in writing by certified or registered mail, postage prepaid, return receipt requested, hand delivery, or facsimile transmission prior to 5:00 p.m. on the date of transmission (e.d.t. or e.s.t. as applicable), or via overnight express courier service. For the present, the parties designate the following individuals as the respective parties and places for the giving of notice:

If to Town:

Town of Southwest Ranches
Town Administrator
13400 Griffin Road
Southwest Ranches, Florida 33330

With a copy to:

Keith M. Poliakoff, J.D.
Arnstein & Lehr
200 East Las Olas Boulevard
Suite 1700
Fort Lauderdale, Florida 33301

If to Contractor:

22. GOVERNING LAW AND VENUE: Refer to Section 21 of the RFP.

23. SEVERABILITY: Refer to Section 25 of the RFP.

24. SOVEREIGN IMMUNITY: Nothing in this Agreement is intended nor shall it be construed or interpreted to waive or modify the Town's Sovereign Immunity defense or any other of the Town's immunities and limitations on liability as provided for in the Florida Statutes, as now worded or as may hereafter be amended, and all Florida case law interpreting same.

25. FUNDING: The obligation of Town for payment to Contractor for the Work is limited to the availability of funds appropriated in a current fiscal period, and continuation of any contractual relationship into a subsequent fiscal period is subject to appropriation of funds, unless otherwise authorized by law. In the event the funds to finance the Work under this Agreement become unavailable, Town may provide Contractor with thirty (30) days written notice of termination. Nothing in this Agreement shall be deemed or construed to prevent the parties from negotiating a new Agreement in this scenario. In the event that Town elects to terminate Contractor for lack of funds as provided for in this paragraph, and Town's termination for lack of funds is later determined by a court of competent jurisdiction to be improper, or in any other way wrongful or in breach of this Agreement, the termination shall automatically be deemed converted to a termination for convenience and Contractor shall be paid solely in accordance with Section 12 above.

26. PUBLIC RECORDS: The Town is subject to Chapter 119, Florida Statutes, "Public Records Law." No claim of confidentiality or proprietary information in all or any portion of a response will be honored unless a specific exemption from the Public Records Law exists and it is cited in the response. An incorrectly claimed exemption does not disqualify the firm, only the exemption claimed. Contractor understands that the public shall have access, at all reasonable times, to all documents and information pertaining to Town's contracts, subject to the provisions of Chapter 119, Florida Statutes, and agrees to allow access by the Town and the public to all documents subject to disclosures under applicable law. Contractor's failure or refusal to comply with the provisions of this Section shall result in the immediate cancellation and/or termination of this Agreement by Town. To the extent that Contractor has been provided access to or has received security sensitive information, as defined by Florida Statutes, Section 119.071 and/or has executed a Confidential Information Acknowledgement and Agreement as part of the proposal process, Contractor shall keep and maintain the security sensitive information as confidential and exempt from public disclosures as required by Florida Statutes.

27. PUBLIC ENTITY CRIMES INFORMATION STATEMENT: Pursuant to Florida Statutes, Section 287.133: "A person or affiliate who has been placed on the convicted vendor list following a conviction for a public entity crime may not submit a bid, proposal, or reply on a contract to provide any goods or services to a public entity; may not submit a bid, proposal, or reply on a contract with a public entity for the construction or repair of a public building or public work; may not submit bids, proposals, or replies on leases of real property to a public entity; may not be awarded or perform work as a contractor, supplier, subcontractor, or consultant under a contract with any public entity; and may not transact business with any public entity in excess of the threshold amount provided in s. 287.017 for CATEGORY TWO for a period of 36 months following the date of being placed on the convicted vendor list." Violation of this Section by Contractor shall result in Town's immediate termination of this Agreement.

28. NO WAIVER OF RIGHTS: Neither the Town's review, approval or payment for any of the Work required under this Agreement shall be construed to operate as a waiver of any of Towns rights or remedies under this Agreement or of any causes of action arising out Contractor's performance of the Work under this Agreement, and Contractor shall be and remain liable to the Town for all damages to the Town caused by the Contractor's negligent or improper performance of any of the Work furnished under this Agreement, irrespective of the Town's review, approval or payment for any of the Work under this Agreement. The rights and remedies of the Town provided for under this Agreement are in addition to all other rights and remedies provided to Town by law or in equity.

29. WAIVER OF RIGHT TO JURY TRIAL: BY ENTERING INTO THIS AGREEMENT, CONTRACTOR AND TOWN HEREBY EXPRESSLY WAIVE ANY RIGHTS EITHER PARTY MAY HAVE TO A TRIAL BY JURY IN ANY CIVIL LITIGATION RELATED TO, OR ARISING OUT OF THIS AGREEMENT.

30. NO AMENDMENT OR WAIVER: This Agreement may not be changed, altered or modified except by an instrument in writing signed by all parties hereto, with the same formality and of equal dignity as the execution of this Agreement prior to the initiation of any Work reflecting such change.

31. CHAPTER 558, FLORIDA STATUTES, NOT APPLICABLE. The parties understand and agree that Chapter 558, Florida Statutes, does not apply to this Agreement or the Work, and that the parties hereby “opt out” of the procedures set forth at Chapter 558, Florida Statutes.

32. MISCELLANEOUS:

A. Ownership of Documents. Unless otherwise provided by law, any and all reports, surveys, and other data and documents provided or created in connection with this Agreement by Contractor and all persons or entities employed or otherwise retained by Contractor are and shall remain the property of Town. In the event of termination of this Agreement for any reason, any reports, photographs, surveys and other data and documents prepared by Contractor, whether finished or unfinished, shall become the property of Town and shall be delivered by Contractor to the Town Administrator within seven (7) days of termination of this Agreement for any reason. Any compensation due to Contractor shall be withheld until all documents are received by Town as provided herein.

B. Independent Contractor. Contractor is an independent contractor of Town under this Agreement. Services provided by Contractor pursuant to this Agreement shall be subject to the supervision of Contractor. In providing such services, neither Contractor nor its agents shall act as officers, employees or agents of the Town. Personnel policies, tax responsibilities, social security and health insurance, employee benefits, purchasing policies and other similar administrative procedures applicable to the Work and services rendered under this Agreement shall be exclusively and solely those of Contractor. This Agreement shall not constitute or make Town and Contractor a partnership or joint venture.

C. Conflicts. Neither Contractor nor its employees shall have or hold any continuing or frequently recurring employment or contractual relationship that is substantially antagonistic or incompatible with Contractor’s loyal and conscientious exercise of judgment related to its performance under this Agreement.

Contractor agrees that none of its officers or employees shall, during the term of this Agreement, serve as an expert witness against Town in any legal or administrative proceeding in which he or she is not a party, unless compelled by court process. Further, Contractor agrees that such persons shall not give sworn testimony or issue a report or writing, as an expression of his or her expert opinion, which is adverse or prejudicial to the interests of Town in connection with any such pending or threatened legal or administrative proceeding. The limitations of this Section shall not preclude Contractor or any other persons from representing themselves in any action or in any administrative or legal proceeding.

In the event Contractor is permitted to utilize subcontractors to perform any services required by this Agreement, Contractor agrees to prohibit such subcontractors, by written contract, from having any conflicts within the meaning of this paragraph C of Section 32.

- D. Contingency Fee.** Contractor warrants that it has not employed or retained any company or person, other than a bona fide employee working solely for Contractor, to solicit or secure this Agreement and that it has not paid or agreed to pay any person, company, corporation, individual or firm, other than a bona fide employee working solely for Contractor, any fee, commission, percentage, gift, or other consideration contingent upon or resulting from the award or making of this Agreement. For a breach or violation of this provision, Town shall have the right to terminate this Agreement without liability and, at its discretion, to deduct from the Contract Price or otherwise recover the full amount of such fee, commission, percentage, gift or consideration.
- E. Materiality and Waiver of Breach.** Town and Contractor agree that each requirement, duty, and obligation set forth herein is substantial and important to the formation of this Agreement and, therefore, is a material term hereof. Town's failure to enforce any provision of this Agreement shall not be deemed a waiver of such provision or modification of this Agreement. A waiver of any breach of a provision of this Agreement shall not be deemed a waiver of any subsequent breach and shall not be construed to be a modification or continuing waiver of the terms of this Agreement.
- F. Joint Preparation.** Town and Contractor both acknowledge that they have sought and received whatever competent advice and legal counsel as was necessary for them to form a full and complete understanding of all rights and obligations herein and that the preparation of this Agreement has been their joint effort. The language agreed to herein express their mutual intent and the resulting document shall not, solely as a matter of judicial construction, be construed more severely against one of the parties over the other.
- G. Drug-Free Workplace.** Contractor agrees that it shall maintain a drug-free workplace as set forth in the RFP.
- H. Headings.** Headings are for convenience of reference only and shall not be considered in any interpretation of this Agreement.
- I. Binding Authority.** Each person signing this Agreement on behalf of either party individually warrants that he or she has full legal power to execute this Agreement on behalf of the party for whom he or she is signing, and to bind and obligate such party with respect to all provisions contained in this Agreement.
- J. Truth-in-Negotiation Certificate.** Signature of this Agreement by Contractor shall act as the execution of a truth-in-negotiation certificate stating that wage rates and other factual unit costs supporting the compensation of this Agreement are accurate, complete, and current at the time of contracting.

IN WITNESS WHEREOF, the parties have made and executed this Agreement on the respective dates under each signature: _____, and the TOWN OF SOUTHWEST RANCHES, signing by and through its Mayor duly authorized to execute same by Council action on the ___ day of _____ 2014.

WITNESSES:

CONTRACTOR:

By: _____
_____, _____ (title)
____ day of _____ 201_

TOWN OF SOUTHWEST RANCHES

By: _____
Jeff Nelson, Mayor
____ day of _____ 201_

By: _____
Andrew D. Berns, Town Administrator
____ day of _____ 201_

ATTEST:

Russell Muñiz, MMC, Town Clerk

APPROVED AS TO FORM AND CORRECTNESS:

Keith M. Poliakoff, Town Attorney
IWOV-ACTIVE.FID1670820

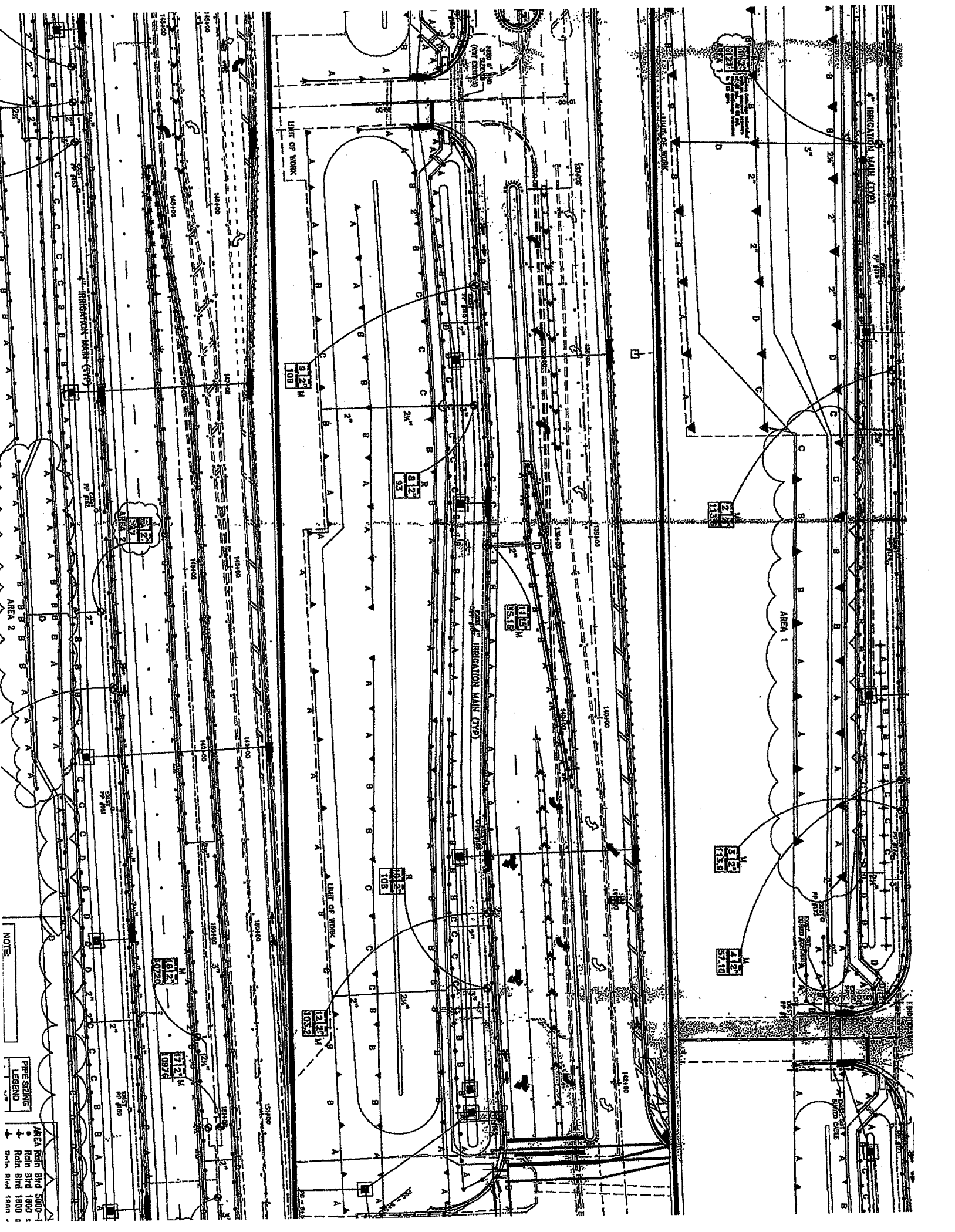

NOTE:

PIPE SIZING
LEGEND

AREA 1
AREA 2
AREA 3

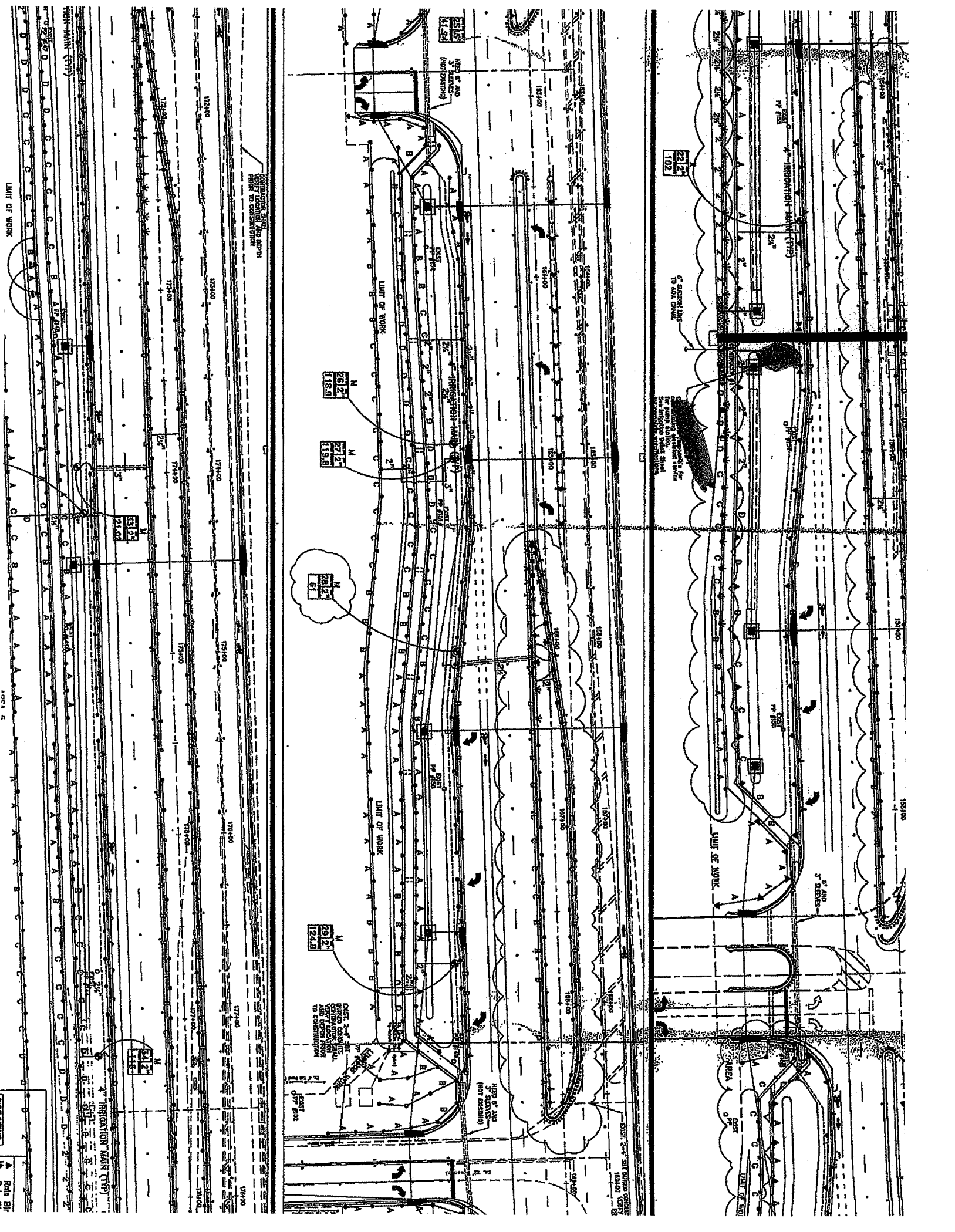

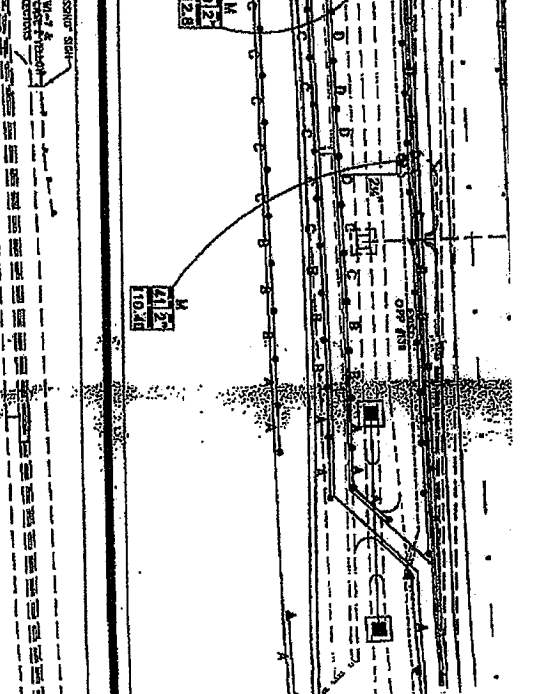
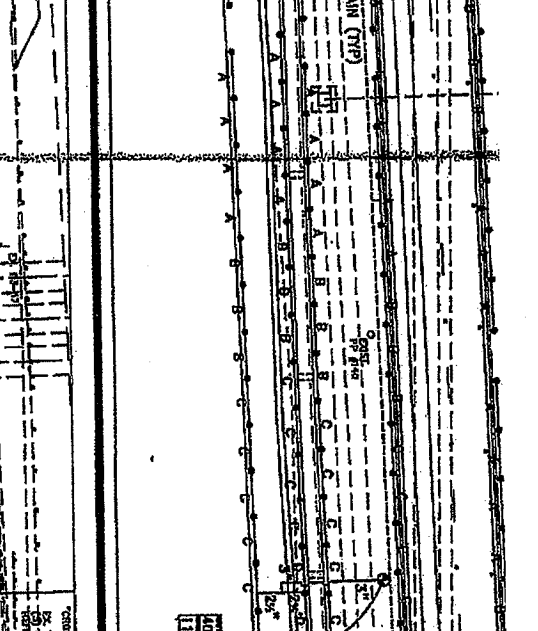
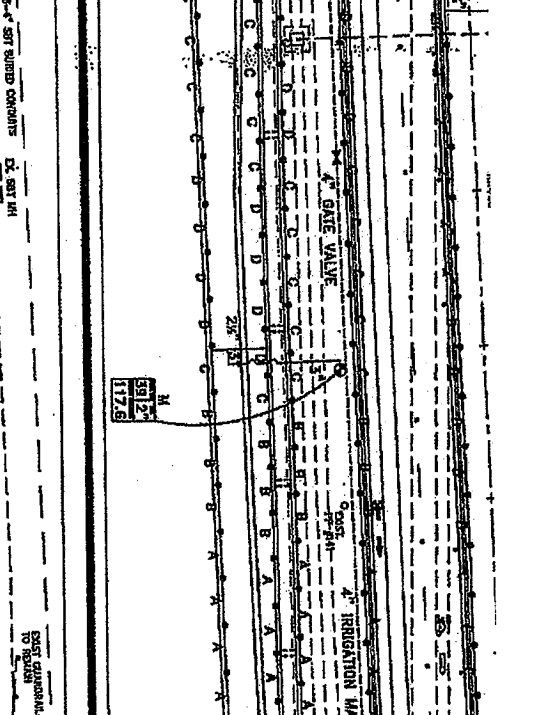
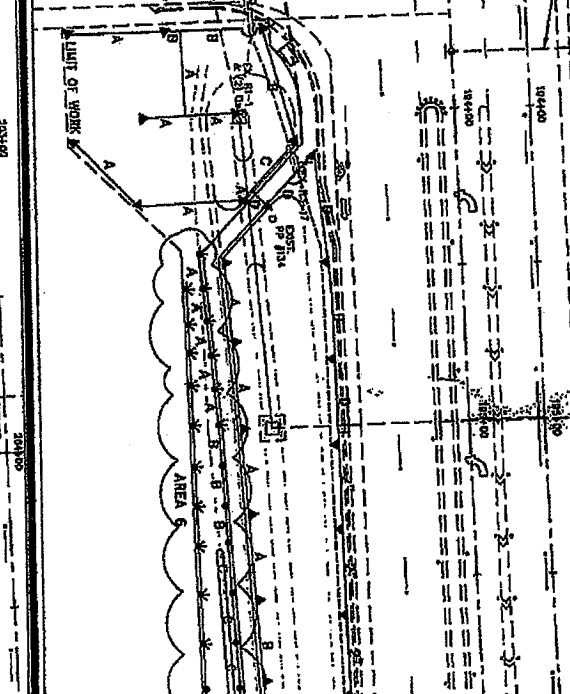
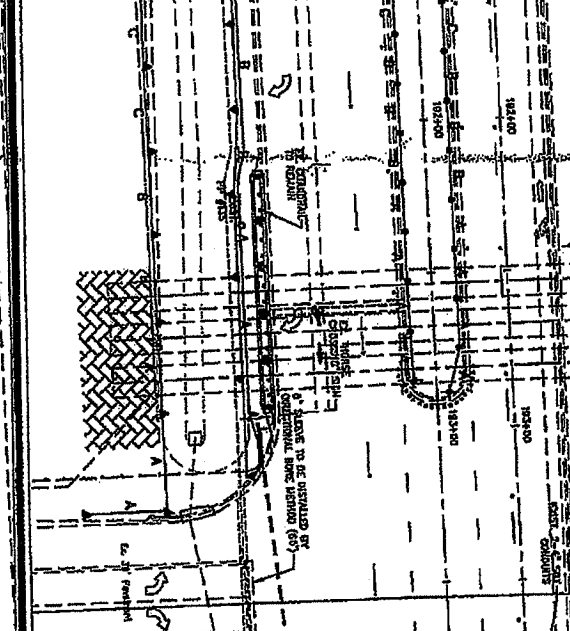
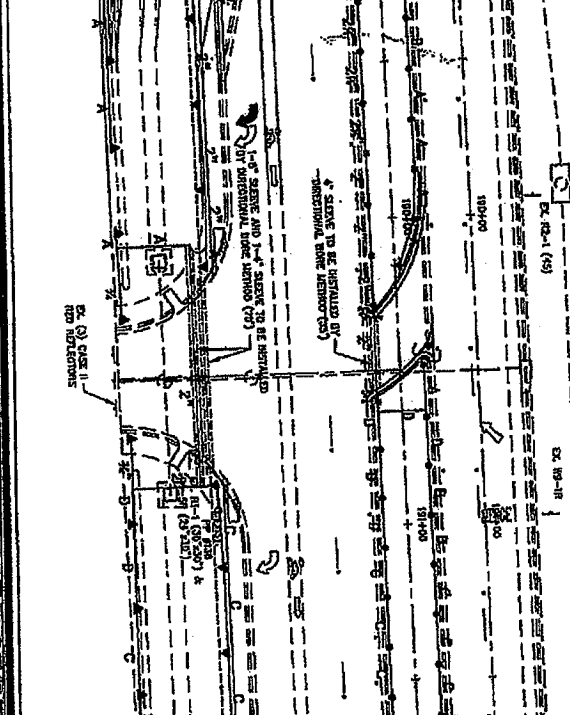
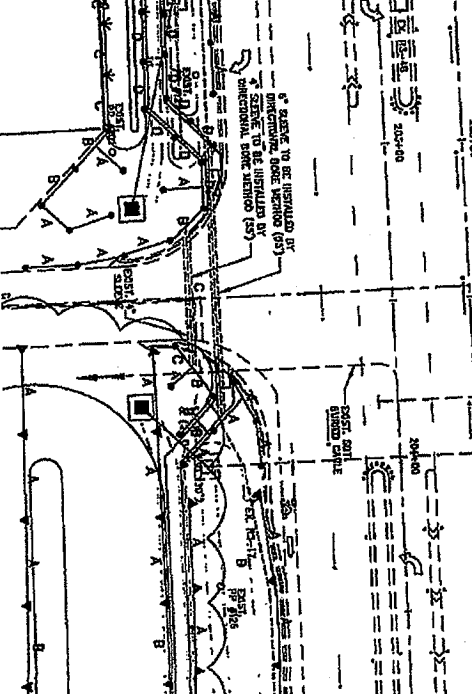
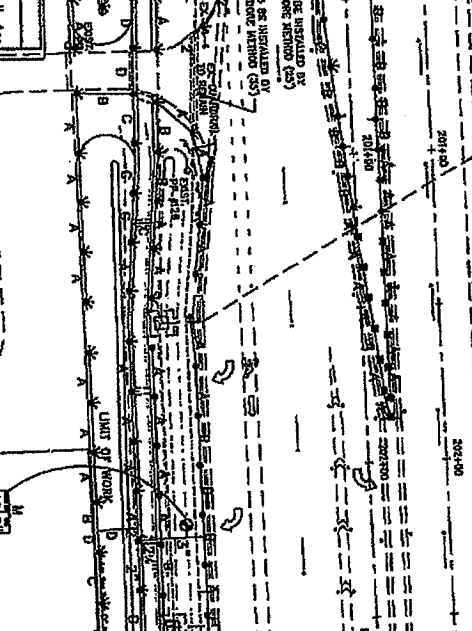
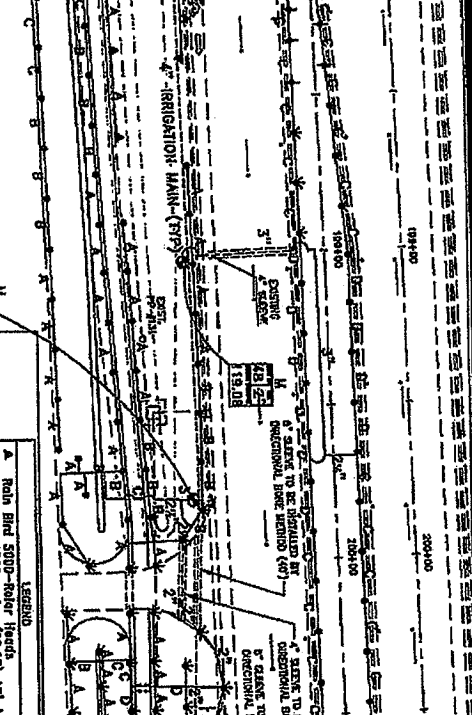
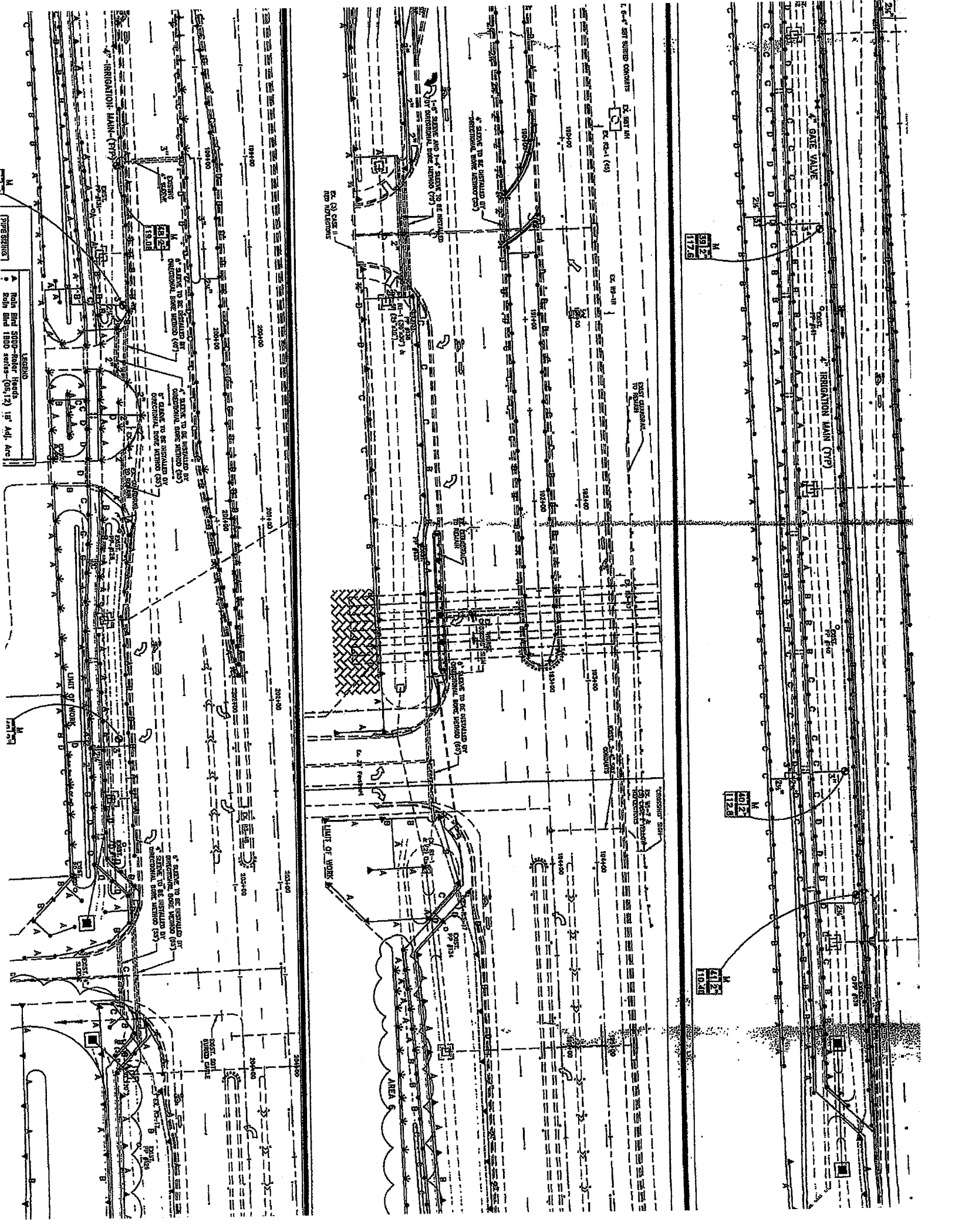

TYPE STRINGS

Rain Bird 5000-Roller Heads
Rain Bird 1800 series (05/12) 1/2" Adj. Arc

LEGEND

LIMIT OF WORK

CONSUMER SIDE

AREA

CONSUMER SIDE

CONSUMER SIDE

CONSUMER SIDE

4\"/>

4\"/>

4\"/>

4\"/>

4\"/>

4\"/>

4\"/>

4\"/>

4\"/>

4\"/>

4\"/>

4\"/>

4\"/>

4\"/>

4\"/>

4\"/>

4\"/>

4\"/>

4\"/>

4\"/>

4\"/>

4\"/>

4\"/>

4\"/>

4\"/>

4\"/>

4\"/>

4\"/>

4\"/>

4\"/>

4\"/>

4\"/>

4\"/>

4\"/>

4\"/>

4\"/>

4\"/>

4\"/>

4\"/>

4\"/>

4\"/>

4\"/>

4\"/>

4\"/>

4\"/>

4\"/>

4\"/>

4\"/>

4\"/>

4\"/>

4\"/>

4\"/>

4\"/>

4\"/>

4\"/>

4\"/>

4\"/>

4\"/>

4\"/>

4\"/>

4\"/>

4\"/>

4\"/>

4\"/>

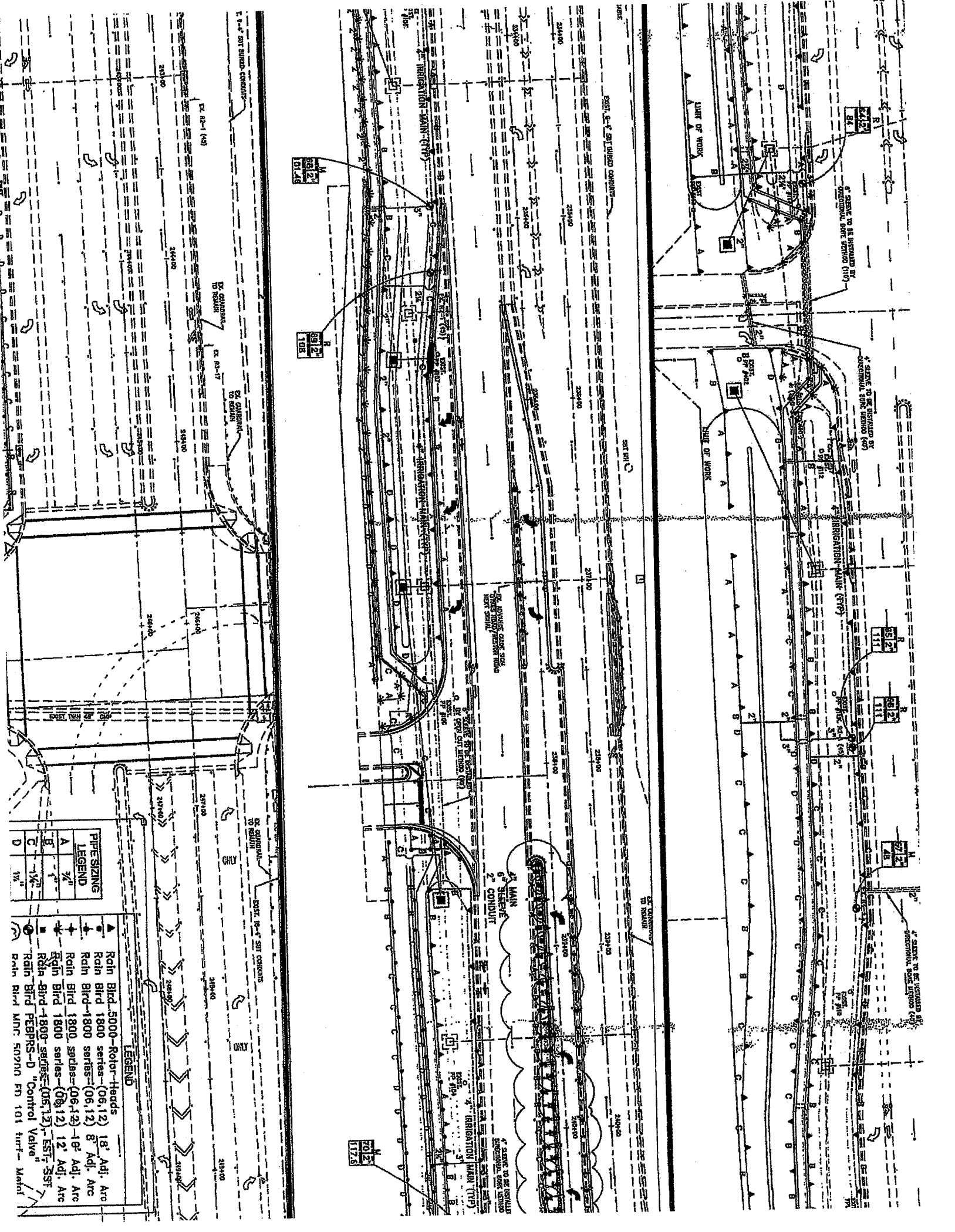

PIPE SIZING LEGEND

A	3/4"
B	1"
C	1 1/2"
D	2"

LEGEND

▲	Rain Bird 5000-Rotor-Hands	18" Adj. Arc
▲	Rain Bird 1800 series-(06,12)	8" Adj. Arc
▲	Rain Bird 1800 series-(06,12)	10" Adj. Arc
▲	Rain Bird 1800 series-(06,12)	12" Adj. Arc
▲	Rain Bird 1800 series-(06,12)	EST. 35FT
▲	Rain Bird 1800 series-(06,12)	EST. 35FT
▲	Rain Bird PEAPRS-D "Control Valve"	
▲	Rain Bird MNC 5027M FD 101 turf-Mark I	

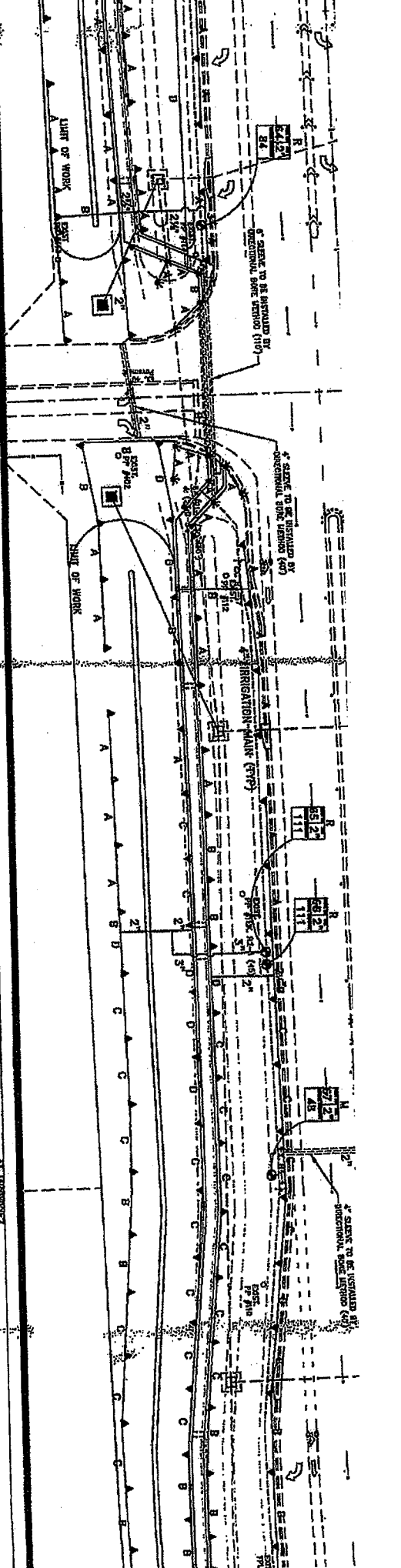
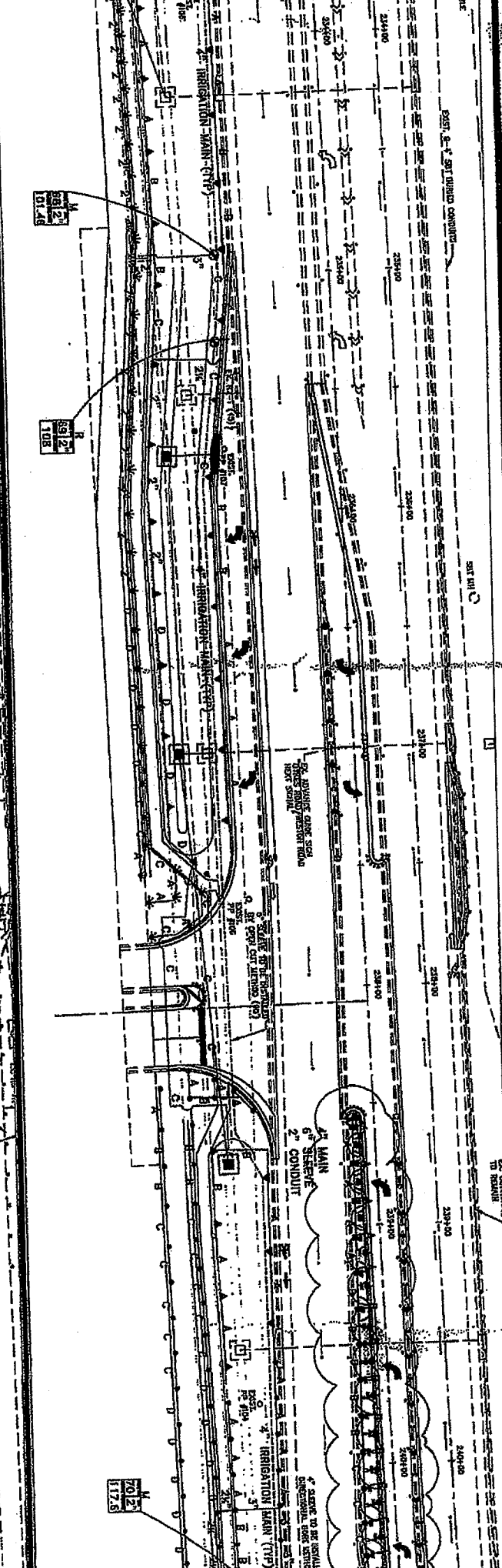
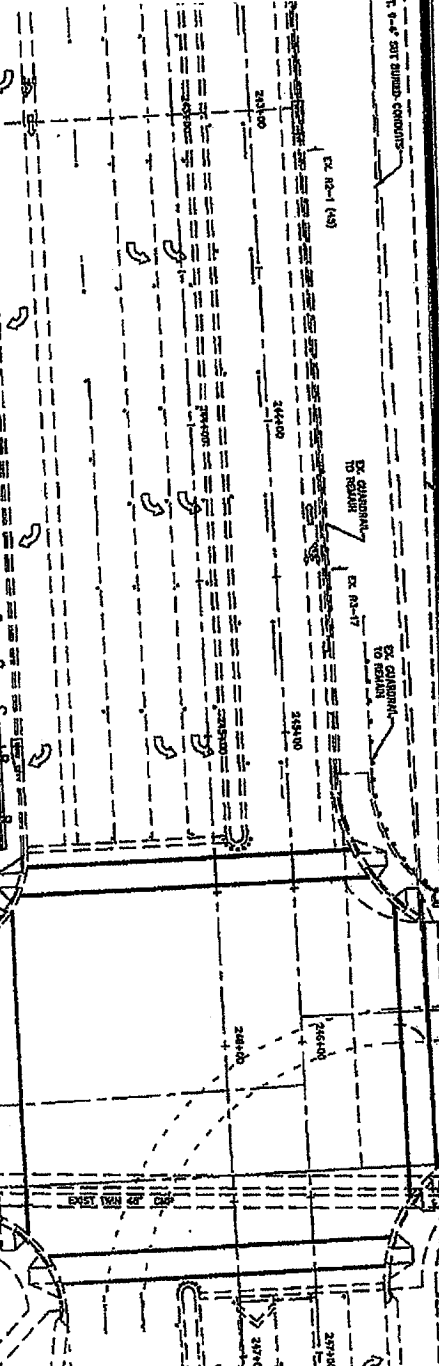

Chg. Rate	Program %	Run Time	Start Time	End Time	Day	Program %	Run Time	Start Time	End Time	Day
1.437/hr	15	14:15PM	TUES	30	FRI	6:30PM	FRI			
1.437/hr	15	11:30PM	TUES	30	FRI	7:00PM	FRI			
1.437/hr	15	11:45PM	TUES	30	FRI	7:30PM	FRI			
1.437/hr	60	12:00AM	WED	120	FRI	8:00PM	FRI			
1.437/hr	15	1:00AM	SAT	30	FRI	10:00PM	FRI			
1.437/hr	15	1:45AM	WED	30	FRI	10:30PM	FRI			
1.437/hr	60	3:00AM	WED	120	FRI	11:00PM	FRI			
1.437/hr	15	2:30AM	SAT	30	FRI	1:00AM	FRI			
1.437/hr	15	2:45AM	WED	30	FRI	1:30AM	FRI			
1.437/hr	60	3:00AM	SAT	120	FRI	2:00AM	FRI			
1.437/hr	15	4:00AM	SAT	30	FRI	4:00AM	FRI			
1.437/hr	60	4:00AM	WED	120	FRI	6:00AM	FRI			
1.437/hr	60	6:00AM	WED	120	FRI	8:00AM	FRI			
1.437/hr	60	7:00AM	WED	120	FRI	10:00AM	FRI			
1.437/hr	15	7:45AM	SAT	30	FRI	10:30AM	FRI			
1.437/hr	15	7:30AM	WED	30	FRI	11:00AM	FRI			
1.437/hr	15	7:45AM	WED	30	FRI	11:30AM	FRI			
1.437/hr	15	7:45AM	WED	30	FRI	8:00AM	FRI			

IST PUMP STATION @ STA. 155+50

Chg. Rate	Program %	Run Time	Start Time	End Time	Day	Program %	Run Time	Start Time	End Time	Day
1.437/hr	60	12:00AM	WED	120	FRI	6:00PM	FRI			
1.437/hr	15	1:00AM	SAT	30	FRI	8:00PM	FRI			
1.437/hr	15	1:45AM	WED	30	FRI	8:30PM	FRI			
1.437/hr	60	1:30PM	WED	120	FRI	8:00PM	FRI			
1.437/hr	60	1:45PM	WED	120	FRI	8:30PM	FRI			
1.437/hr	15	2:45AM	SAT	30	FRI	11:30PM	FRI			
1.437/hr	15	3:00AM	WED	30	FRI	12:00AM	FRI			
1.437/hr	15	3:15AM	SAT	30	FRI	12:30AM	FRI			
1.437/hr	60	3:30AM	WED	120	FRI	1:00AM	FRI			
1.437/hr	60	4:30AM	WED	120	FRI	3:00AM	FRI			
1.437/hr	15	5:30AM	SAT	30	FRI	5:00AM	FRI			
1.437/hr	15	5:45AM	WED	30	FRI	5:30AM	FRI			
1.437/hr	60	6:00AM	WED	120	FRI	6:00AM	FRI			
1.437/hr	60	6:15AM	SAT	30	FRI	6:30AM	FRI			
1.437/hr	60	6:30AM	WED	120	FRI	6:30AM	FRI			
1.437/hr	15	6:45AM	SAT	30	FRI	7:00AM	FRI			
1.437/hr	15	6:30AM	WED	30	FRI	7:30AM	FRI			
1.437/hr	15	7:00AM	WED	30	FRI	8:00AM	FRI			
1.437/hr	15	7:15AM	WED	30	FRI	8:30AM	FRI			
1.437/hr	15	7:15AM	WED	30	FRI	8:00AM	FRI			
1.437/hr	15	7:15AM	WED	30	FRI	8:00AM	FRI			

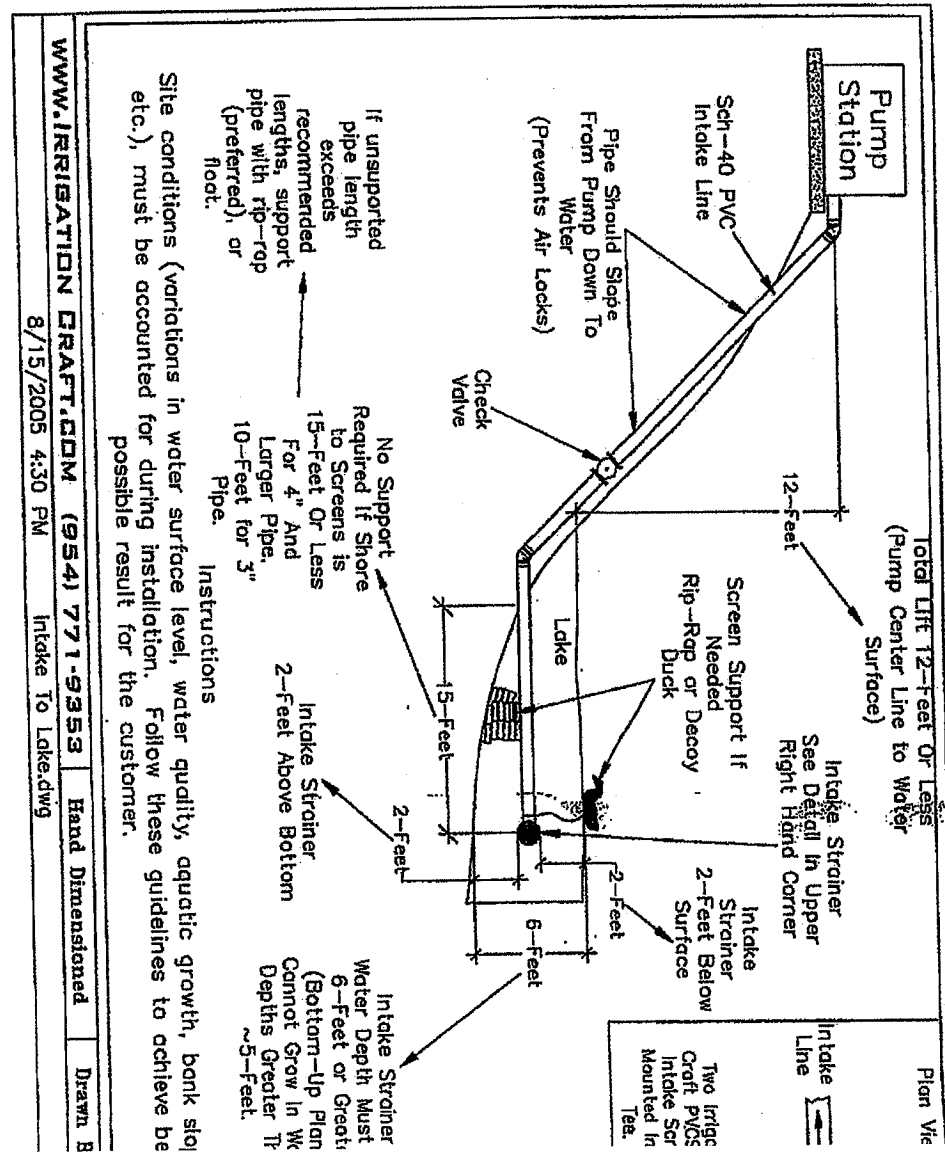

N.T.S.

www.IRIGATIONGRAFT.COM (954) 771-9353 Hand Dimensioned Drawn B
 8/15/2005 4:30 PM Intake To Lake.dwg

100% overlap

PAINTED FLAT BLACK. MAKE ADJUSTMENTS TO THE IRRIGATION SYSTEM TO INSURE 100% COVERAGE AND TO MINIMIZE OVERSPRAY. SUBSTITUTE ADJUSTABLE NOZZLES FOR FIXED PATTERN NOZZLES SPECIFIED WHERE NECESSARY. RUN 3 ADDITIONAL SETS OF WIRES IN EACH DIRECTION TO EACH END OF THE MAIN FOR FUTURE USE. BE RESPONSIBLE FOR HAND WIRING ALL ELECTRICAL SERVICE CONNECTIONS. SLEEVES WILL BE INCLUDED IN THE PAVEMENT SHALL BE SCH. 80. AND THE COST FOR THESE SLEEVES WILL BE INCLUDED IN THE IRRIGATION SYSTEM. THE IRRIGATION CONTRACTOR SHALL COORDINATE WITH THE ROADWAY CONTRACTOR TO INSURE TALLED PRIOR TO CONSTRUCTION OF ROAD, CURBS AND SIDEWALKS. ALSO PROVIDED & LOCATIONS ARE ACCOMPANIED WITH A 2" SCH. 40 ELECTRICAL SLEEVE FOR THE CONTROL WIRING. (ALSO PROVIDED & FOR)

BE SOLELY RESPONSIBLE TO CONTACT THE ENGINEER FOR HYDROSTATIC AND OPERATIONAL TESTING. PLACED IN SLEEVES SHALL BE SCH. 40 SOLVENT WELD WITH ADEQUATE RESTRAINTS. THE SLEEVE SHALL BE A LARGER THAN THE ENCASED PIPE DIAMETER.

AND/OR DEPICTED ON THE PLAN SHEETS REPRESENT APPROXIMATE LOCATION ONLY. AND ARE FOR THE FINAL LOCATION OF ALL COMPONENTS SHALL BE SUBJECT TO APPROVAL BY THE ENGINEER.

DIVIDE POWER SUPPLY FOR IRRIGATION PUMPS IN ACCORDANCE WITH ALL NOTES AND DETAILS. COORDINATE LOCATION - RICHARD BANSEY 954-442-6349.

OR EXACT HEAD LOCATION.

TRADE NAMES ARE SPECIFIED DUE TO REQUEST BY MAINTAINING AUTHORITIES. (TOWN OF SOUTHWEST) COORDINATE WITH OTHER TOWN SYSTEMS. ALL SUBSTITUTIONS TO MATERIALS SPECIFIED SHALL BE APPROVED MAINTAINING AUTHORITIES.

CONSTRUCTION IS NOT SHOWN ON THESE IRRIGATION PLANS FOR CLARITY.

Prior to Final Payment

for Contractors

INSPECT

LETTER OR NUMBER

ACTOR MAY
TO SIDE INLET

4" SPRINKLER

E NPT X .490
ELBOW

POLY PIPE

PVC SCH 40
TEE OR ELL

1/2-INCH MALE
NPT X .490 INCH
BARB ELBOW

VAL PIPE

ER

NOT TO SCALE

AS APPLICABLE

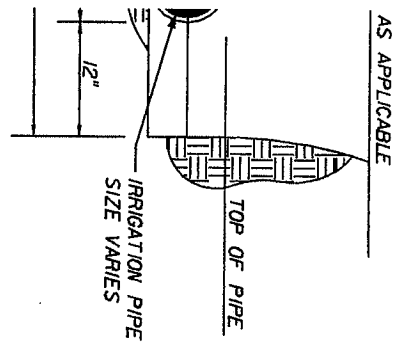

GATION WATER MAIN OR LATERAL
BEDDING SHALL BE COMPACTED
UN DENSITY AS DETERMINED IN
PE C BEDDING SHALL BE DEFINED IN
ING A 9.75 SIEVE, AT LEAST 90
EVE AND A SAND EQUIVALENT

TAIL

NOT TO SCALE

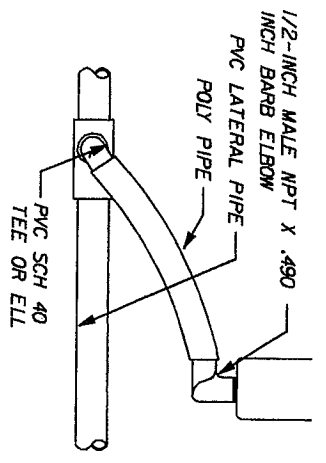

ROTOR DETAIL

NOT TO SCALE

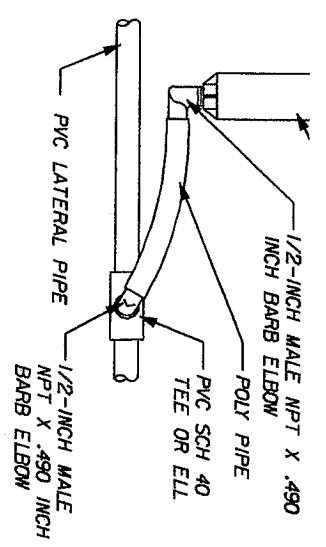

6" POP-UP SPRINKLER

NOT TO SCALE

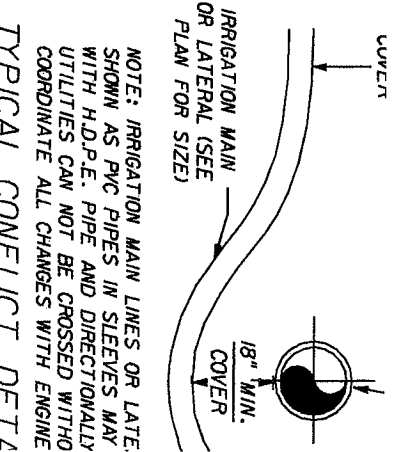

TYPICAL CONFLICT DETA

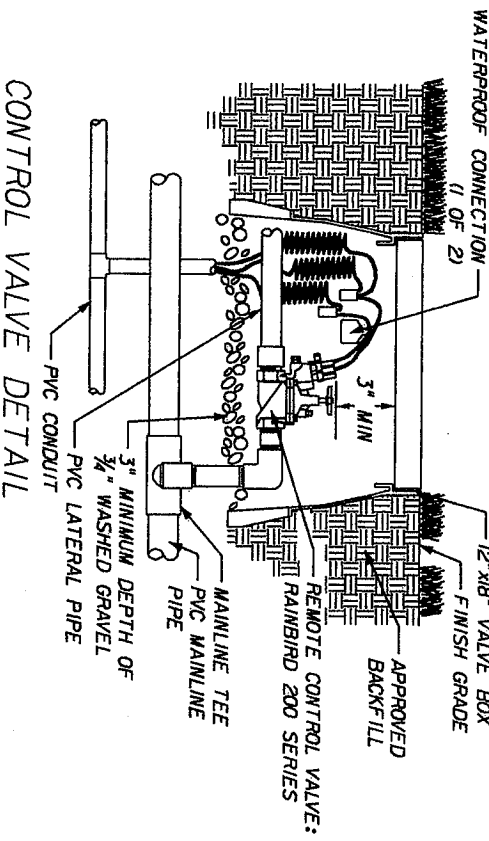

CONTROL VALVE DETAIL

NOT TO SCALE

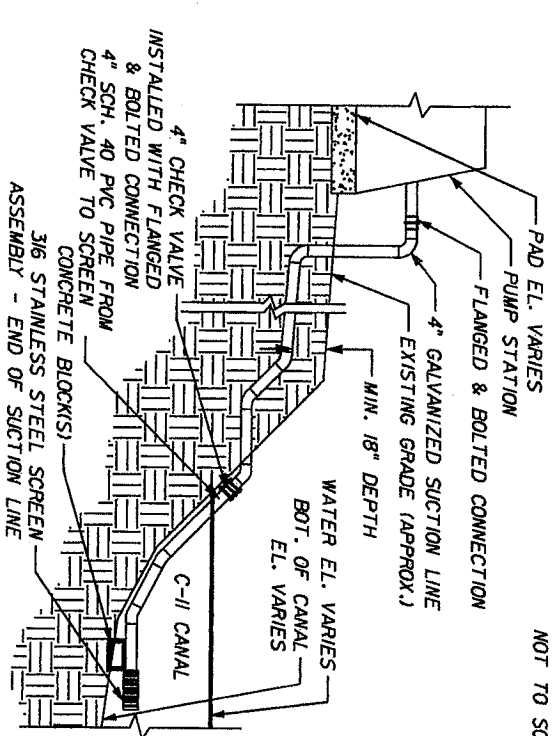

SUCTION LINE DETAIL

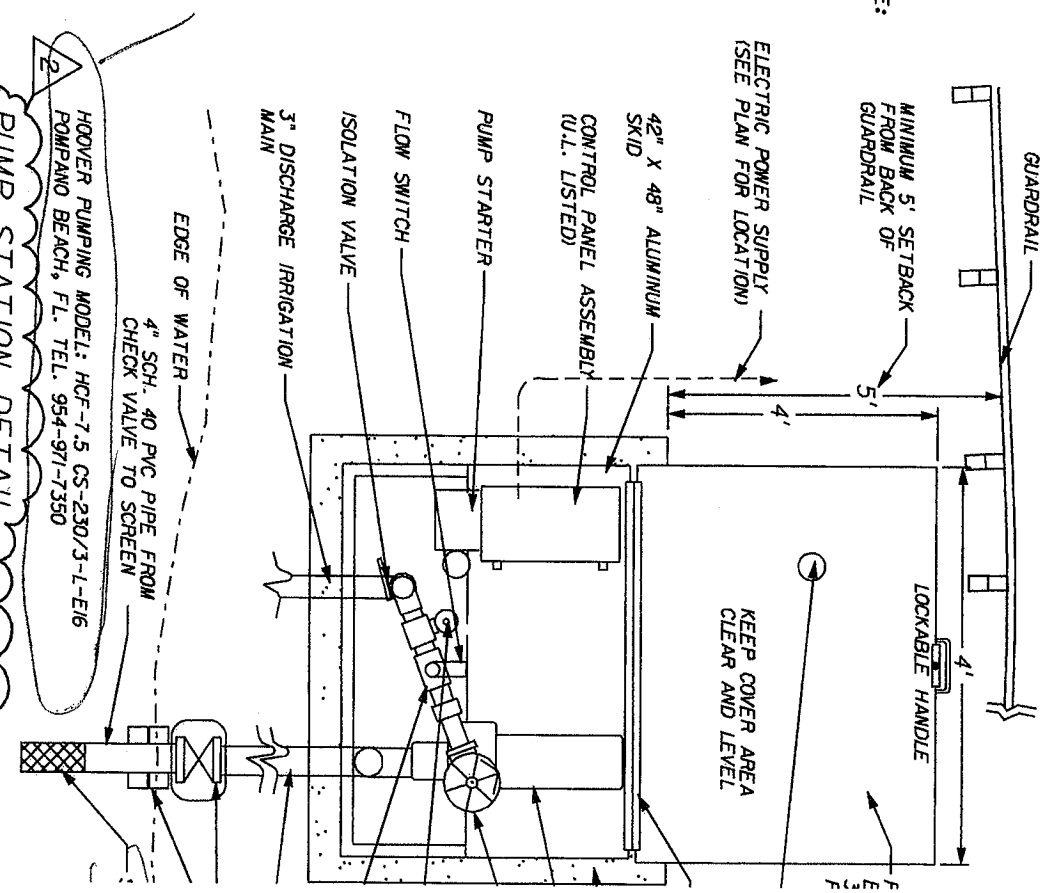

PUMP STATION DETAIL

HOVER PUMPING MODEL: HCF-7.5 CS-230/3-1-E16
POMPANO BEACH, FL. TEL. 954-971-7350

IRRIGATION THIS SHEET -
OWN FOR REFERENCE ONLY

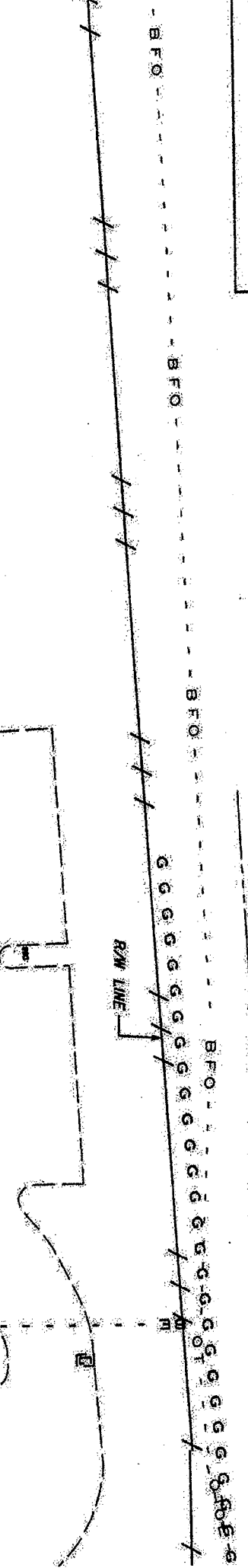

CR 818 GRIFFIN ROAD

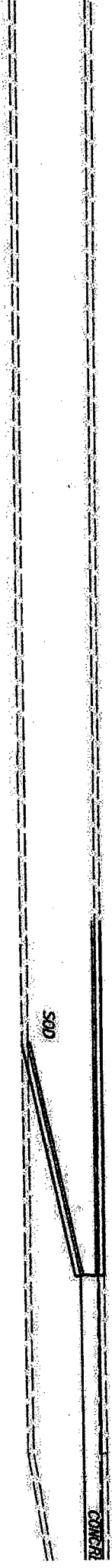

TRAFFIC SEPARATOR (SPECIAL)

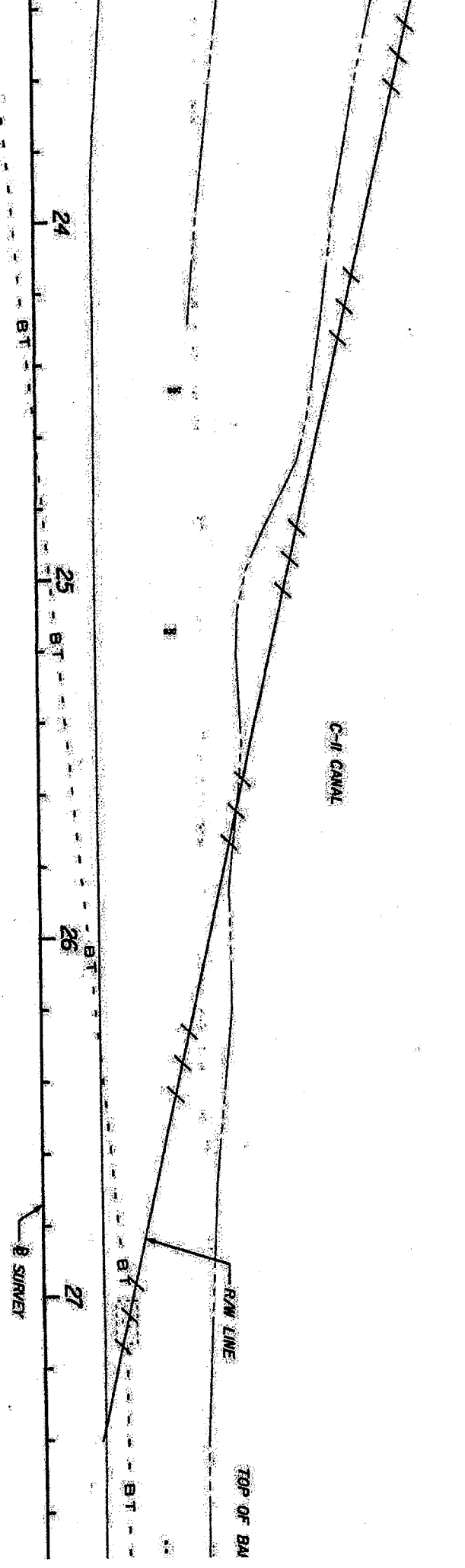

TOP OF BM

BEGIN PROJECT
 BEGIN IRRIGATION
 STA 355+20

C-II CANAL

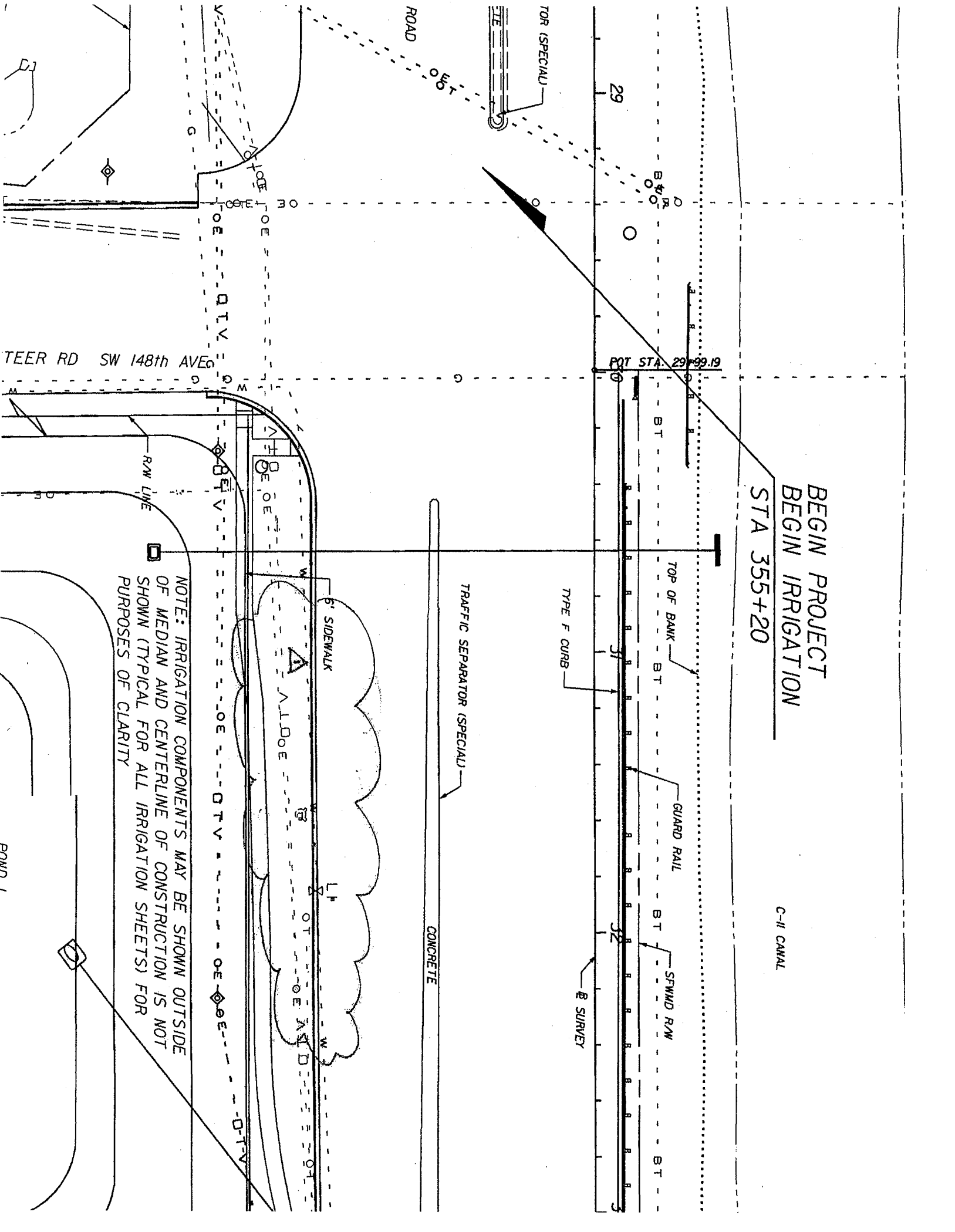

NOTE: IRRIGATION COMPONENTS MAY BE SHOWN OUTSIDE OF MEDIAN AND CENTERLINE OF CONSTRUCTION IS NOT SHOWN (TYPICAL FOR ALL IRRIGATION SHEETS) FOR PURPOSES OF CLARITY

BOND 1

C-11 CANAL

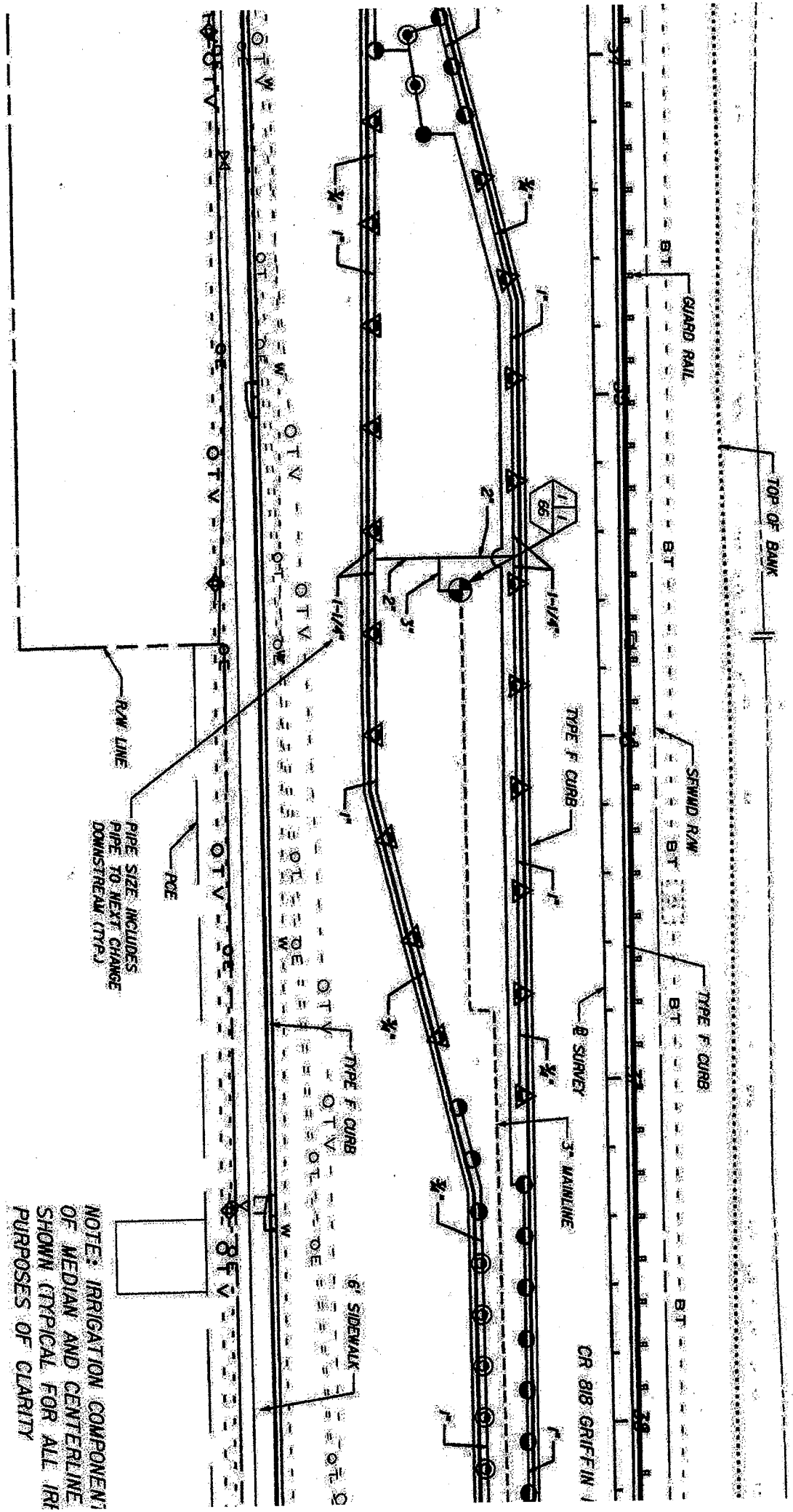

NOTE: IRRIGATION COMPONENT OF MEDIAN AND CENTERLINE SHOWN (TYPICAL FOR ALL IRR PURPOSES OF CLARITY)

C-II CANAL

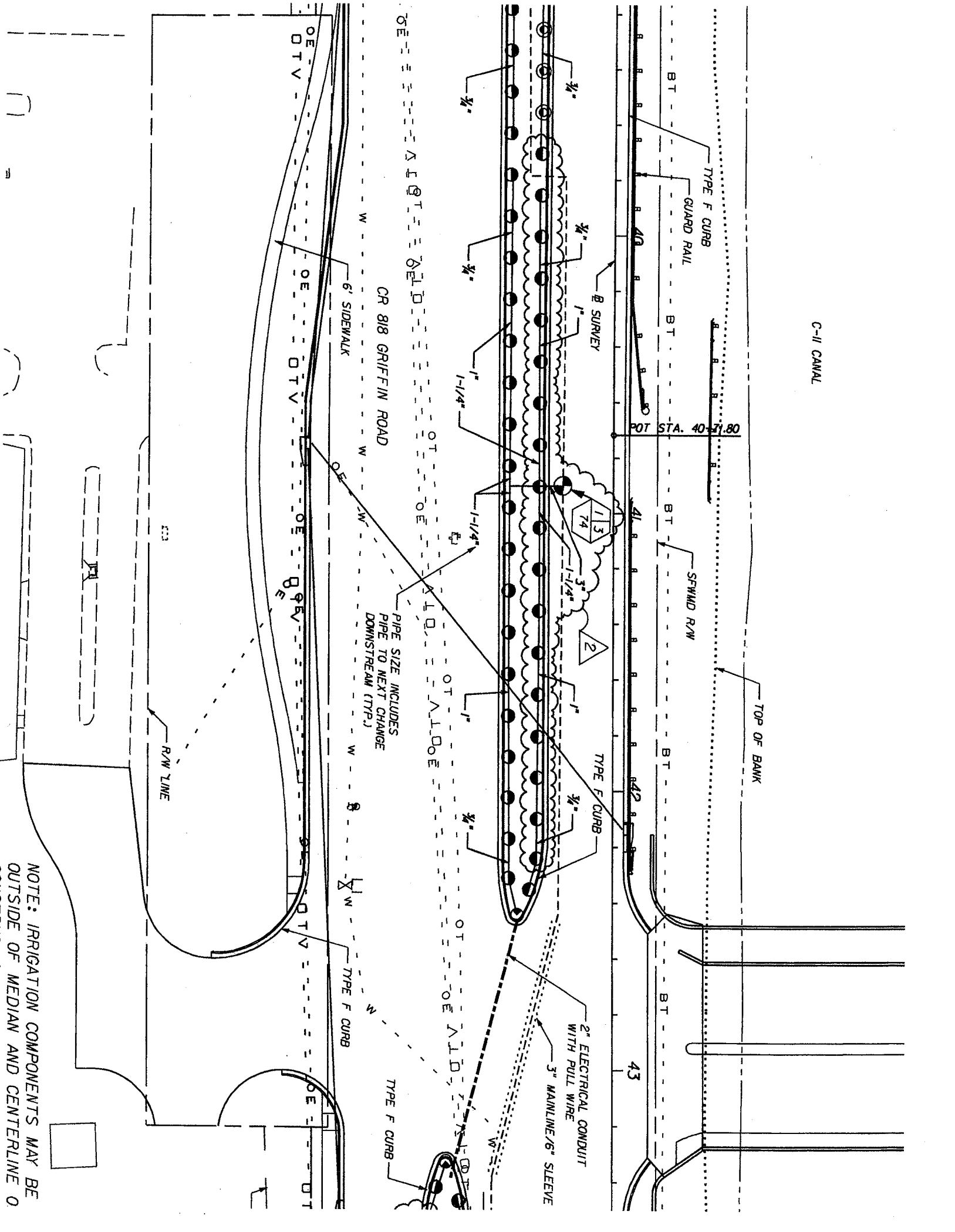

CR 818 GRIFFIN ROAD

PIPE SIZE INCLUDES
PIPE TO NEXT CHANGE
DOWNSTREAM (TYP.)

R/W LINE

POT STA. 40+71.80

TOP OF BANK

SFWD R/W

TYPE F CURB

2" ELECTRICAL CONDUIT
WITH PULL WIRE

3" MAINLINE/6" SLEEVE

B SURVEY

TYPE F CURB

TYPE F CURB

NOTE: IRRIGATION COMPONENTS MAY BE
OUTSIDE OF MEDIAN AND CENTERLINE O

C-11 CANAL

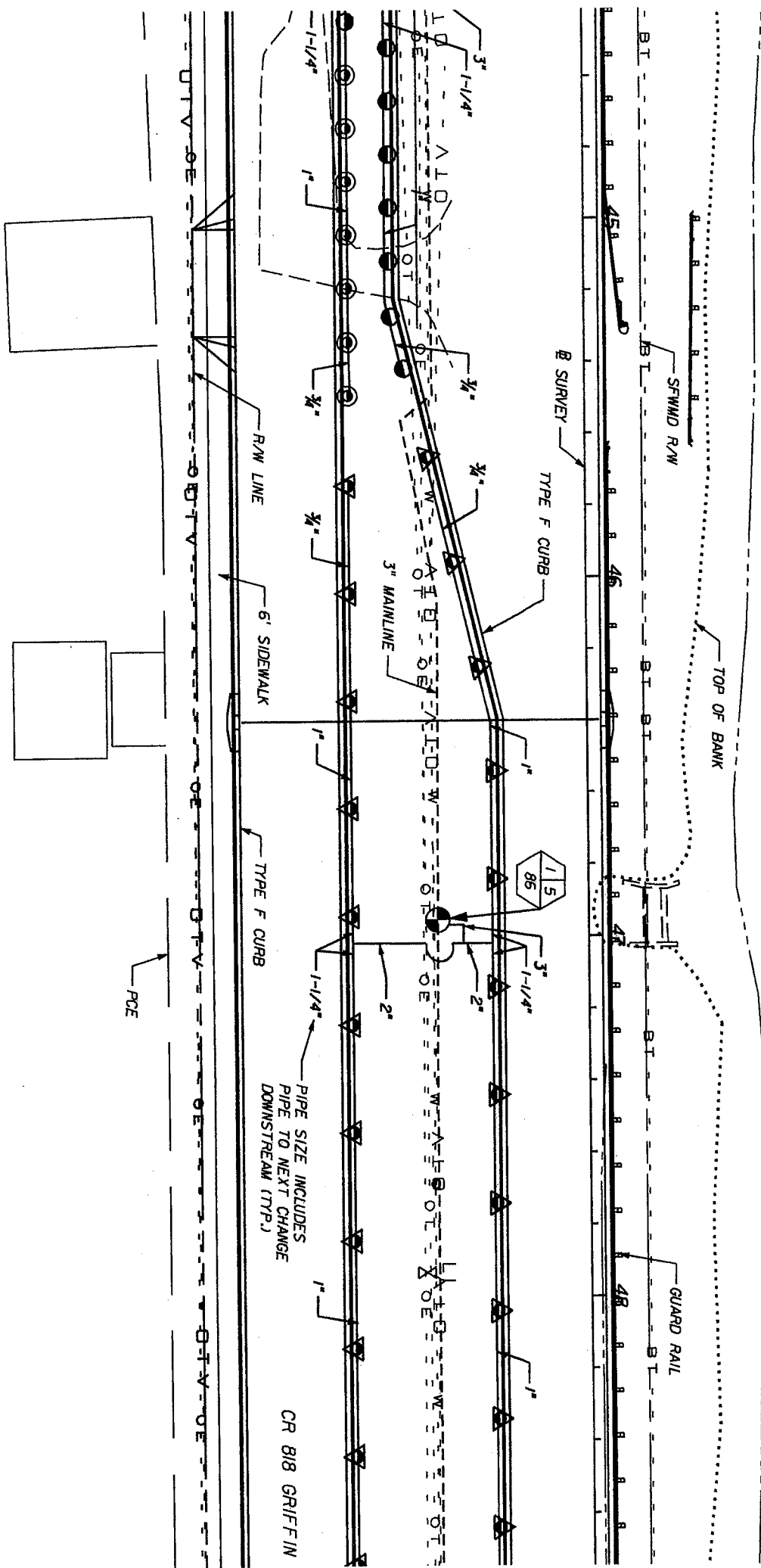

NOTE: IRRIGATION COMPONENTS MAY BE SHOWN OUT OF MEDIAN AND CENTERLINE OF CONSTRUCTION IS SHOWN (TYPICAL FOR ALL IRRIGATION SHEETS) FOR PURPOSES OF CLARITY

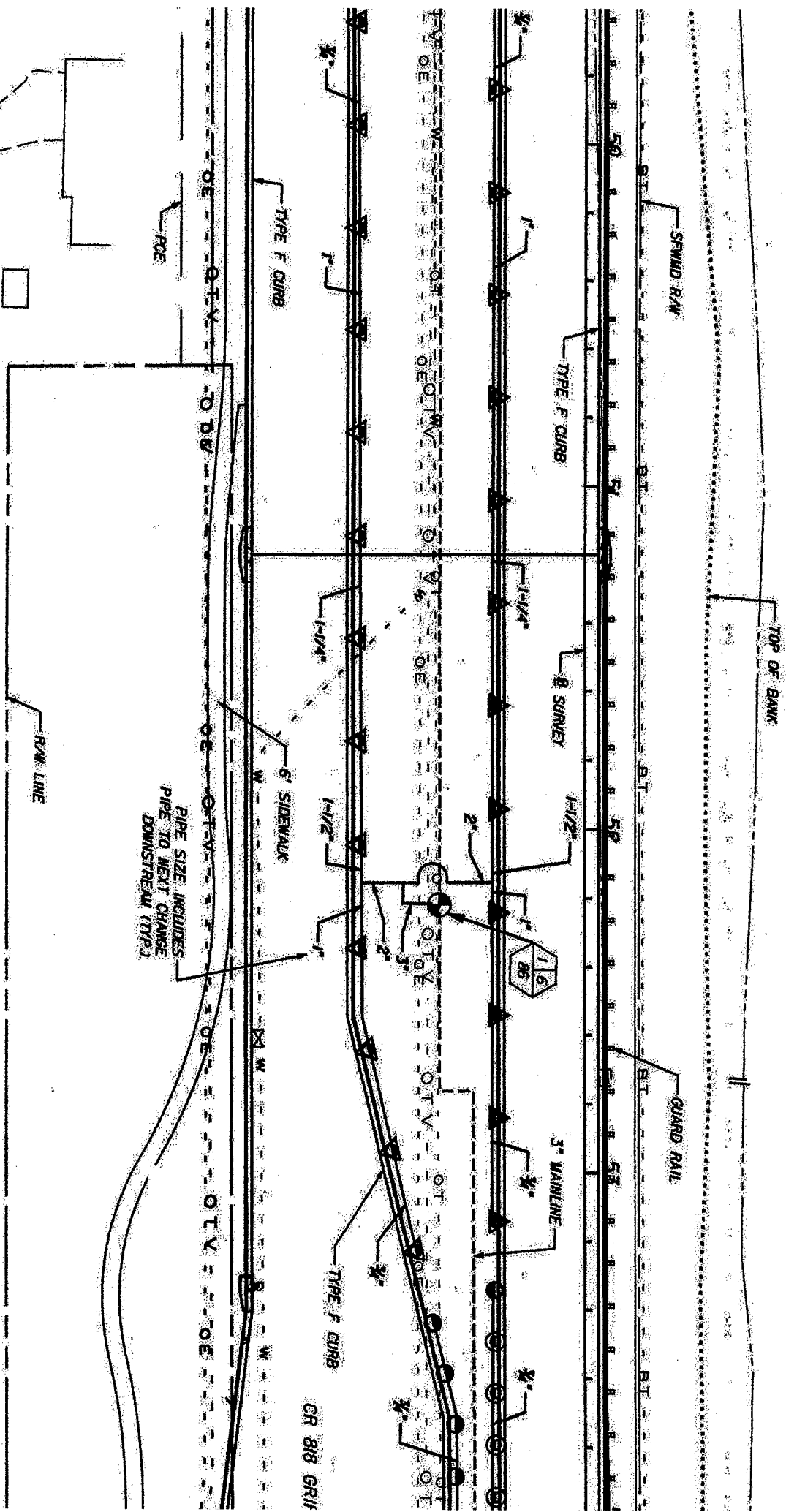

NOTE: IRRIGATION COMPONENTS MAY BE SHOWN OUTSIDE OF MEDIAN AND CENTERLINE OF CONSTRUCTION IS NOT SHOWN (TYPICAL FOR ALL IRRIGATION SHEETS) FOR PURPOSES OF CLARITY

OF MEDIAN AND CENTERLINE OF CONSTR
 SHOWN (TYPICAL FOR ALL IRRIGATION SHI
 PURPOSES OF CLARITY

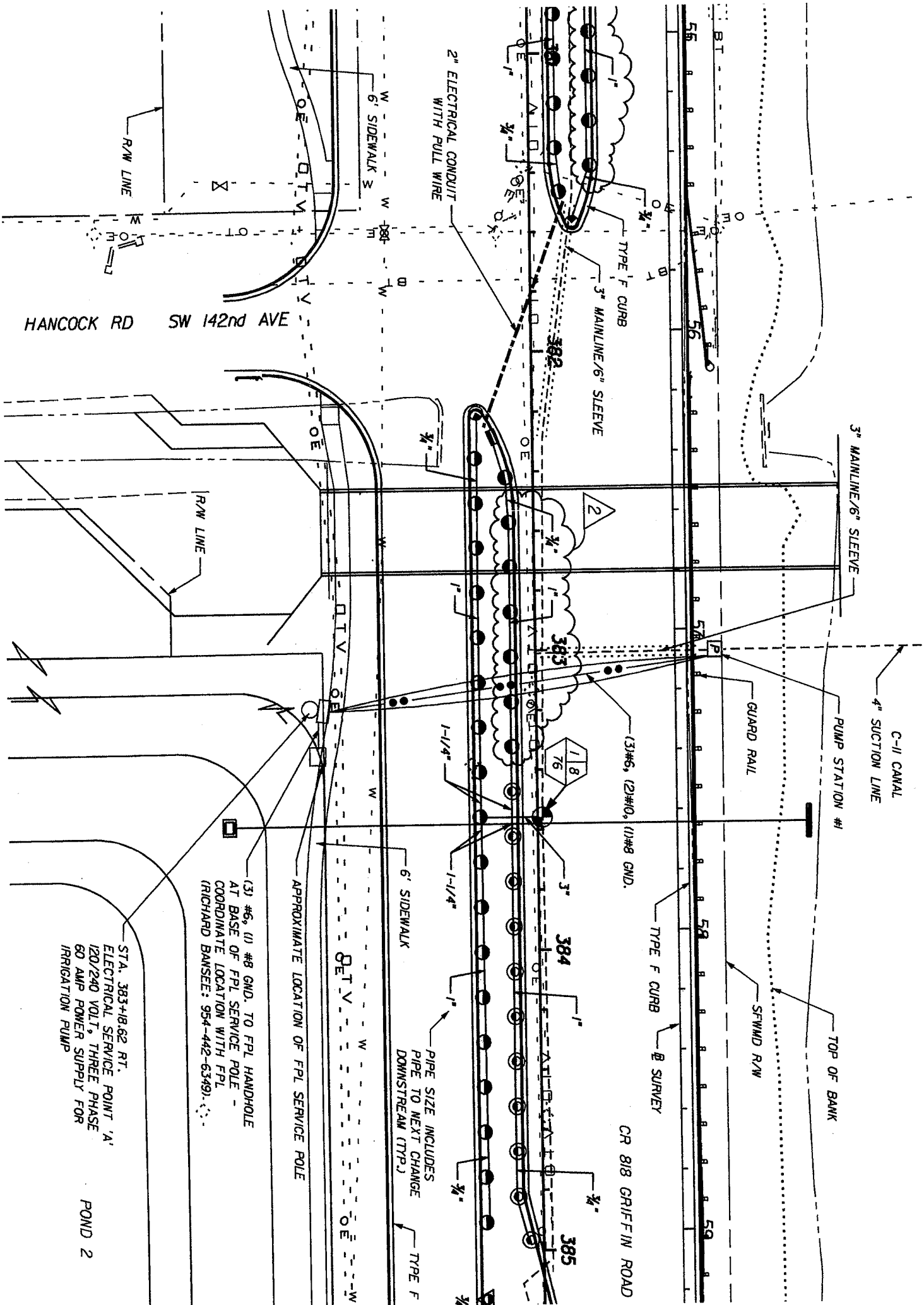

(3) #6, (1) #8 GND. TO FPL HANDHOLE
 AT BASE OF FPL SERVICE POLE -
 COORDINATE LOCATION WITH FPL
 (RICHARD BANSEE: 954-442-6349).

STA. 383+18.62 RT.
 ELECTRICAL SERVICE POINT 'A'
 120/240 VOLT, THREE PHASE
 80 AMP POWER SUPPLY FOR
 IRRIGATION PUMP

POND 2

PIPE SIZE INCLUDES
 PIPE TO NEXT CHANGE
 DOWNSTREAM (TTP.)

APPROXIMATE LOCATION OF FPL SERVICE POLE

CR 818 GRIFFIN ROAD

TOP OF BANK

SFWMD R/W

TYPE F CURB @ SURVEY

3" MAINLINE/6" SLEEVE

3" MAINLINE/6" SLEEVE

6' SIDEWALK

6' SIDEWALK

6' SIDEWALK

6' SIDEWALK

6' SIDEWALK

6' SIDEWALK

6' SIDEWALK

6' SIDEWALK

6' SIDEWALK

6' SIDEWALK

6' SIDEWALK

C-II CANAL

GUARD RAIL
TOP OF BANK

SPURD R/W

GUARD RAIL

TYPE F GURB

3" MAINLINE

8 SURVEY



PIPE SIZE INCLUDES
PIPE TO NEXT CHANGE
DOWNSTREAM (TYPE)

TYPE F GURB

CR BIB GRIFEN ROAD

6' SIDEWALK

R/W LINE



NOTE: IRRIGATION COMPONENTS MAY BE SHOWN
OF MEDIAN AND CENTERLINE OF CONSTRUCTION
SHOWN TYPICAL FOR ALL IRRIGATION SHEETS.

C-11 CANAL

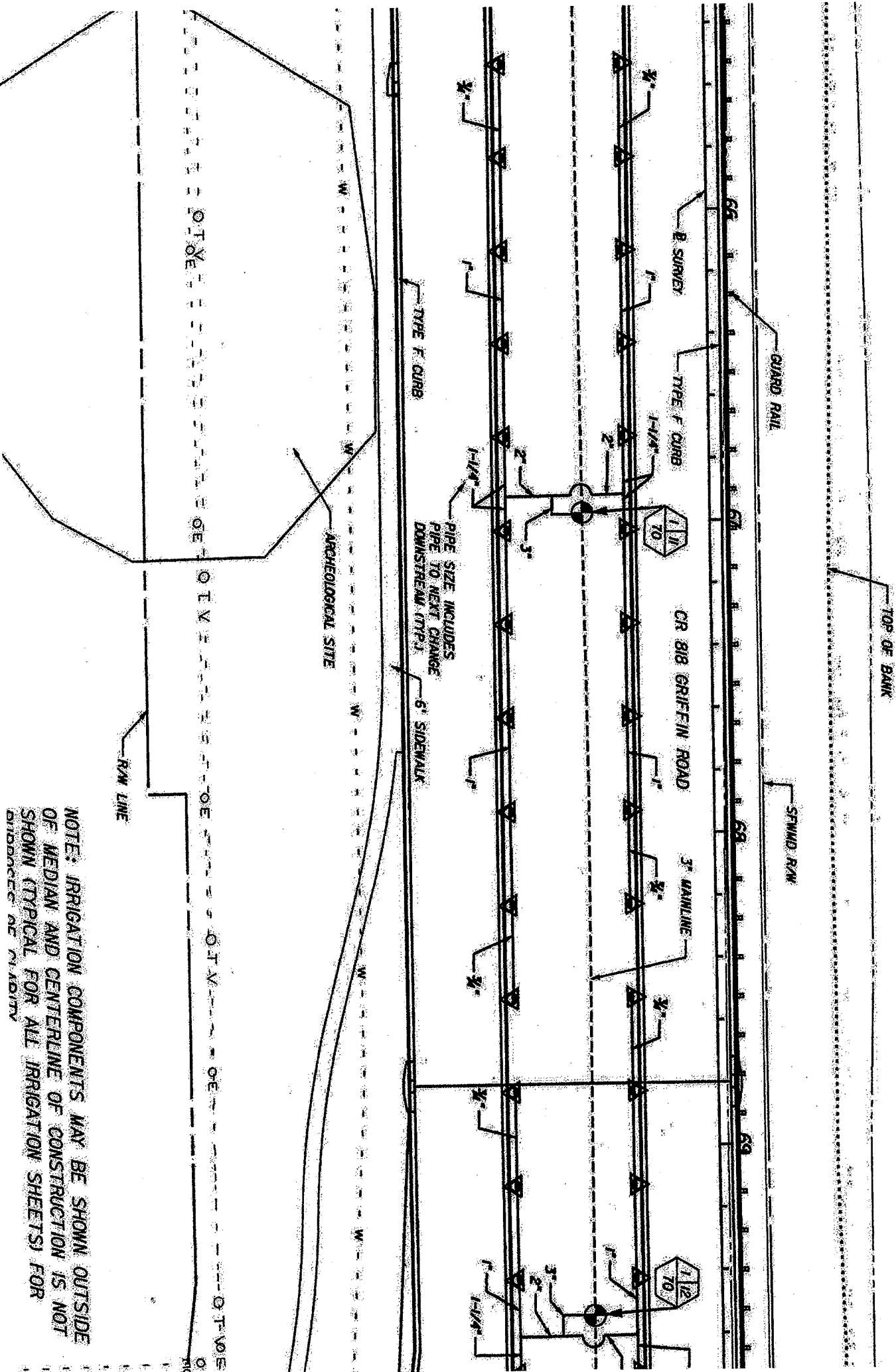

NOTE: IRRIGATION COMPONENTS MAY BE SHOWN OUTSIDE OF MEDIAN AND CENTERLINE OF CONSTRUCTION IS NOT SHOWN (TYPICAL FOR ALL IRRIGATION SHEETS) FOR BIDDING OF MAINTENANCE

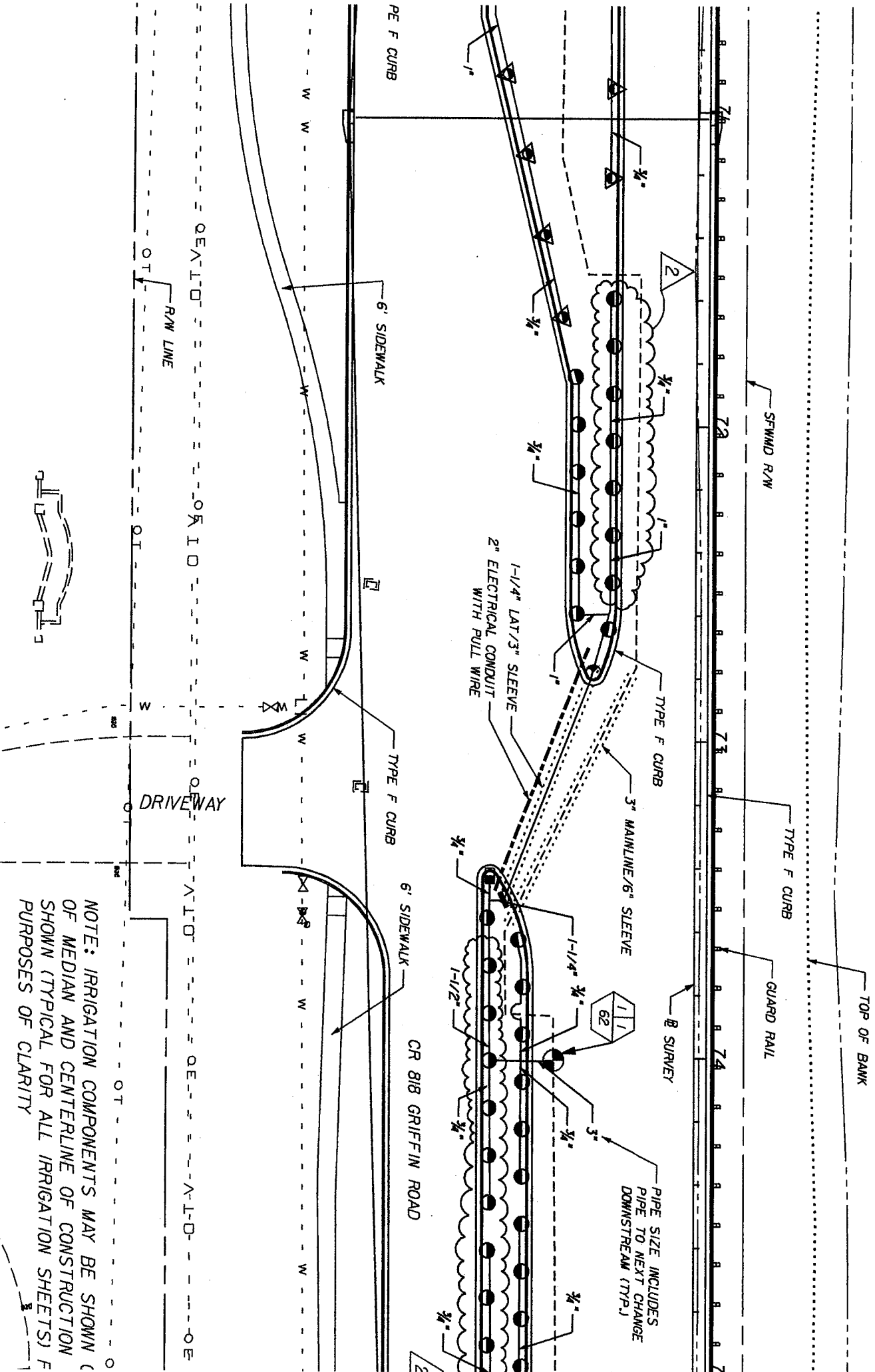

NOTE: IRRIGATION COMPONENTS MAY BE SHOWN (OF MEDIAN AND CENTERLINE OF CONSTRUCTION SHOWN (TYPICAL FOR ALL IRRIGATION SHEETS)) FOR PURPOSES OF CLARITY

C-11 CANAL

TOP OF BANK

GUARD RAIL

SFWMD R/W

8 SURVEY

TYPE F CURB

PIPE SIZE INCLUDES
PIPE TO NEXT CHANGE
DOWNSTREAM (TYP.)

F CURB

CR 818 GRIFFIN ROAD

TYPE F CURB

6' SIDEWALK

RAW LINE

ADDED

OE

ADDED

OE

NOTE: IRRIGATION COMPONENTS MAY BE SHOWN OUTS
OF MEDIAN AND CENTERLINE OF CONSTRUCTION IS N
CURRENT TYPICAL END ALL IRRIGATION CHECKS END

C-11 CANAL

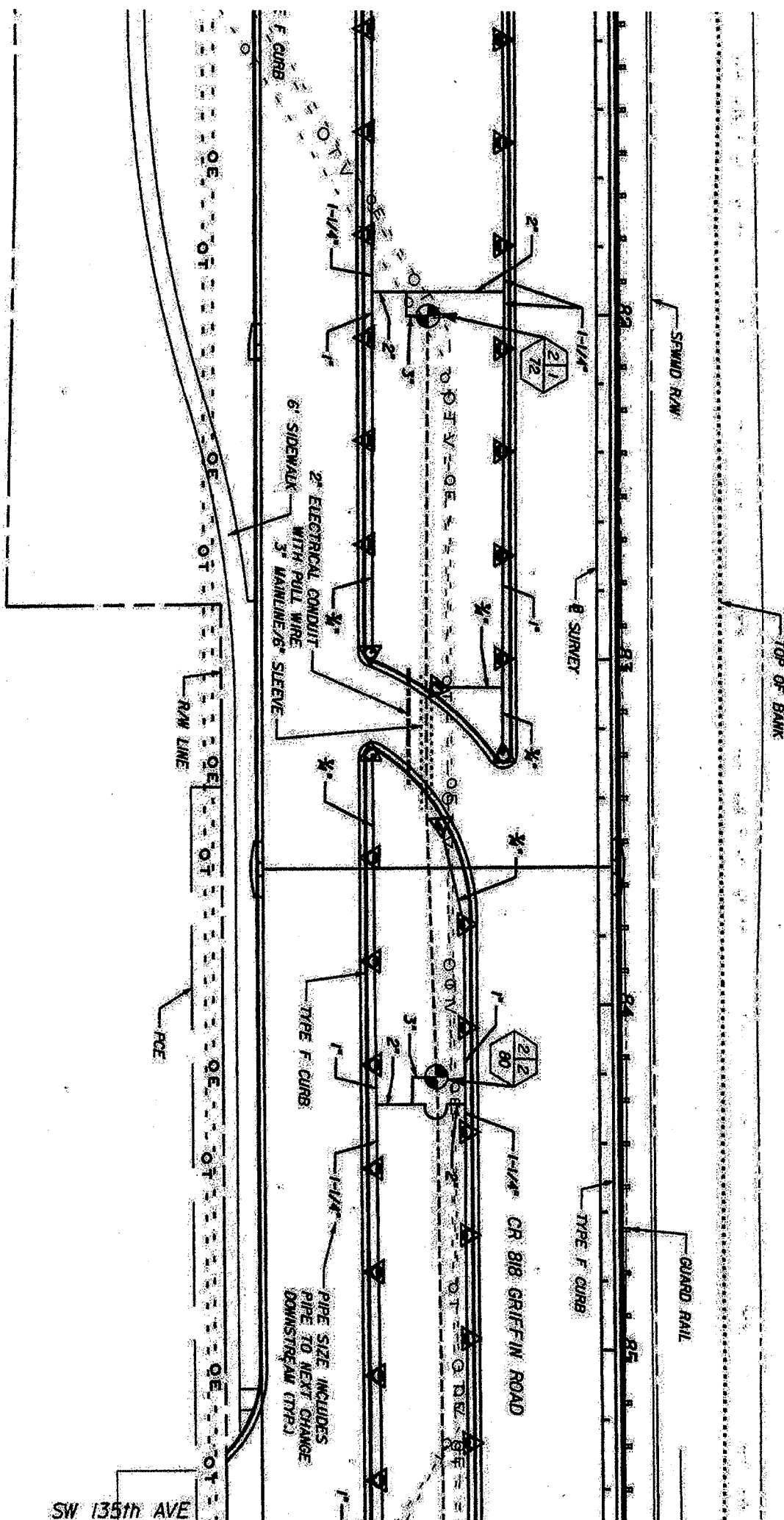

NOTE: IRRIGATION COMPONENTS MAY BE SHOWN OUTS OF MEDIAN AND CENTERLINE OF CONSTRUCTION IS N SHOWN (TYPICAL FOR ALL IRRIGATION SHEETS) FOR

LUPPO LANE SW 135th LANE

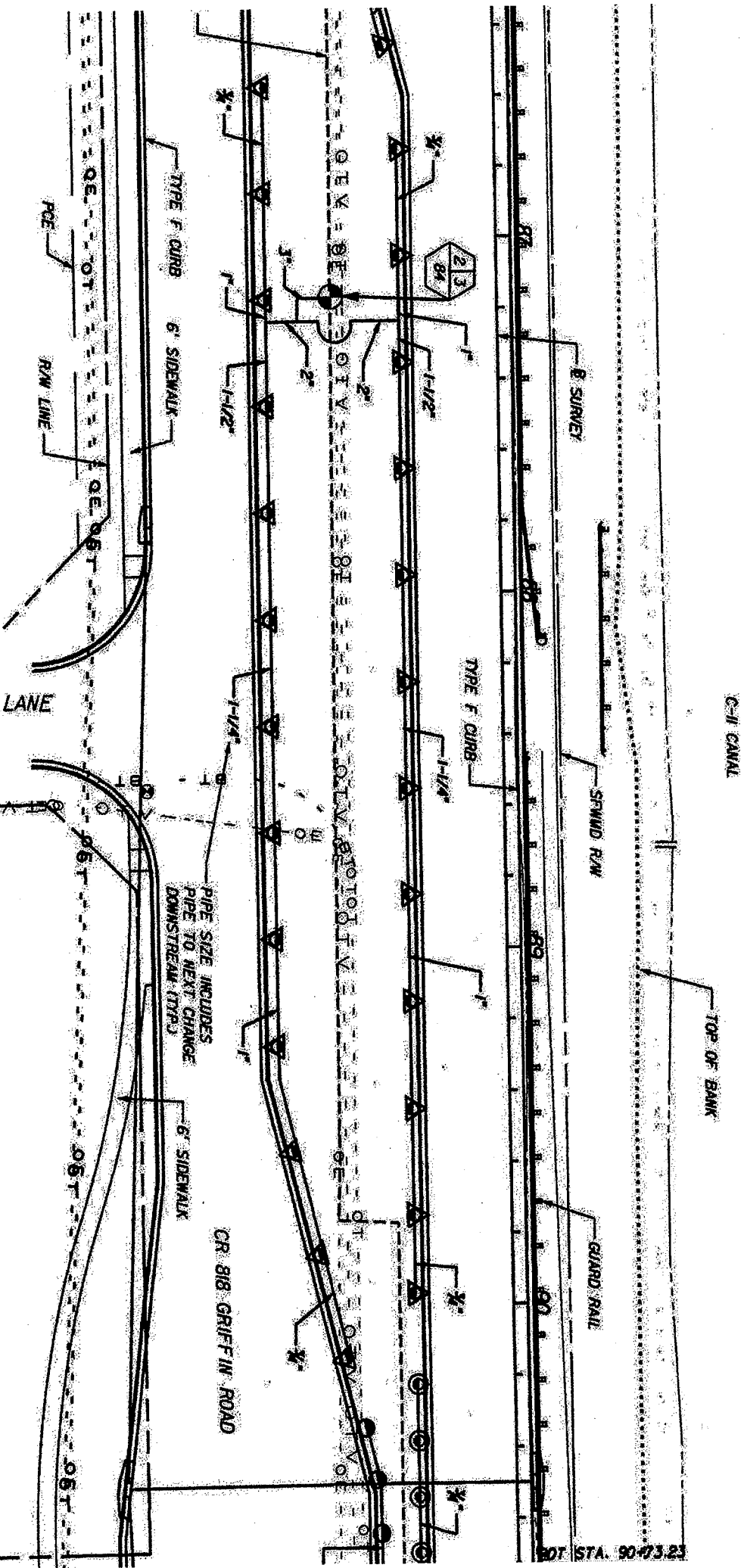

NOTE: IRRIGATION COMPONENTS MAY BE SHOWN
 OF MEDIAN AND CENTERLINE OF CONSTRUCTION
 SHOWN (TYPICAL FOR ALL IRRIGATION SHEETS)
 PURPOSES OF CLARITY

STATION 90+73.23

C-II CANAL

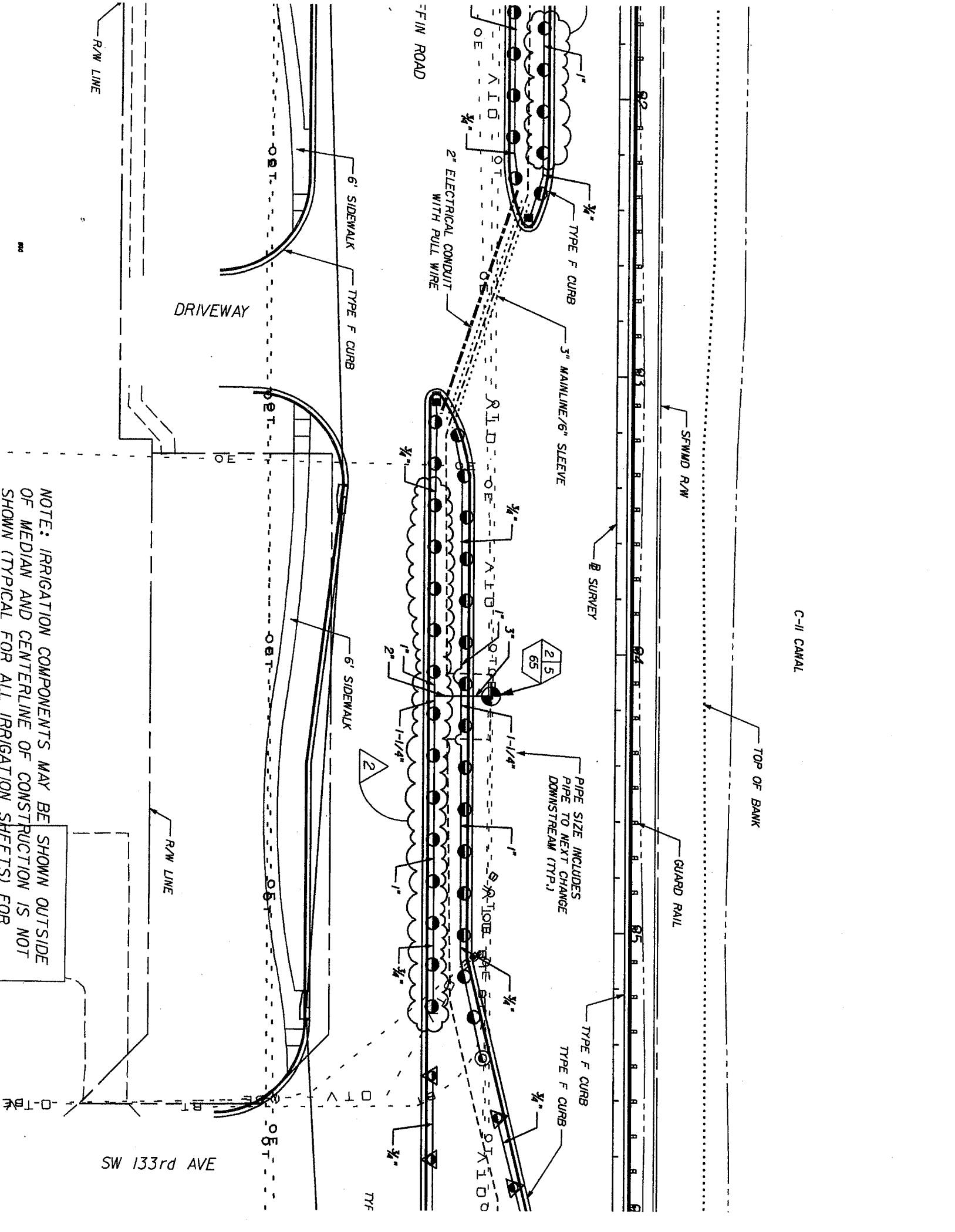

NOTE: IRRIGATION COMPONENTS MAY BE SHOWN OUTSIDE OF MEDIAN AND CENTERLINE OF CONSTRUCTION IS NOT SHOWN (TYPICAL FOR ALL IRRIGATION SHEETS) FOR

SW 133rd AVE

C-11 CANAL

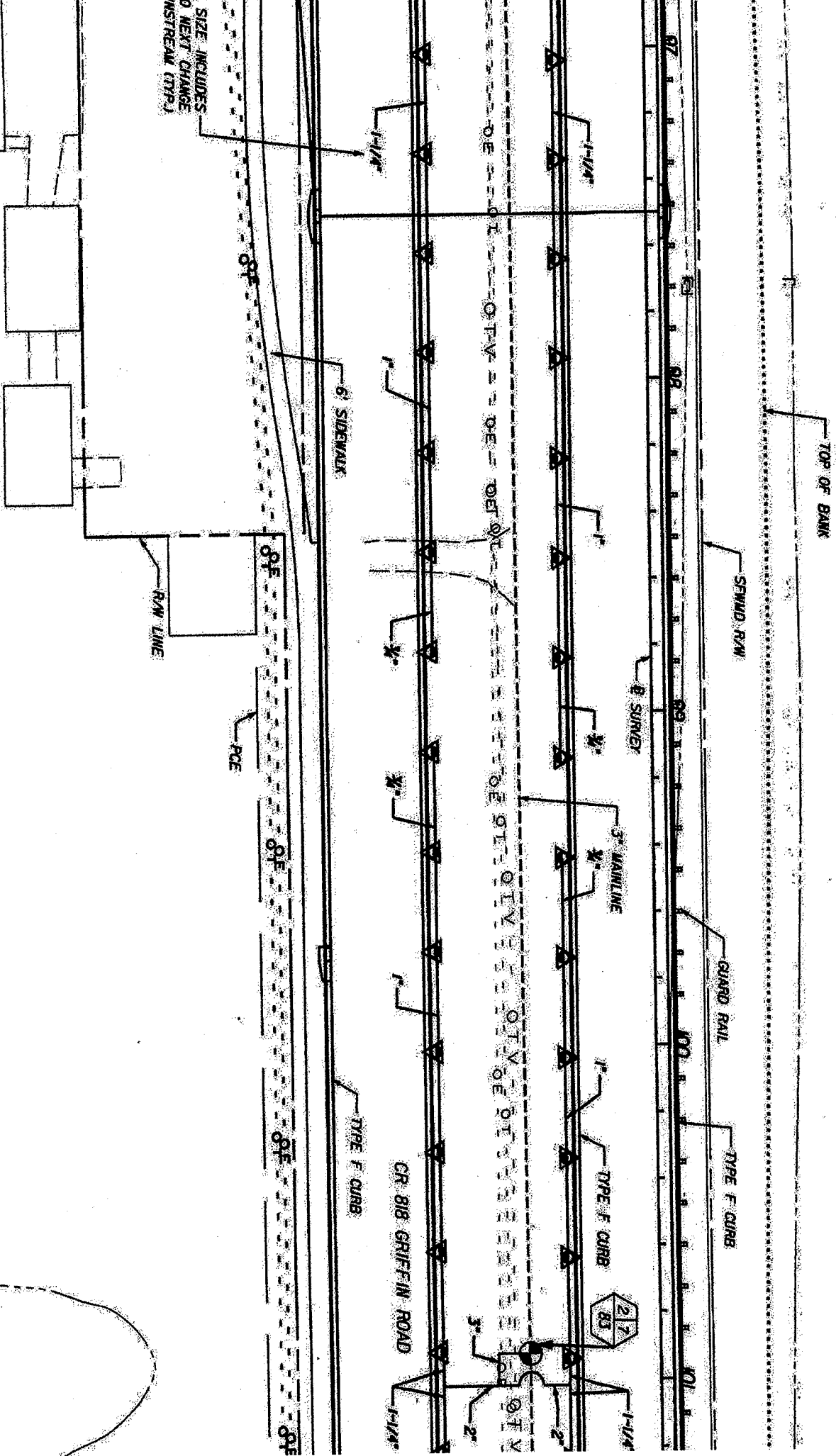

SIZE INCLUDES
 O NEXT CHANGE
 INSTRUMENT (TYP.)

6\"/>

R/W LINE

FCE

TYPE F CURB

CR 818 GRIFFIN ROAD

NOTE: IRRIGATION COMPONENTS MAY BE SHOWN OUTSIDE
 OF MEDIAN AND CENTERLINE OF CONSTRUCTION IS NOT
 SHOWN (TYPICAL FOR ALL IRRIGATION SHEETS) FOR
 PURPOSES OF CLARITY.

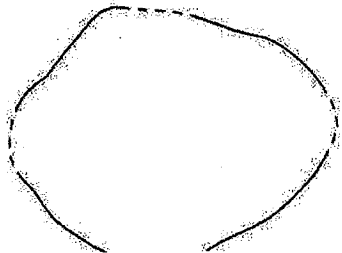

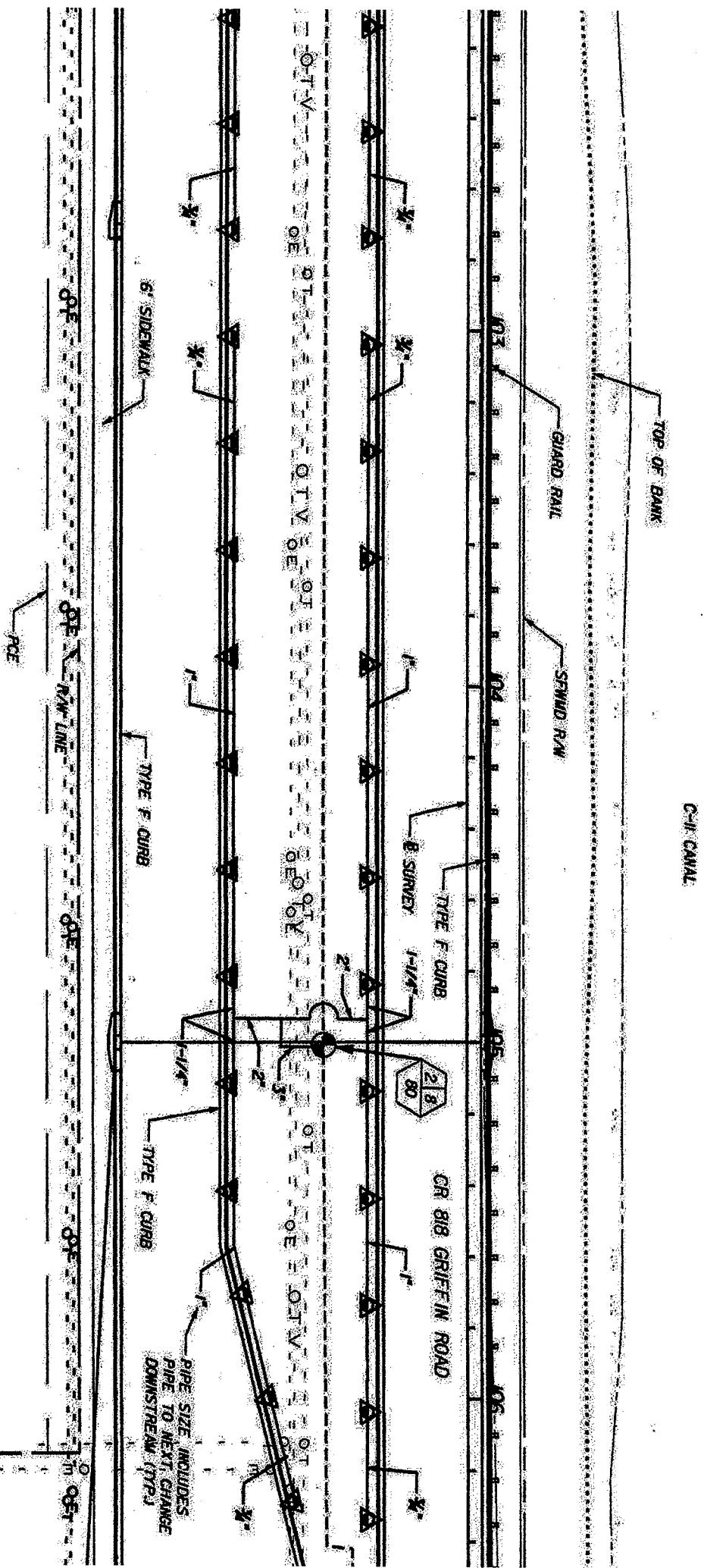

NOTE: IRRIGATION COMPONENTS MAY BE SHOWN OUTSIDE OF MEDIAN AND CENTERLINE OF CONSTRUCTION IS NOT SHOWN (TYPICAL FOR ALL IRRIGATION SHEETS) FOR PURPOSES OF CLARITY

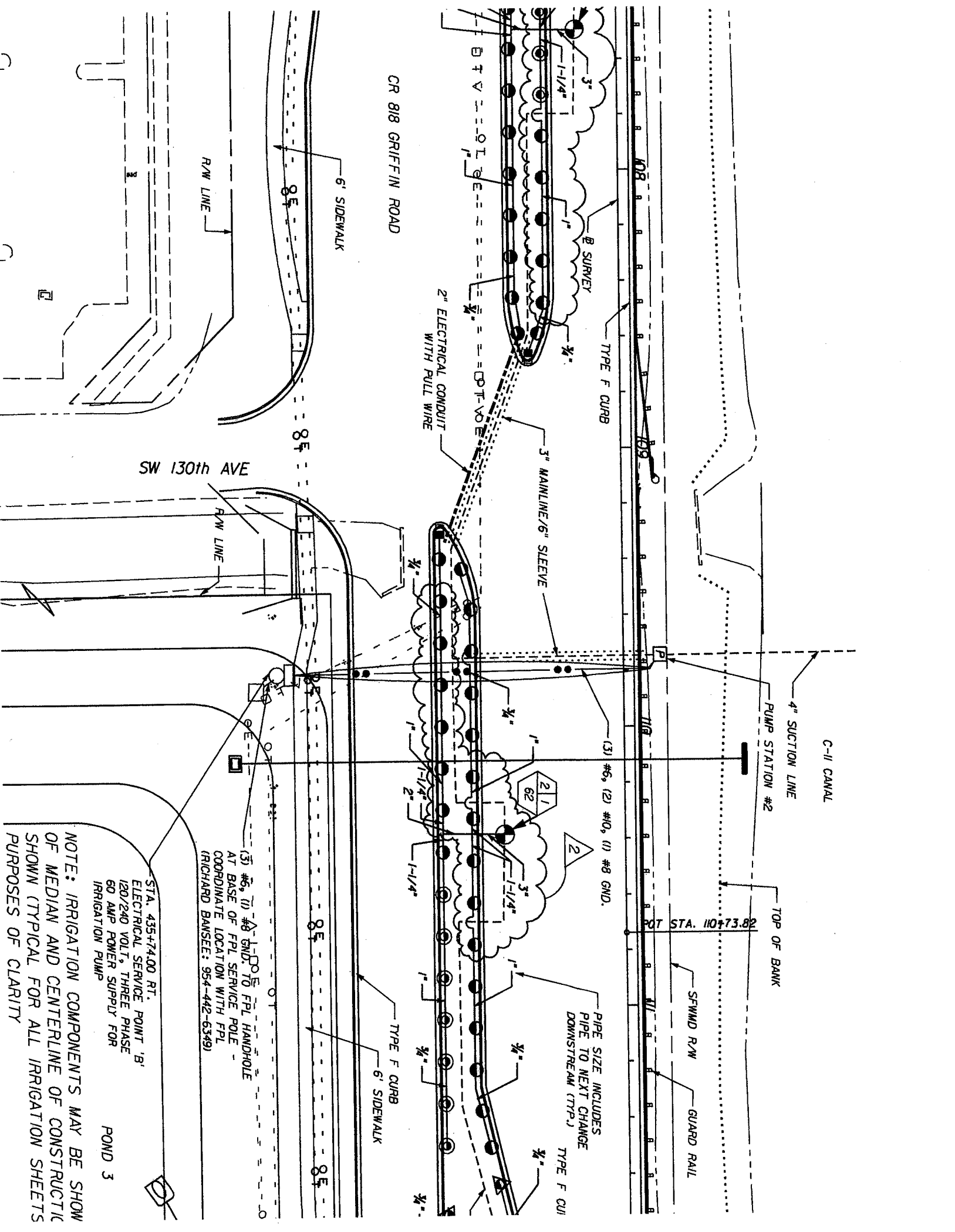

CR 818 GRIFFIN ROAD

SW 130th AVE

C-II CANAL

4" SUCTION LINE
PUMP STATION #2

TOP OF BANK

SFWD R/W

GUARD RAIL

POT STA. 110+73.82

(3) #6, (2) #10, (1) #8 GND.

PIPE SIZE INCLUDES
PIPE TO NEXT CHANGE
DOWNSTREAM (TYP.)

TYPE F CURB

2" ELECTRICAL CONDUIT
WITH PULL WIRE

3" MAINLINE/6" SLEEVE

TYPE F CURB

6' SIDEWALK

TYPE F CURB
6' SIDEWALK

STATIONING TO FPL HANDHOLE
AT BASE OF FPL SERVICE POLE
COORDINATE LOCATION WITH FPL
(RICHARD BANSEER: 954-442-6349)

STA. 435+74.00 RT.
ELECTRICAL SERVICE POINT 'B'
120/240 VOLT, THREE PHASE
60 AMP POWER SUPPLY FOR
IRRIGATION PUMP

POND 3

NOTE: IRRIGATION COMPONENTS MAY BE SHOW
OF MEDIAN AND CENTERLINE OF CONSTRUCTIC
SHOWN (TYPICAL FOR ALL IRRIGATION SHEETS
PURPOSES OF CLARITY

C-II CANAL

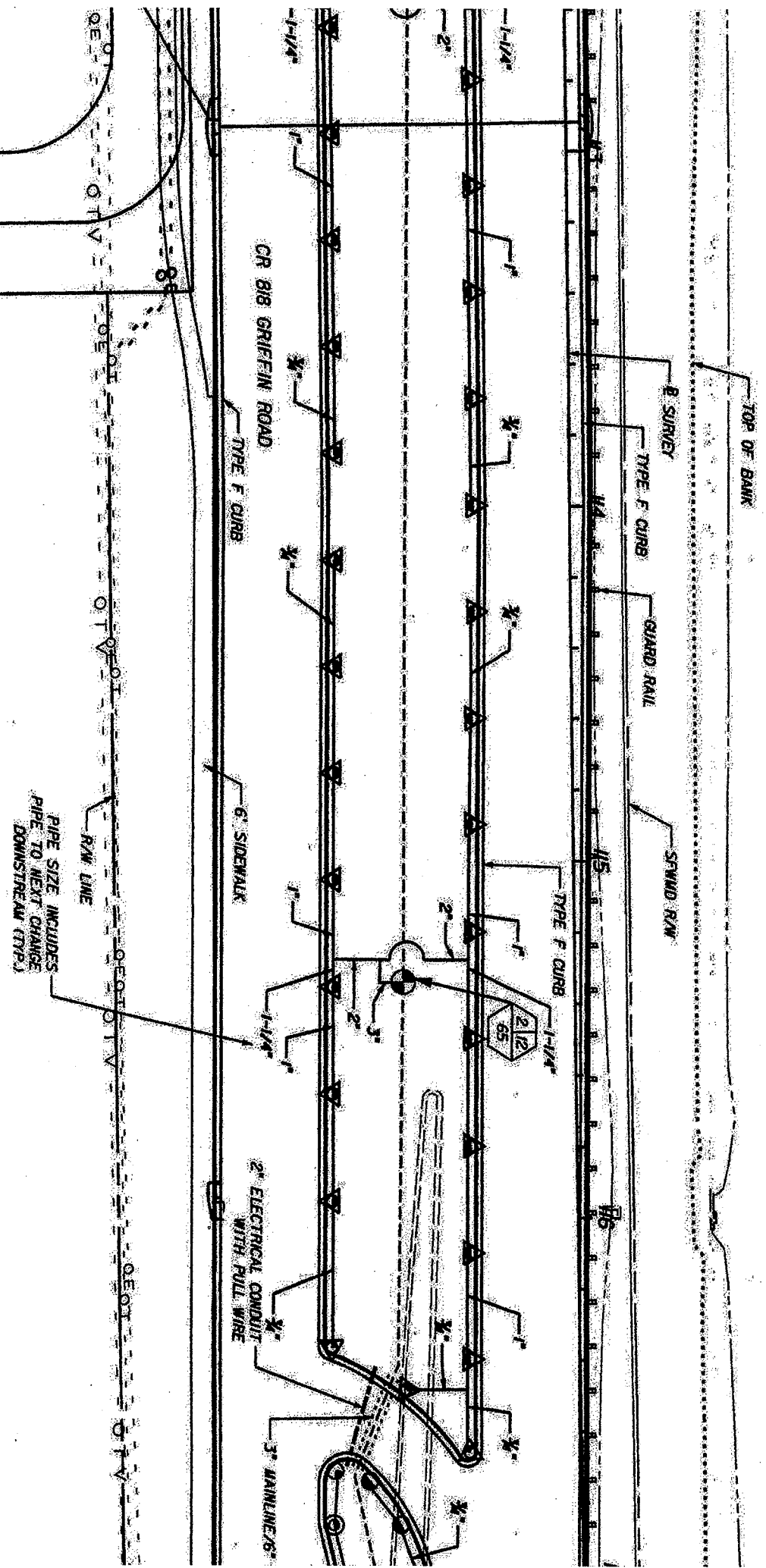

NOTE: IRRIGATION COMPONENTS MAY OF MEDIAN AND CENTERLINE OF CO. SHOWN (TYPICAL FOR ALL IRRIGATION PURPOSES OF CLARITY

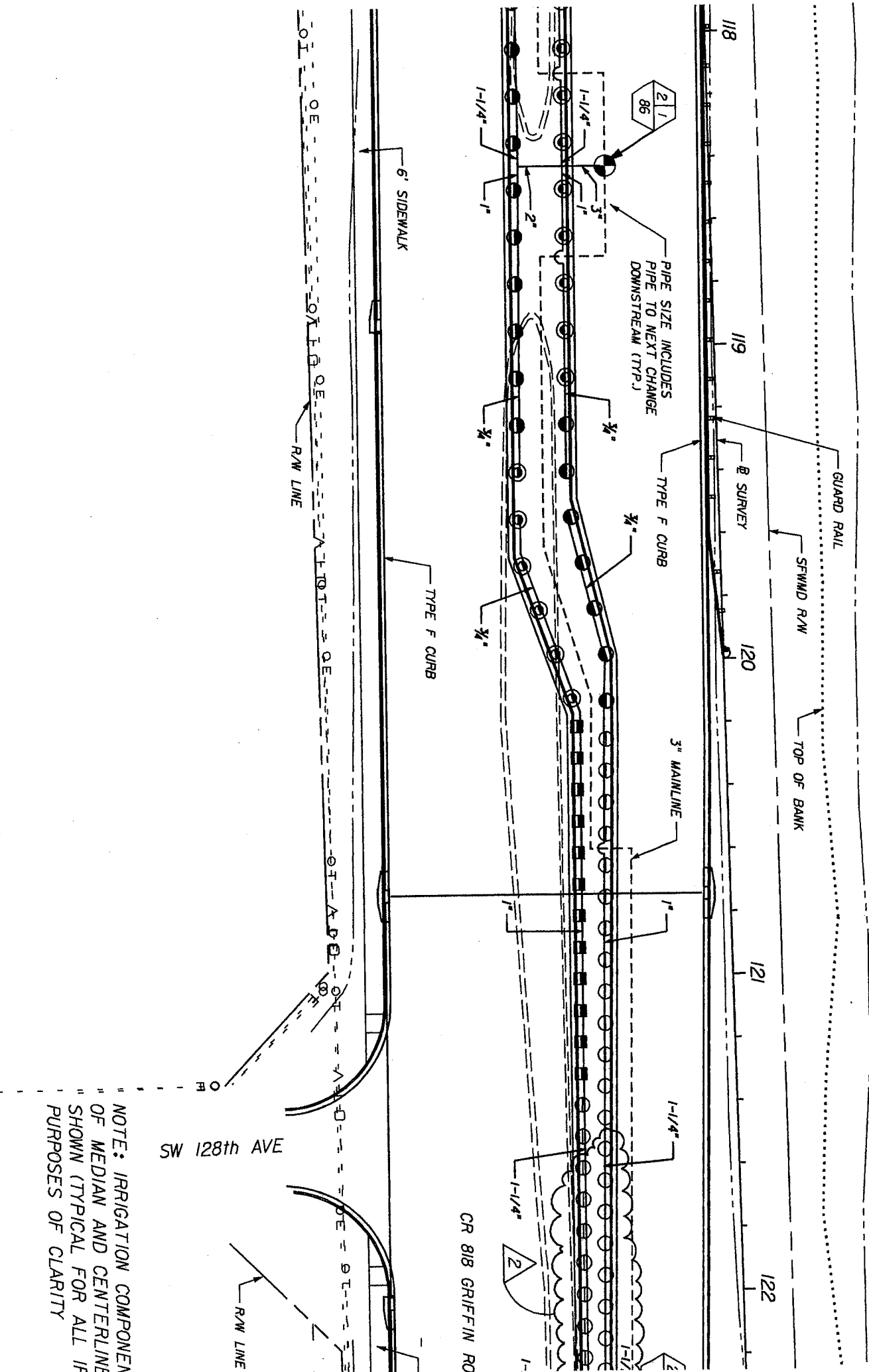

NOTE: IRRIGATION COMPONENT OF MEDIAN AND CENTERLINE SHOWN (TYPICAL FOR ALL IR PURPOSES OF CLARITY

C-II CANAL

C-II CANAL

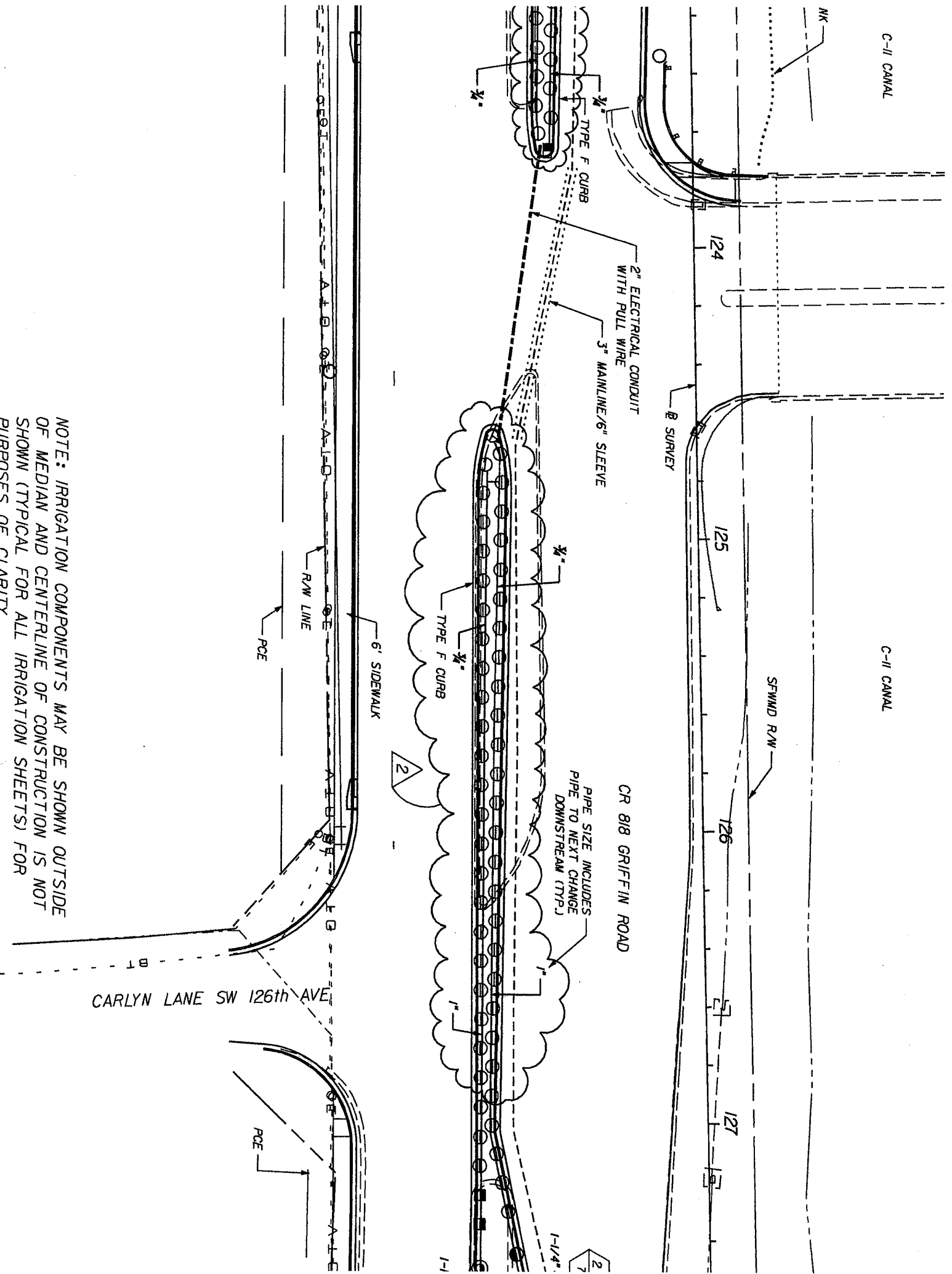

NOTE: IRRIGATION COMPONENTS MAY BE SHOWN OUTSIDE OF MEDIAN AND CENTERLINE OF CONSTRUCTION IS NOT SHOWN (TYPICAL FOR ALL IRRIGATION SHEETS) FOR PURPOSES OF CLARITY

C-11 CANAL

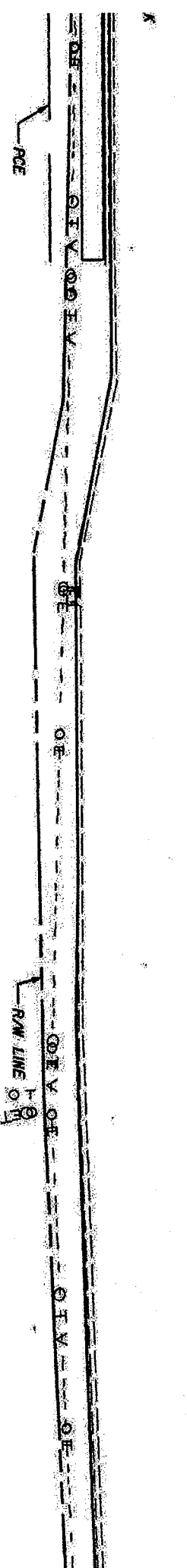
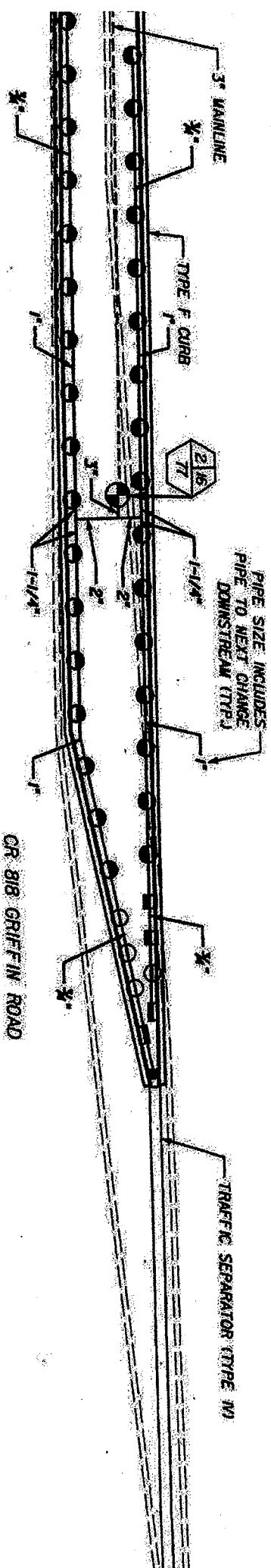
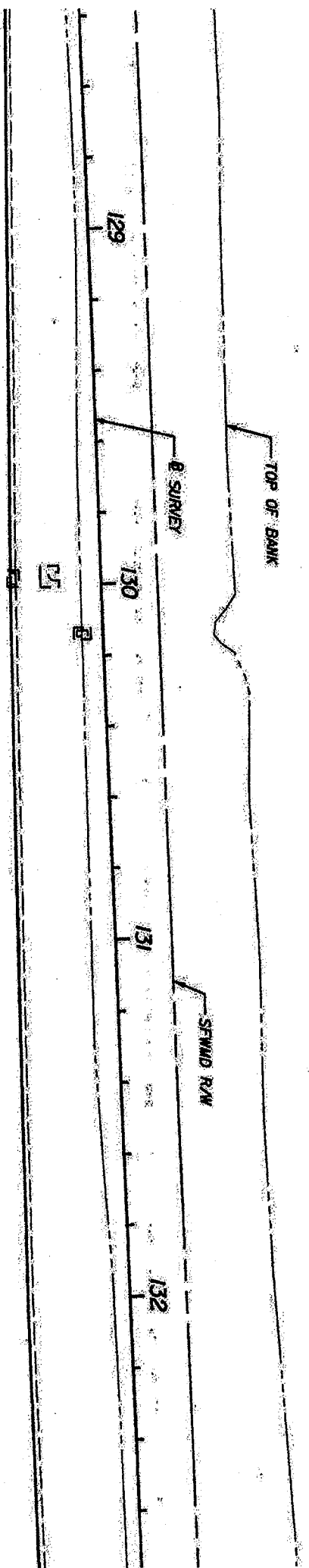

OR 818 GRIFFIN ROAD

NOTE: IRRIGATION COMPONENTS OF MEDIAN AND CENTERLINE OF SHOWN (TYPICAL FOR ALL IRRIGATION PURPOSES OF CLARITY

C-II CANAL

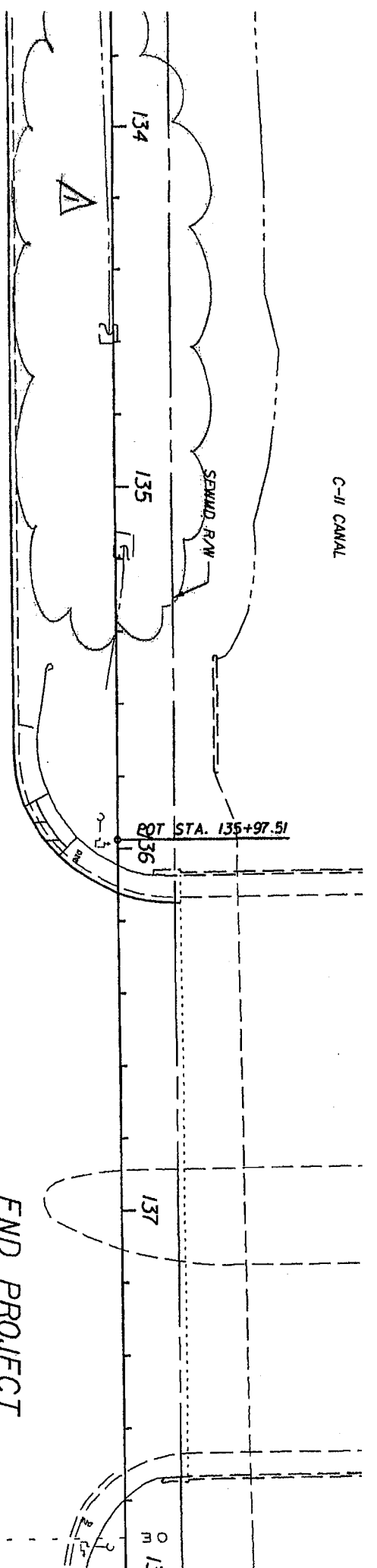

TRAFFIC SEPARATOR (TYPE M)



CR 818 GRIFFIN ROAD

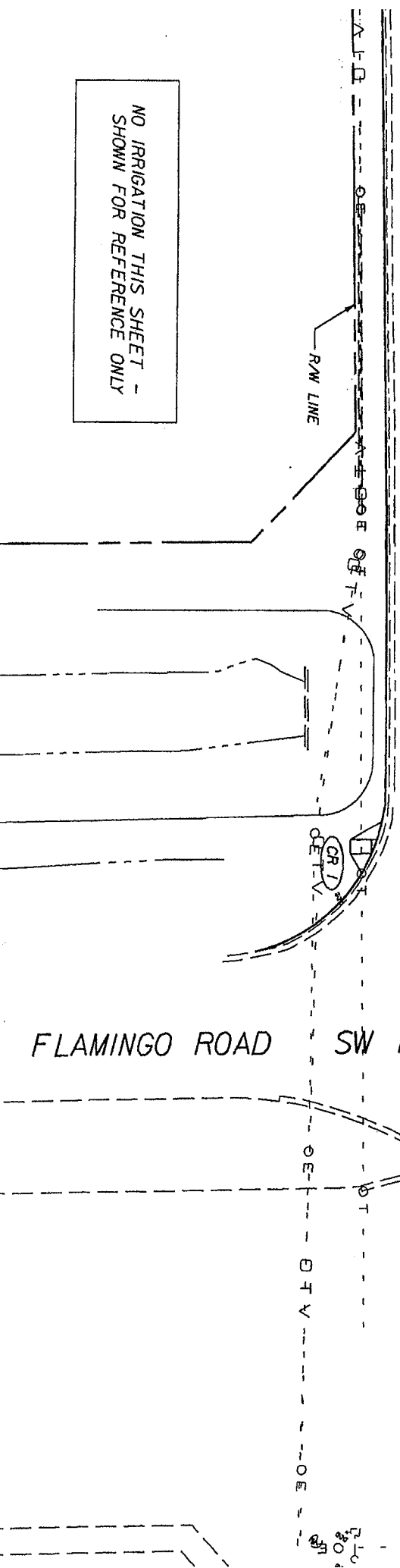

FLAMINGO ROAD SW 124TH AVE

NO IRRIGATION THIS SHEET - SHOWN FOR REFERENCE ONLY

END PROJECT
END IRRIGATION
STA 462+00

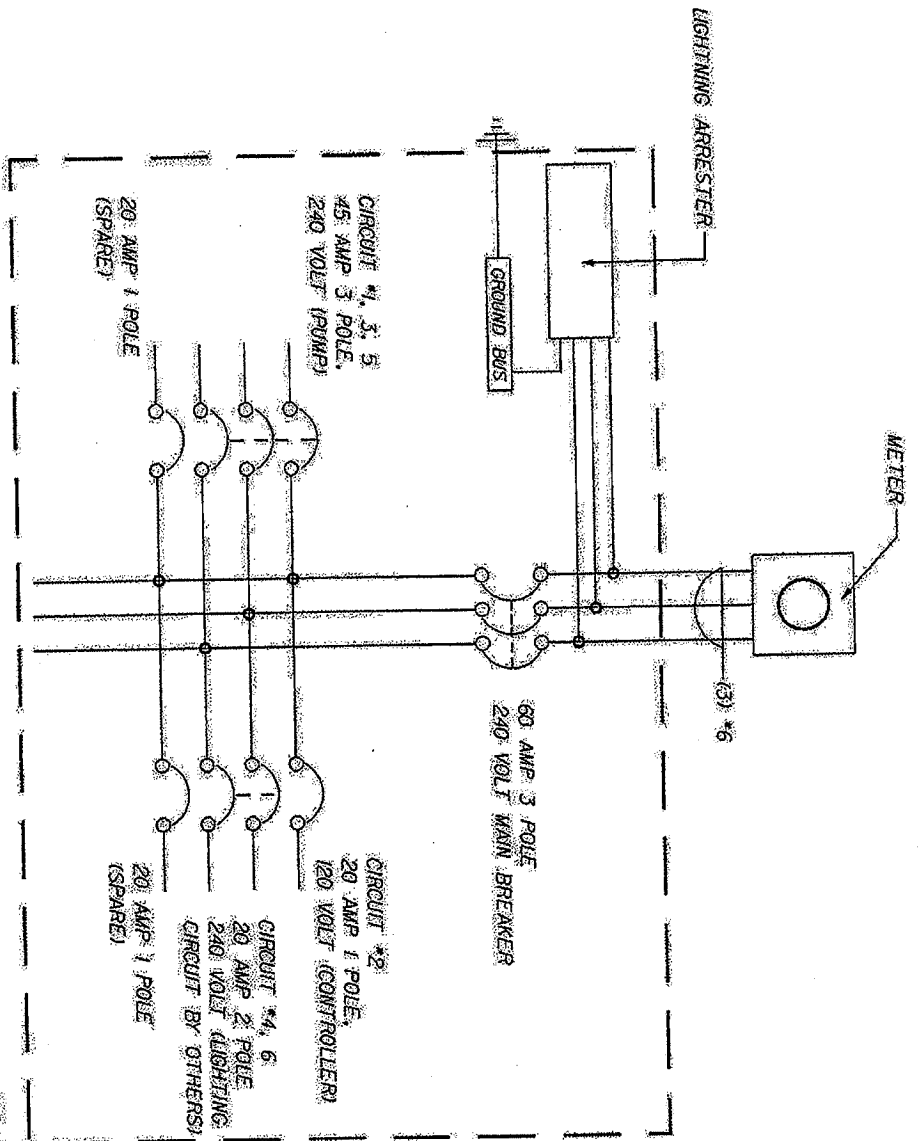

NOTE: COORDINATE ELECTRICAL SERVICE REQUIREMENTS WITH FLORIDA POWER AND LIGHT REPRESENTATIVE
 RICHARD BANSEE 3054-442-6349

**IRRIGATION ELECTRICAL SERVICE POINT WIRING DIAGRAM
 (TYPICAL FOR PUMP STATIONS A & B)**

NOT TO SCALE

TOWN OF SOUTHWEST RANCHES



REQUEST FOR PROPOSALS

Town-Wide Irrigation Maintenance Services

RFP No. 14-012

Date: September 17, 2014

TOWN OF SOUTHWEST RANCHES, FLORIDA
TOWN-WIDE IRRIGATION MAINTENANCE SERVICES

PROPOSAL FORMS

**MAINTENANCE PROPOSAL: PRICE LIST BY ZONE / SERVICE CATEGORY
(BASE PROPOSAL):**

IRRIGATION MAINTENANCE - ROADS

Service Category	Location / Zone #	Location / Zone Name	Unit Price per service	Annual Price - (Frequencies as per "Maintenance Frequencies" sheet)
A	1	GRIFFIN ROAD EAST ROW: Flamingo Rd. to SW 148 Ave. a.) Medians - All b.) 3 Retention Ponds c.) South swale - All from edge of pavement to property line	\$ 565.	\$ 6,780.
A	2	GRIFFIN ROAD WEST ROW: west of Dykes Rd. to east of SW 188 Ave.: c.) Medians - All d.) South swale - All	\$ 1235.	\$ 14,820.
SUBTOTAL IRRIGATION MAINTENANCE - ROADS			\$	21,600.

**MAINTENANCE PROPOSAL: PRICE LIST BY ZONE / SERVICE CATEGORY
(BASE PROPOSAL):**

IRRIGATION MAINTENANCE - PARKS AND OTHER FACILITIES

Service Category	Location / Zone #	Location Name	Unit Price per service	Annual Price - (Frequencies as per "Maintenance Frequencies" sheets)
D	33	Sunshine Ranches Equestrian Park - 20 acres	\$ 625.	\$ 7,500.
D	38	Town Hall - <2 acres	\$ 125.	\$ 1,500.
SUBTOTAL IRRIGATION MAINTENANCE - PARKS AND OTHER FACILITIES			\$	9,000.

GRAND TOTAL - IRRIGATION MAINTENANCE PROPOSAL: PRICE LIST BY ZONE (BASE PROPOSAL):

\$ 30,600.

*All counts/frequencies are approximate. The Town reserves the right to add or delete the quantity/frequency of service.

PROPOSER'S SIGNATURE: _____

COMPANY NAME: RESOLVE PROPERTY MAINTENANCE INC.

**TOWN OF SOUTHWEST RANCHES, FLORIDA
TOWN-WIDE IRRIGATION MAINTENANCE SERVICES**

MAINTENANCE PROPOSAL: PRICE LIST BY SERVICE (AUXILIARY SERVICES)

Item No.	Services	Unit	Unit Price
1	Irrigation Supervisor	Per hour 8:00 a.m. - 4:30 p.m., Mon-Fri =	\$ 75.
		Per hour for all other times =	\$ 120.
2	Irrigation Technician	Per hour 8:00 a.m. - 4:30 p.m., Mon-Fri =	\$ 55.
		Per hour for all other times =	\$ 85.
3	Irrigation Laborer	Per hour 8:00 a.m. - 4:30 p.m., Mon-Fri =	\$ 40.
		Per hour for all other times =	\$ 65.

IRRIGATION SYSTEM COMPONENTS (FURNISH AND INSTALL):

Item No.	Service	Unit	Unit Price
4	Rainbird 6" Pop UP	Each	\$ 15.
5	Corresponding Rainbird 6" nozzles as per plans/specs	Each	\$ 2.25
6	Rainbird 12" Pop UP	Each	\$ 18.
7	Corresponding Rainbird 12" nozzles as per plans/specs	Each	\$ 2.25
8	Rainbird 1800 series- (06 -12)	Each	\$ 22.
9	Corresponding 1800 series nozzles as per plans/specs	Each	\$ 2.50
10	Rainbird 5000 series - Rotor heads	Each	\$ 20.
11	Corresponding 5000 series nozzles as per plans/specs	Each	\$ 2.50
12	Rainbird 7005 series - Rotor heads	Each	\$ 87.50 DISCONTINUED
13	Corresponding 7005 series nozzles as per plans/specs	Each	\$ 3. " "
14	Rainbird 8005 series - Rotor heads	Each	\$ 85.
15	Corresponding 8005 series nozzles as per plans/specs	Each	\$ 3.50
16	Rainbird Talon series - Rotor heads	Each	\$ 90 DISCONTINUED
17	Corresponding Talon series nozzles as per plans/specs	Each	\$ 3.50 " "
18	Ell	Each	\$ 2.85
19	Funny pipe	Per Foot	\$ 2.95
20	NDS 10" Round valve box	Each	\$ 57.
21	NDS 12" X 17" Rectangular valve box	Each	\$ 75.
22	Amtech 12" X 18" Rectangular valve box	Each	\$ 85.
23	Rainbird 300 BPE Electric Remote Control Valves	Each	\$ 495.
24	Rainbird PGA series 2" Electric Remote Control Valves	Each	\$ 275.
25	Rainbird 5LRC 5 1/2" quick coupling Valves	Each	\$ 185.
26	Rainbird PEBPRS-D "Control Valve"	Each	\$ 275.
27	Rainbird 200 series Electric Remote Control Valve	Each	\$ 275.
28	Rainbird PRS Dial pressure regulating device	Each	\$ 65.

*All counts/frequencies are approximate. The Town reserves the right to add or delete the quantity/frequency of service.

PROPOSER'S SIGNATURE:

COMPANY NAME:

[Handwritten Signature]
RESERVE PROPERTY MAINTENANCE INC.

TOWN OF SOUTHWEST RANCHES, FLORIDA
TOWN-WIDE IRRIGATION MAINTENANCE SERVICES

The Proposer offers the preceding completed Proposal Forms for providing all labor, services, materials equipment, etc., to perform Town-Wide Irrigation Maintenance Services in accordance with the specifications herein.

PROPOSER'S SIGNATURE: _____

PROPOSER'S NAME: _____

COMPANY NAME: _____

EMAIL ADDRESS: _____

[INTENTIONALLY LEFT BLANK]

BROWARD COUNTY LOCAL BUSINESS TAX RECEIPT

115 S. Andrews Ave., Rm. A-100, Ft. Lauderdale, FL 33301-1895 – 954-831-4000

VALID OCTOBER 1, 2014 THROUGH SEPTEMBER 30, 2015

DBA: PRESTIGE PROPERTY MANAGEMENT & MAINTENANCE INC
Business Name: PRESTIGE PROPERTY MANAGEMENT & MAINTENANCE INC

Receipt #: 324-165400
Business Type: LAWN MAINTENANCE/LANDSCAPE (LAWN MAINTENANCE)

Owner Name: PRESTIGE PROPERTY MANAGEMENT
Business Location: 3300 SW 46 AVE
 DAVIE

Business Opened: 04/01/1986
State/County/Cert/Reg:
Exemption Code:

Business Phone: 584-3465

Rooms Seats Employees Machines Professionals

6

For Vending Business Only						
Number of Machines:				Vending Type:		
Tax Amount	Transfer Fee	NSF Fee	Penalty	Prior Years	Collection Cost	Total Paid
81.00	0.00	0.00	0.00	0.00	0.00	81.00

THIS RECEIPT MUST BE POSTED CONSPICUOUSLY IN YOUR PLACE OF BUSINESS

**THIS BECOMES A TAX RECEIPT
 WHEN VALIDATED**

This tax is levied for the privilege of doing business within Broward County and is non-regulatory in nature. You must meet all County and/or Municipality planning and zoning requirements. This Business Tax Receipt must be transferred when the business is sold, business name has changed or you have moved the business location. This receipt does not indicate that the business is legal or that it is in compliance with State or local laws and regulations.

Mailing Address:

PRESTIGE PROPERTY MANAGEMENT
 3300 SW 46 AVE
 DAVIE, FL 33314

Receipt # 01A-13-00005327
Paid 07/15/2014 81.00

2014 - 2015



**TOWN OF DAVIE
BUSINESS TAX RECEIPT**

6591 SW 45th St
Davie, FL 33314

First-Class Mail
PRSRT
U S Postage Paid
PDS

Name and Location of Business Tax Receipt

**PRESTIGE PROPERTY MGMT & MAINT
3300 SW 46 AVE 1**

DAVIE, FL 33314

License Type: **Offices Desk Space No Stock**
Licensed For & Quantity: **Offices Desk Space No Stock 1**

License #:	7424	Phone #:	3055815675
Effective Date:	10/1/2014	Expiration Date:	9/30/2015
REFERENCE:	MAILING ADDRESS:		
	TO: PRESTIGE PROPERTY MGMT & MAINT 3300 SW 46 AVE #1		
Restrictions:	DAVIE FL 33314		

State of Florida

Department of State

I certify from the records of this office that PRESTIGE PROPERTY MAINTENANCE INC is a corporation organized under the laws of the State of Florida, filed on February 18, 1986.

The document number of this corporation is M27540.

I further certify that said corporation has paid all fees due this office through December 31, 2014, that its most recent annual report/uniform business report was filed on April 23, 2014, and its status is active.

I further certify that said corporation has not filed Articles of Dissolution.

*Given under my hand and the
Great Seal of the State of Florida
at Tallahassee, the Capital, this
the Twenty-first day of May, 2014*



Ken Datzner
Secretary of State

Authentication ID: CU0274431952

To authenticate this certificate, visit the following site, enter this ID, and then follow the instructions displayed.

<https://efile.sunbiz.org/certauthver.html>

BROWARD COUNTY FLORIDA

SPEC PLUMBER-LAWN SPRINKLER
LICA, FRED W. QUALIFYING
PRESTIGE PROPERTY MGT & MAINT, INC
3300 SW 46 AVE SUITE #6
DAVIE FL 333142215
EXPIRES 08/31/2015



CERTIFICATE OF COMPETENCY
Detach and SIGN the reverse side of this card IMMEDIATELY upon receipt! You should carry this card with you at all times.

Contractor must obtain a photo I.D. Certificate of Competency Card every two years.

LICA, FRED W.
5071 SW 64 AVE
DAVIE FL 33314

BROWARD COUNTY FLORIDA
CERTIFICATE OF COMPETENCY
LICA, FRED W. QUALIFYING
PRESTIGE PROPERTY MGT & MAINT, INC
3300 SW 46 AVE SUITE #6
DAVIE FL 333142215
EXPIRES 08/31/2015

CERTIFICATE OF COURSE COMPLETION
KNOW ~ THE ~ FLOW

This certificate is awarded to

Fred Lica

May 17, 2011

Jimmy Moore
Instructor

Ray De
Instructor

John Park
Instructor

Diana Shively
Instructor



www.sfwmd.gov

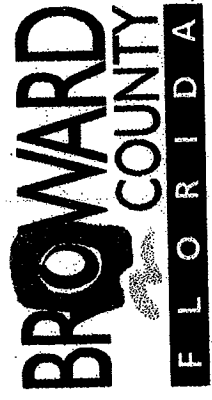



UF UNIVERSITY of
FLORIDA
IFAS Extension

Certificate of Training Best Management Practices Florida Green Industries

Certificate #
GV23846

Trainee ID #

The undersigned hereby acknowledges that

Fred W. Lica

has successfully met all requirements necessary to be fully trained through the Green Industries Best Management Practices Program developed by the Florida Department of Environmental Protection with the University of Florida Institute of Food and Agricultural Sciences.

Issuer

M. Orfanedes

Instructor

8/15/2013

Date of Class

DEP Program Administrator

Not valid without seal

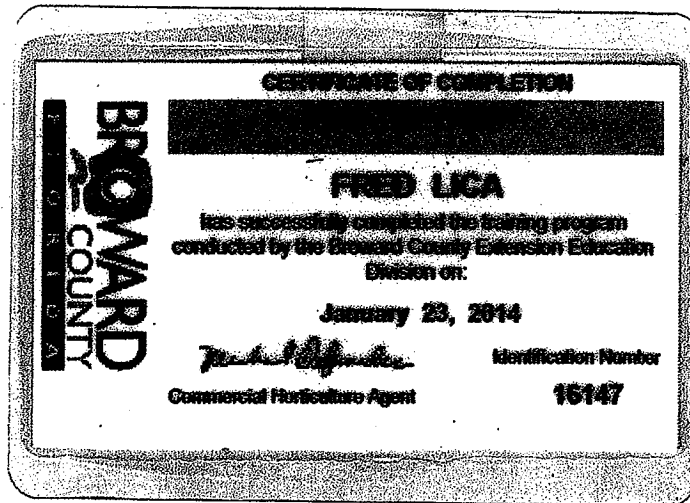

Fred Lica

From: Florida Irrigation Society [administration@fisstate.org]
Sent: Thursday, August 21, 2014 1:25 PM
To: Fred Lica
Subject: Florida Irrigation Society Payment receipt



Florida Irrigation Society

Managing Every Drop

Your payment has been received and processed. Please find your receipt below.

PAYMENT RECEIPT

PRESTIGE PROPERTY MAINTENANCE

Date: 21 Aug 2014
Amount: \$200.00
Tender: PayPal Payments Standard

Payment received from:
Fred Lica
fred@prestigepmm.com

Payment for:

Date	Document	
21 Aug 2014	Invoice 00658	Settled amount \$200.00
	Membership application. Level: E. Irrigation System Operator	Invoice total \$200.00
		Due \$0.00

Total settled: \$200.00
Available balance: \$0.00

Thank you for your support!



466 94th Avenue N. St. Petersburg, Florida 33702

phone: 727.209.1595

fax: 727.578.9982

email: administration@fisstate.org

8/21/2014

This is to Certify that

FRED LICA

has successfully completed the requirements outlined in the Rain Bird Academy Guide for:

49 -MAXICOM LEVEL 1 SOFTWARE

05/11/2012



Robert Pfeil, Manager, Training Services, Rain Bird Services Corporation

RAIN BIRD®

This is to Certify that

FRED LICA

has successfully completed the requirements outlined in the Rain Bird Academy Guide for:
46 - MAXICOM LEVEL 1 HARDWARE

05/09/2012



Robert Pfeil, Manager, Training Services, Rain Bird Services Corporation

RAIN BIRD®

The mission of the Florida Nursery, Growers & Landscape Association is to promote and protect the success and professionalism of our members.

PRESTIGE PROPERTY MAINTENANCE, INC.

is a member of the

Florida Nursery, Growers & Landscape Association

through June 30, 2015



Ben Bolusky, Executive Vice President



*Member in good
standing since 2010*

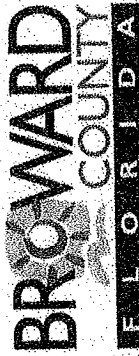

Governmental Center Annex
115 S. Andrews Avenue, Room A680 • Fort Lauderdale, Florida 33301 • 954-357-6400 • FAX 954-357-5674 • TTY 954-357-5664

Office of Economic and
Small Business Development

This Certificate is Awarded to:

**PRESTIGE PROPERTY MAINTENANCE, INC.
DBA PRESTIGE PROPERTY MANAGEMENT & MAINTENANCE, INC.**

As set forth in the Broward County Business Opportunity Act of 2012, the certification requirements have been met for.

Authorized Representative

County Business Enterprise

Anniversary Date: February 25th

The Office of Economic and Small Business Development must be notified within 30 days of any material changes in the business which may affect ownership and control. Failure to do so may result in the revocation of this certificate and/or imposition of other sanctions.

A service of the Broward County Board of County Commissioners
www.broward.org/smallbusiness

TOWN OF SOUTHWEST RANCHES, FLORIDA
TOWN-WIDE IRRIGATION MAINTENANCE SERVICES

DRUG FREE WORKPLACE

Proposers must certify that they will provide a drug-free workplace. Preference shall be given to businesses with drug-free workplace programs in accordance with the Town's Procurement Code. In order to have a drug-free workplace program, a business shall:

- 1 Publish a statement notifying employees that the unlawful manufacture, distribution, dispensing, possession, or use of a controlled substance is prohibited in the workplace and specifying the actions that will be taken against employees for violations of such prohibition.
- 2 Inform employees about the dangers of drug abuse in the workplace, the business's policy of maintaining a drug-free workplace, any available drug counseling, rehabilitation, and employee assistance programs, and the penalties that may be imposed upon employees for drug abuse violations.
- 3 Give each employee engaged in providing the commodities or contractual services that are under Proposal a copy of the statement specified in subsection (1).
- 4 In the statement specified in subsection (1), notify the employees that, as a condition of working on the commodities or contractual services that are under Proposal, the employee will abide by the terms of the statement and will notify the employer of any conviction of, or plea of guilty or nolo contendere to, any violation of chapter 893 or of any controlled substance law of the United States or any state, for a violation occurring in the workplace no later than five (5) days after such conviction.
- 5 Impose a sanction on, or require the satisfactory participation in a drug abuse assistance or rehabilitation program, if such is available in the employee's community, by any employee who is so convicted.
- 6 Make a good faith effort to continue to maintain a drug-free workplace through implementation of this section.

As the person authorized to sign the statement, I certify that this firm complies fully with the above requirements.

PROPOSER'S SIGNATURE: _____

COMPANY NAME: RESIDENT PROPERTY MAINTENANCE INC.

TOWN OF SOUTHWEST RANCHES, FLORIDA
TOWN-WIDE IRRIGATION MAINTENANCE SERVICES

SWORN STATEMENT PURSUANT TO SECTION 287.133(3)(a), FLORIDA STATUTES, ON PUBLIC ENTITY CRIMES

THIS FORM MUST BE SIGNED AND SWORN TO IN THE PRESENCE OF A NOTARY PUBLIC OR OTHER OFFICIAL AUTHORIZED TO ADMINISTER OATHS.

1. This sworn statement is submitted to Town of SW Ranches
By Greg Luca for Pressure Property Maint. Inc
whose business address is 3300 SW 46 Ave Davie FL 33314
and (if applicable) its Federal Employer Identification Number (FEIN) is 59-2639529

(IF the entity has no FEIN, include the Social Security Number of the individual signing this sworn statement: _____)

2. I understand that a "public entity crime" as defined in Paragraph 287.133(1)(g), Florida Statutes, means a violation of any state or federal law by a person with respect to and directly related to the transaction of business with any public entity or with an agency or political subdivision of any other state or with the United States, including, but not limited to, any Proposal or contract for goods or services to be provided to any public entity or an agency or political subdivision of any other state of the United States and involving antitrust, fraud, theft, bribery, collusion, racketeering, conspiracy, or material misrepresentation.
3. I understand that "convicted" or "conviction" as defined in Para. 287.133(1)(b), Florida Statutes, means a finding of guilt or a conviction of a public entity crime, with or without an adjudication of guilt, in any federal or state trial court of record relating to charges brought by indictment or information after July 1, 1989, as a result of a jury verdict, non-jury trial, or entry of a plea of guilty or nolo contendere.
4. I understand that an "affiliate" as defined in Para. 287.133(1)(a), Florida Statutes, means:
(i). A predecessor or successor of a person convicted of a public entity crime; or
(ii). Any entity under the control of any natural person who is active in the management of the entity and who has been convicted of a public entity crime. The term "affiliate" includes those officers, directors, executives, partners, shareholders, employees, members, and agents who are active in the management of an affiliate. The ownership by one person of shares constituting a controlling interest in another person, or a pooling of equipment or income among persons when not for fair market value under an arm's length agreement, shall be a prime facie case that one person controls another person. A person who knowingly enters into a joint venture with person who has been convicted of a public entity crime in Florida during the preceding thirty six (36) months shall be considered an affiliate.
5. I understand that a "person" as defined in Para. 287.133(1)(e), Florida Statutes, means any natural person or entity organized under the laws of any state or of the United States with the legal power to enter into a binding contract and which Proposals or applies to Proposal on contracts for the provision of goods or services let by a public entity, or which otherwise transacts or applies to transact business with a public entity. The term "persons" includes those officers, directors, executives, partners, shareholders, employees, members, and agents who are active in management of any entity.

TOWN OF SOUTHWEST RANCHES, FLORIDA
TOWN-WIDE IRRIGATION MAINTENANCE SERVICES

PUBLIC ENTITY CRIMES

Pursuant to the provisions of paragraph (2) (a) of Section 287.133, Florida State Statutes - "A person or affiliate who has been placed on the convicted vendor list following a conviction for a public entity crime may not submit a Proposal on a contract to provide any goods or services to a public entity, may not submit a Proposal on a contract with a public entity for the construction or repair of a public building or public work, may not submit Proposals on leases of real property to a public entity, may not be awarded to perform work as a contractor, supplier, subcontractor, or consultant under a contract with any public entity, and may not transact business with any public entity in excess of the threshold amount Category Two of Sec. 287.017, F.S. for thirty six (36) months from the date of being placed on the convicted vendor list".

[INTENTIONALLY LEFT BLANK]

TOWN OF SOUTHWEST RANCHES, FLORIDA
TOWN-WIDE IRRIGATION MAINTENANCE SERVICES

6. Based on information and belief, the statement which I have marked below is true in relation to the entity submitting this sworn statement. (Indicate which statement applies.)

Neither the entity submitting this sworn statement, nor any of its officers, directors, executives, partners, shareholders, employees, members, or agents who are active in the management of the entity, nor any affiliate of the entity has been charged with and convicted of a public entity crime subsequent to July 1, 1989.

The entity submitting this sworn statement, or one or more of its officers, directors, executives, partners, shareholders, employees, members, or agents who are active in the management of the entity or an affiliate of the entity has been charged with and convicted of a public entity crime subsequent to July 1, 1989.

The entity submitting this sworn statement, or one or more of its officers, directors, executives, partners, shareholders, employees, members, or agents who are active in the management of the entity or an affiliate of the entity has been charged with and convicted of a public entity crime subsequent to July 1, 1989.

However, there has been a subsequent proceeding before a Hearing Officer of the State of Florida, Division of Administrative Hearings and the Final Order entered by the Hearing Officer of the State of Florida, Division of Administrative Hearings and the Final Order entered by the Hearing Officer determined that it was not in the public interest to place the entity submitting this sworn statement on the convicted vendor list. (Attach a copy of the final order.)

I UNDERSTAND THAT THE SUBMISSION OF THIS FORM TO THE CONTRACTING OFFICER FOR THE PUBLIC ENTITY IDENTIFIED IN PARAGRAPH 1 (ONE) ABOVE IS FOR THAT PUBLIC ENTITY ONLY AND, THAT THIS FORM IS VALID THROUGH DECEMBER 31 OF THE CALENDAR YEAR IN WHICH IT IS FILED. I ALSO UNDERSTAND THAT I AM REQUIRED TO INFORM THE PUBLIC ENTITY PRIOR TO ENTERING INTO A CONTRACT IN EXCESS OF THE THRESHOLD AMOUNT PROVIDED IN SECTION 287.017, FLORIDA STATUTES, FOR CATEGORY TWO OF ANY, CHANGE IN THE INFORMATION CONTAINED IN THIS FORM.

By: _____

Craig Luca
(Printed Name)

Controller
(Title)

Sworn to and subscribed before me this 19 day of November, 2014

Personally known Or Produced Identification _____

(Type of Identification)

Notary Public - State of Florida

My Commission Expires 10/31/2015

(Printed, typed, or stamped commissioned name of notary public)

Lisa Binkley

PROPOSER'S SIGNATURE: _____

COMPANY NAME: Prestige Property Maintenance Inc.

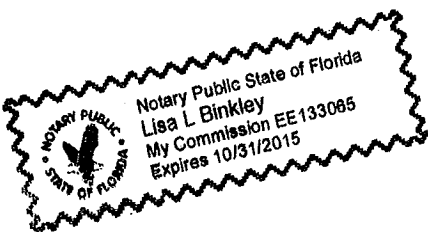

TOWN OF SOUTHWEST RANCHES, FLORIDA
TOWN-WIDE IRRIGATION MAINTENANCE SERVICES

NON-COLLUSIVE AFFIDAVIT

State of FL)

County of BROWARD) ss.

CORRE LICA being first duly sworn deposes and says that:

- 1 He/She is the officer Pres
(Owner, Partner, Officer, Representative or Agent) of
Prestige Property Maint. Inc. the Proposer that has submitted the attached Proposal;
- 2 He/She is fully informed respecting the preparation and contents of the attached Proposal and of all pertinent circumstances respecting such Proposal;
- 3 Such Proposal is genuine and is not a collusive or sham Proposal;
- 4 Neither the said Proposer nor any of its officers, partners, owners, agents, representatives, employees or parties in interest, including this affiant, have in any way colluded, conspired, connived or agreed, directly or indirectly, with any other Proposer, firm, or person to submit a collusive or sham Proposal in connection with the Work for which the attached Proposal has been submitted; or to refrain from proposing in connection with such Work; or have in any manner, directly or indirectly, sought by agreement or collusion, or communication, or conference with any Proposer, firm, or person to fix any overhead, profit, or cost elements of the Proposal or of any other Proposer, or to fix any overhead, profit, or cost elements of the Proposal price or the Proposal price of any other Proposer, or to secure through any collusion, conspiracy, connivance, or unlawful agreement any advantage against (Recipient), or any person interested in the proposed Work;
- 5 The price or prices quoted in the attached Proposal are fair and proper and are not tainted by any collusion, conspiracy, connivance, or unlawful agreement on the part of the Proposer or any other of its agents, representatives, owners, employees or parties in interest, including this affiant.

By: [Signature]
CORRE LICA
 (Printed Name)
Pres
 (Title)

Sworn to and subscribed before me this 19 day of November, 2014
 Personally known
 Or Produced Identification _____

[Signature] (Type of Identification)
 Notary Public - State of _____
 My Commission Expires 10/31/2015
 (Printed, typed, or stamped commissioned name of notary public)

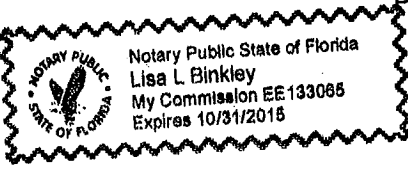

PROPOSER'S SIGNATURE: [Signature]
 COMPANY NAME: Prestige Property Maintenance Inc.

TOWN OF SOUTHWEST RANCHES, FLORIDA
TOWN-WIDE IRRIGATION MAINTENANCE SERVICES



CERTIFICATE OF AUTHORITY (If Corporation or Limited Liability Company)

State of FL)
County of Broward) ss.

I HEREBY CERTIFY that a meeting of the Board of Directors of a corporation or authorized representatives of a Limited Liability Company existing under the laws of the State of FLORIDA, held on 11/18, 20 14, the following resolution was duly passed and adopted:
"RESOLVED, that Corey Lewis, as President of the Corporation or authorized representative of a Limited Liability Company, be and is hereby authorized to execute the Proposal dated, 20 , to the Town of Southwest Ranches and this corporation or Limited Liability Company and his execution thereof, attested by the Secretary of the Corporation or Limited Liability Company, and with the Corporate Seal affixed, shall be the official act and deed of this Corporation or Limited Liability Company."

I further certify that said resolution is now in full force and effect.

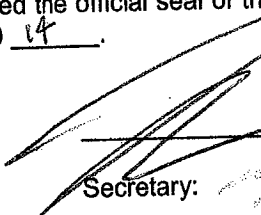
IN WITNESS WHEREOF, I have hereunto set my hand and affixed the official seal of the corporation or Limited Liability Company this 18th day of November, 20 14.

Secretary:
(SEAL)

PROPOSER'S SIGNATURE:

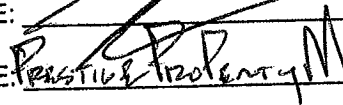
COMPANY NAME: Positive Property Maintenance Inc.

TOWN OF SOUTHWEST RANCHES, FLORIDA
TOWN-WIDE IRRIGATION MAINTENANCE SERVICES

PROPOSER QUALIFICATION

List Number of Irrigation Maintenance Contracts in excess of Fifty Thousand Dollars (\$50,000) per year in the past five (5) years.

Project Name: City of Coral Springs
Client Name: _____
Address: 9551 W Sample Rd, Coral Springs, FL
Contact Person: Louis Goldstein
Contact Person Tel. No.: 954/345-2112

Project Name: City of Tamarac
Client Name: _____
Address: 36011 Nob Hill Road, Tamarac, FL
Contact Person: John Engwiller
Contact Person Tel. No.: 954/597-3727

Project Name: US 1 / Fort Lauderdale - Hollywood Airport
Client Name: Broward County Aviation
Address: 1501 SW 43 St, Ft Lauderdale, FL
Contact Person: Curtis Johnson
Contact Person Tel. No.: 954/359-1250

Project Name: City of Miramar
Client Name: _____
Address: 2300 Civic Center Place, Miramar, FL
Contact Person: Fawazz Massoom
Contact Person Tel. No.: 954/883-5126

Project Name: _____
Client Name: _____
Address: _____
Contact Person: _____
Contact Person Tel. No.: _____

PROPOSER'S SIGNATURE:

COMPANY NAME:

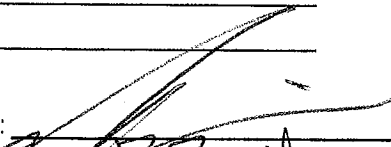
Residential Irrigation Maintenance Inc.

TOWN OF SOUTHWEST RANCHES, FLORIDA
TOWN-WIDE IRRIGATION MAINTENANCE SERVICES

GOVERNMENTAL CONTACT INFORMATION

List any Governmental or Quasi-governmental Agencies for which the Proposer has done business within the past five (5) years.

Name of Agency: SEE ATTACHED

Address: _____

Phone No.: _____ Contact Person: _____

Name of Agency: _____

Address: _____

Phone No.: _____ Contact Person: _____

Name of Agency: _____

Address: _____

Phone No.: _____ Contact Person: _____

Name of Agency: _____

Address: _____

Phone No.: _____ Contact Person: _____

Name of Agency: _____

Address: _____

Phone No.: _____ Contact Person: _____

Name of Agency: _____

Address: _____

Phone No.: _____ Contact Person: _____

Name of Agency: _____

Address: _____

Phone No.: _____ Contact Person: _____

Name of Agency: _____

Address: _____

Phone No.: _____ Contact Person: _____

PROPOSER'S SIGNATURE: _____

COMPANY NAME: PROSWEST IRRIGATION MAINTENANCE INC.

REFERENCES & CONTRACT EXPERIENCE

CITY OF CORAL SPRINGS

9551 West Sample Road
Coral Springs, Florida 33075-4501

Contact: Louis Goldstein
Parks Superintendent
(954) 345-2112 Fax (954) 345-2111
Email: lg@coralsprings.org

Scope: City wide maintenance of right of ways, lift stations, canal headers, cul-de-sacs, right of ways, neighborhood parks, and linear parks including: lawn mowing, hedge & shrub trimming, chemical control, and fertilization.

(Primary contractor - \$516,000 annually)

Date of Contract: October 1993 - present

BROWARD COUNTY

AVIATION DEPARTMENT

1501 Southwest 43rd Street
Fort Lauderdale, Florida 33315

Contact: Curtis Johnson
Contract Supervisor
(954) 359-1250 Fax (954) 252-2297
Email: curjohnson@broward.org

US 1 Corridor

Scope: US 1 at Fort Lauderdale / Hollywood International Airport grounds maintenance including: lawn mowing, hedge & shrub trimming, chemical control, irrigation maintenance, tree trimming, fertilization, sod and mulch installation, landscaping, and tree trimming.

(Primary contractor - \$323,000 annually)

Date of Contract: November 2000 - May 2006
January 2011 - present

Fort Lauderdale / Hollywood Int'l Airport

Scope: Fort Lauderdale / Hollywood International Airport grounds maintenance including: lawn mowing, hedge & shrub trimming, chemical control, irrigation maintenance, tree trimming, fertilization, sod and mulch installation, landscaping, tree trimming and hurricane clean up and remediation.

(Primary contractor - \$324,000 annually)

Date of Contract: May 2004 - September 2009
February 2012 - present

CITY OF TAMARAC

Public Works
6011 Nob Hill Road
Tamarac, Florida 33321-2401

Contact: John Engwiller
Operations Manager - Public Works
(954) 597-3727 Fax (954) 597-3720
Email: John.Engwiller@tamarac.org

Scope: City wide maintenance of right of ways, medians, roadways and select facilities including: lawn mowing, hedge & shrub trimming, chemical control, irrigation maintenance, mulch installation, tree trimming and fertilization.

(Primary contractor - \$949,000 annually)

Date of Contract: January 2000 - present

**BOCA WEST - VILLAGE OF
BRIDGEWOOD MASTER ASSOCIATION**

2400 Bridgewood Drive
Boca Raton, Florida 33434

Contact: Carol Meyer
Property Manager
(561) 483-7133 Fax (561) 483-7134
Email: office@villageofbridgewood.com

Scope: Grounds maintenance of Master Association and six Associations including: lawn mowing, hedge & shrub trimming, chemical control, irrigation maintenance, mulch installation, landscape installations and fertilization.
(Primary contractor -)

Date of Contract: February 2002 - present

**BROWARD COUNTY
WATER & WASTEWATER SERVICES**

2555 West Copans Road
Pompano Beach, Florida 33069

Contact: Glen Spencer
Water Management Division
(954) 831-0753 Fax (954) 831-3285
E-mail: gspencer@broward.org

Scope: General maintenance and mowing of countywide canal right of way easements including: trash removal, removal of debris, trees, aquatic and exotic vegetation.
(Primary contractor)

Date of Contract: August 2011 - present

CITY OF MIRAMAR

2300 Civic Center Place
Miramar, Florida 33025

Contact : Fawwaz Massoom
Landscape Inspector
(954) 883-5126
E-mail: ffmassoom@cimiramar.fl.us

Scope: General maintenance and mowing of citywide right of way easements, medians, water treatment facilities including lawn mowing, hedge & shrub trimming, chemical control, fertilization, irrigation maintenance, mulch installation, and landscape installation. (Primary contractor)

Date of Contract: December 2011 - present

CITY OF SUNRISE

6466 Northwest 20th Street
Sunrise, Florida 33313

Contact: Bill Ginter
Division Director of Grounds Maintenance
(954) 572-2385 Fax (954) 572-2409
Email: WGinter@cityofsunrise.org

Scope: City wide grounds maintenance of medians, swales, and intersections including: lawn mowing, chemical control, mulch installation, and fertilization.
(Primary contractor)

Date of Contract: October 2008 - September 2012

TOWN OF SOUTHWEST RANCHES, FLORIDA
TOWN-WIDE IRRIGATION MAINTENANCE SERVICES

SUBCONTRACTORS

List all Subcontractors to be used on this project if the Proposer is awarded a contract.

**CLASSIFICATION
OF WORK**

**NAME, ADDRESS, PHONE
OF SUBCONTRACTORS**

None

PROPOSER'S SIGNATURE: _____

COMPANY NAME: _____

[Handwritten Signature]
Reserve Irrigation Maintenance Inc

TOWN OF SOUTHWEST RANCHES, FLORIDA
TOWN-WIDE IRRIGATION MAINTENANCE SERVICES

PROPOSED MANAGEMENT PLAN

Provide a written description of proposed plan to accomplish work, including structure of provider, organizational chart and auxiliary services offered, crews, personnel and equipment to be dedicated to this project, if the Proposer is awarded a Contract. (Use additional sheets if necessary.)

see attached

PROPOSER'S SIGNATURE:

COMPANY NAME:

[Handwritten Signature]
Prestige Property Maintenance Inc.

Management

For services provided for the Town of Southwest Ranches – IRRIGATION MAINTENANCE, our team of professionals will be involved in all aspects of the project. Fred Lica will be the assigned Project Manager. Mr. Lica has held a Broward County Spec Plumber – Lawn Sprinkler Certificate of Competency since 1994 and is the company qualifying agent. Mr. Lica has 30 years of irrigation experience and currently holds certification for “Know the Flow”, Florida Best Management Practices, Rainbird Maxicon Level 1 Software and Hardware and Basic Tree Pruning. Our project team consists of Mike Digirolamo, irrigation manager, who has 22 years of experience in the irrigation industry and is qualified to install and design irrigation systems and pump stations; Darryl Marshall, chief technician, who has 19 years of experience in the irrigation industry and is an expert in troubleshooting, solving pump problems, wiring and electrical and holds several certificates of completion from the Rainbird Academy.

Dedicated Personnel and Equipment

Prestige Property Maintenance proposes the following equipment and personnel structure for the Town of Southwest Ranches for listed locations:

- (A) 1 (two man) irrigation crew to fully operate all irrigation zones; replace, repair or clean all heads, lines, valves, valve boxes and controllers, as needed during the monthly inspections. They will report to the Town Designee any sprinkler system malfunctions or damage immediately by phone. A formal written report will be sent within 24 hours.
- (B) 1 (one man) crew will visit sites once a week, or as may otherwise be required to check for correct time clock operation.
- (C) All irrigation crews will have an irrigation truck stocked with parts and tools to complete the task at hand.
- (D) Walk behind Ditch Witch trencher and skid loader equipment are available for installations and repairs.

Auxiliary Services Offered

The following are the auxiliary services provided by Prestige Property Maintenance:

- Commercial and Multi Family Lawn Maintenance
- Landscaping- Installation, Design, and Maintenance
- Tree Trimming and Removal
- Pest Control (Turf and Plant)
- Wholesale Plant and Tree Nursery
- Backhoe, Skid Loader, and Heavy Equipment Rentals
- Irrigation Repair and Installation
- Fertilization
- Mulch Installation
- Tractor Mowing

Prestige Property Management and Maintenance, Inc.

Organizational Chart

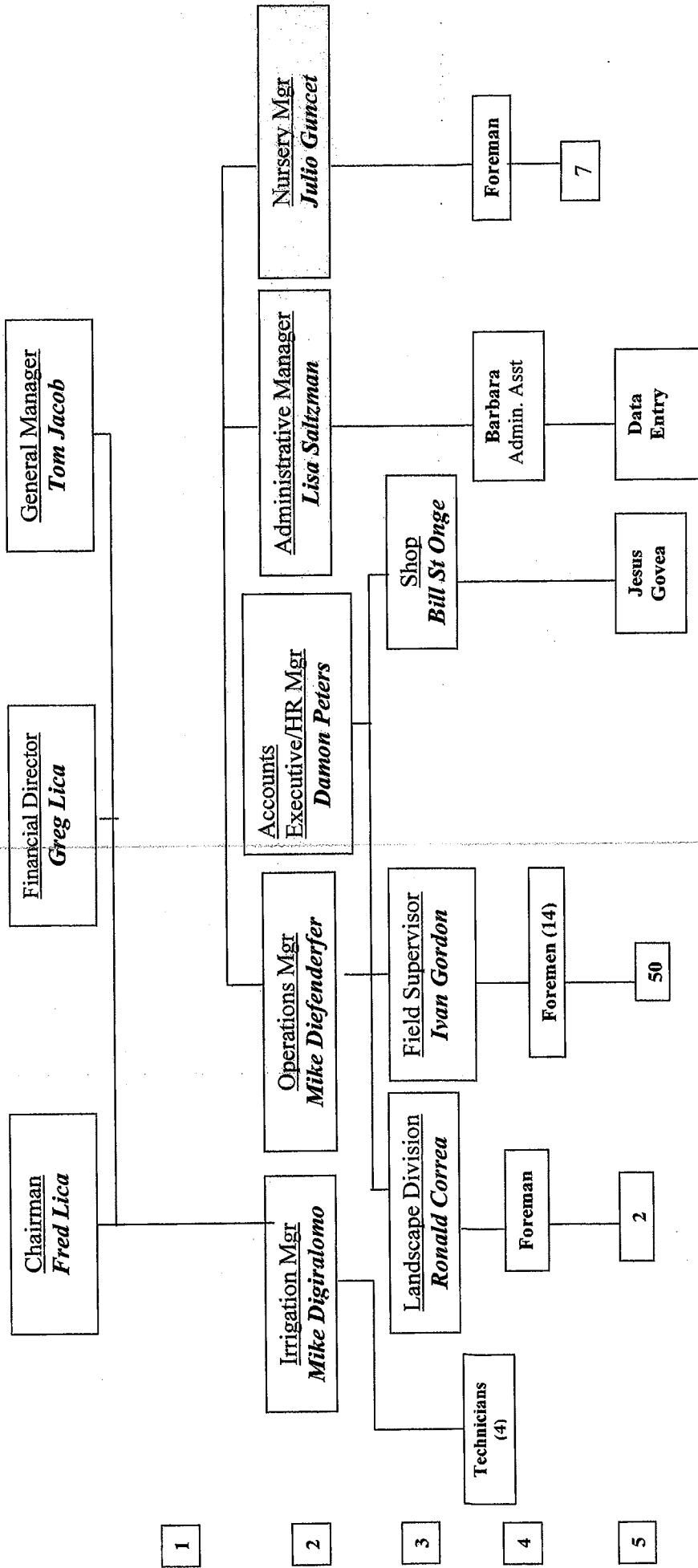

COMPANY PROFILE

PRESTIGE PROPERTY MAINTENANCE is a full service commercial grounds maintenance company which has served South Florida since 1986. PRESTIGE can handle all of your grounds maintenance needs; including lawn maintenance, irrigation installation, maintenance & repairs, tree trimming & removal, fertilization, weed & pest control, mulch blowing services and landscape design & installation services, including seasonal color, all with plants from our own 25 acre plant & tree farm.

As a mid-sized, family owned and operated company, PRESTIGE, over its twenty five plus years in the grounds maintenance industry, has earned itself a reputation of being able to provide both personalized and professional quality service to its customers. As evidenced by its' broad customer base from condos & homeowners' associations, apartment, office, & industrial complexes, office buildings & shopping centers and municipalities to high profile jobs like the Ft Lauderdale/Hollywood International Airport and secure facilities like the Florida Power & Light's Port Everglades plant and sub - stations, PRESTIGE gets the results you're looking for. PRESTIGE has been able to maintain and increase its revenues over the years by providing quality service that, in turn, promotes customer loyalty and retention, renewed service contracts and referrals. PRESTIGE's focus on customer satisfaction is the primary component of its long term success in an industry that is often plagued with fly-by-night companies.

Key personnel at PRESTIGE include GREG LICA, Controller; FRED LICA, General Manager; TOM JACOB, Accounts Manager; and MIKE DIEFENDERFER, Operations Manager. All of these individuals have been with PRESTIGE since its inception. A brief description of the key personnel's background and experience is set forth below.

GREG LICA holds a bachelor's degree in Accounting and brings to PRESTIGE more than twenty-five years in Accounting and Marketing, in addition to Small Business Management. Greg is also a State licensed Property Manager and Real Estate Broker, so he knows the importance of maintaining your property's curb appeal to maximize its value. At PRESTIGE, Greg's responsibilities include all accounting and marketing functions. His knowledge in the financial and insurance arena has allowed PRESTIGE to remain a viable business in times where other similar businesses have suffered or even failed.

FRED LICA holds a bachelor's degree in Small Business Management and is also a State licensed Irrigation Contractor. Fred is deemed an irrigation expert in South Florida and is known for his trouble shooting skills. Fred is also a certified member of the Florida Nurserymen and Growers Association. At PRESTIGE, Fred is an integral part of our estimating and inspection team, as well as overseeing the Irrigation and Landscaping Divisions.

TOM JACOB is recognized in South Florida as an expert in arboriculture and turf & ornamental pest control and offers customers his expertise in all aspects of the horticulture industry. He is an International Society of Arboriculture - Certified Arborist and licensed as a "Class A" tree trimmer, as well as a certified and licensed Pest Control Operator. At PRESTIGE, Tom is an integral part of our estimating and inspection team. In addition to being responsible for the Lawn Maintenance and Tree Divisions, Tom heads the Employee Job Safety Team. As Accounts Manager, Tom lends to PRESTIGE his ability to effectively and positively communicate with PRESTIGE's customers.

MIKE DIEFENDERFER is a certified member of the Landscape Managers Association. In addition, Mike studies at Broward Community College to enhance his horticultural knowledge and skills. As yet another integral part of our estimating and inspection team, Mike, as Operations Manager, is responsible for personnel scheduling and job supervision. Mike also has a passion for Landscaping, making him an important part of our landscaping design team and making him a valuable consultant to customers.

TOWN OF SOUTHWEST RANCHES, FLORIDA
TOWN-WIDE IRRIGATION MAINTENANCE SERVICES

PROPOSER DISCLOSURE OF LITIGATION HISTORY

The Proposer's response to this questionnaire will be utilized as part of the Town's overall Proposal Evaluation and Contractor selection.

List all cases where Proposer has been a party to litigation or arbitration (or other binding dispute resolution procedure), whether plaintiff or defendant (petitioner or respondent), within the past five (5) years including case name, case number, jurisdiction, whether case has been resolved or is still pending, and a brief description of the nature of the case.

Case Name: _____
Case Number: _____
Jurisdiction: _____
Plaintiff: _____
Defendant: _____
Case Status: Resolved _____ Pending _____
Brief description of nature of case: _____

No Material Litigation Brought
Against or By Proposer

Case Name: _____
Case Number: _____
Jurisdiction: _____
Plaintiff: _____
Defendant: _____
Case Status: Resolved _____ Pending _____
Brief description of nature of case: _____

Case Name: _____
Case Number: _____
Jurisdiction: _____
Plaintiff: _____
Defendant: _____
Case Status: Resolved _____ Pending _____
Brief description of nature of case: _____

PROPOSER'S SIGNATURE: _____

COMPANY NAME: _____

[Handwritten Signature]
RESTITE PROPERTY MAINTENANCE INC.

TOWN OF SOUTHWEST RANCHES, FLORIDA
TOWN-WIDE IRRIGATION MAINTENANCE SERVICES

STATEMENT OF NO RESPONSE

Recipients of this solicitation may elect not to respond. The Town is interested in learning the reason(s) for non-response. If you elect not to respond with an offer to this solicitation, the Town requests that the reason(s) be indicated below and this form returned to:

Juanita Romance, Procurements and Special Projects
Town of Southwest Ranches
13400 Griffin Road
Southwest Ranches, FL 33330
or
Email: jromance@southwestranches.org

REASONS

1. _____ Do not Offer this product/service or equivalent.
2. _____ Schedule would not permit.
3. _____ Insufficient time to respond to solicitation.
4. _____ Unable to meet specifications / scope of work.
5. _____ Specifications "too tight" (i.e. geared to specific brand or manufacturer).
6. _____ Specifications not clear.
7. _____ Unable to meet bond and / or insurance requirements.
8. _____ Solicitation addressed incorrectly, delayed in forwarding of mail.
9. _____ Other (Explanation provided below or by separate attachment).

Explanation: _____

The Town may delete the names of those persons or businesses who fail to respond to three (3) solicitations, who fail to return this Statement, or as requested.

Desire to receive future Town solicitations? Yes No

COMPANY: _____

NAME: _____ TITLE: _____

ADDRESS: _____

TELEPHONE: (_____) _____ DATE: _____

ACKNOWLEDGEMENT of ADDENDA

Proposer shall indicate receipt of addendum by initialing below for each addenda received.

Addenda No.1 FL

Addenda No.2 FL

Addenda No.3 FL

Addenda No.4 _____

ADDENDUM #1
Town-Wide Irrigation Maintenance Services
RFP No. 14-012

This Addenda reflects changes to Town Zones. Attached are pages 15, 18 and 19 with the changes and should be replaced in your Proposal Document. All changes are highlighted for easy reference.

Juanita Romance
Procurement and Special Projects Coordinator
10/22/2014

ADDENDUM #2
Town-Wide Irrigation Maintenance Services
RFP No. 14-012

October 23, 2104 Mandatory Pre-Proposal Conference Questions and Answers.

Note: The following questions were asked and answered during the mandatory pre-proposal conference. These notes are provided as a courtesy to potential proposers.

1. Q: How will proposal security be returned if the proposal is not awarded? How will proposal security be returned if a Contract is awarded?

A: **CLARIFICATION:** Proposal security submitted will be held by the Town until the beginning of the Contract associated with this RFP. Subsequent to Contract Commencement, it shall be the responsibility of each proposer to submit a written request for return of their proposal security from the office of the Town Procurement and Special Projects Coordinator, whose email address is: jromance@southwestranches.org.

2. Q: Do the prices submitted with the proposal apply to the initial 30-day inspection and report?

A: **CLARIFICATION:** Yes. The Town will rely on the Contractor's submitted unit prices in the proposal for items discovered to require repair within the initial 30-day inspection and reporting period prior to the commencement of the contract.

3. Q: Is the price for weekly checking of time clocks to be included in the proposal?

A: **CLARIFICATION:** Yes, time clocks are to be checked for proper operation and adjustment once per week and this item shall be included within the Base Proposal.

4. Q: Are there any other Associations for which membership may be evaluated for additional points?

A: **CLARIFICATION:** The Selection Committee will evaluate the proposers' professional certifications and memberships as listed in table in section 10.3 of the RFP. Proposers should include with their proposals evidence of any certifications and/or memberships in professional associations that may assist the Selection Committee to evaluate the proposer's qualifications.

5. Q: How many points are available for Professional Certifications and Memberships? Is the total available 5 points or 5 points per certification/association?

A: **CLARIFICATION:** The total available evaluation points for Professional Certifications and Memberships is 5.

6. Q: Regarding damage to irrigation systems. Is time included or billable?

A: **CLARIFICATION:** In accordance with section P/3., the Contractor shall be responsible for the labor and supervision to make minor irrigation repairs to the risers, sprinkler heads and any lines up to and including two (2) inches in diameter as required to keep the systems operating. The time for this service is considered to be included in the base proposal.

ADDENDUM #2
Town-Wide Irrigation Maintenance Services
RFP No. 14-012

For reimbursable repair work including time and materials, (major repairs referenced in section P/3.), the contractor shall provide its proposal in accordance with unit prices submitted in the **MAINTENANCE PROPOSAL: PRICE LIST BY SERVICE (AUXILIARY SERVICES)** and this work shall require authorization by the Town's Designee prior to commencement.

7. Q: Will there be any other company maintaining or are the unit prices requested in the event of breach?

A: **CLARIFICATION:** This procurement anticipates an award of Contract to a single proposer. The unit prices listed and requested within this RFP are as comprehensive a list as possible of what parts were originally installed and that currently are in use in the irrigation systems. The proposer should be prepared to provide unit prices for all replacement parts (or approved equal) and labor at the unit price rates submitted in his proposal for the duration of the contract.

Juanita Romance
Procurement and Special Projects Coordinator
11/06/2014

ADDENDUM #3
Town-Wide Irrigation Maintenance Services
RFP No. 14-012

Question: What is the current monthly billing of your current vendor?

Answer: The current billing varies depending on season for the type of maintenance and service provided.

The Town currently does not have a facilities maintenance contract. Irrigation is billed either monthly or quarterly, depending on location, and the current annual total base bid for all routine irrigation maintenance is \$9,760.

Question: Is the current scope of work the same as the new RFP?

Answer: Please refer to the frequency schedule for each service category, maintenance zone/location.

Question: Is the Town going to award all RFP's to 1 vendor or more?

Answer: The Town intends to make an award to the responsive and responsible Proposer(s) whose proposal is determined to be the most advantageous to the Town, and in accordance with the evaluation factors set forth in the RFP and the Town's Procurement Code. Each RFP will be treated as its own separate contract.

Question: Does the contractor have to provide a full time onsite project manager for each contract?

Answer: Reference Sections D/ GENERAL REQUIREMENTS and E/SPECIAL REQUIREMENTS for applicable requirements for project manager or site supervisor.
Each RFP stands on its own.

Question: In reference to the price sheets, to avoid confusion, should the price sheet state the frequency of service next to the unit price?

Answer: Please refer to the frequency schedule for each service category, maintenance zone/location.

Juanita Romance
Procurement and Special Projects Coordinator
November 7, 2014

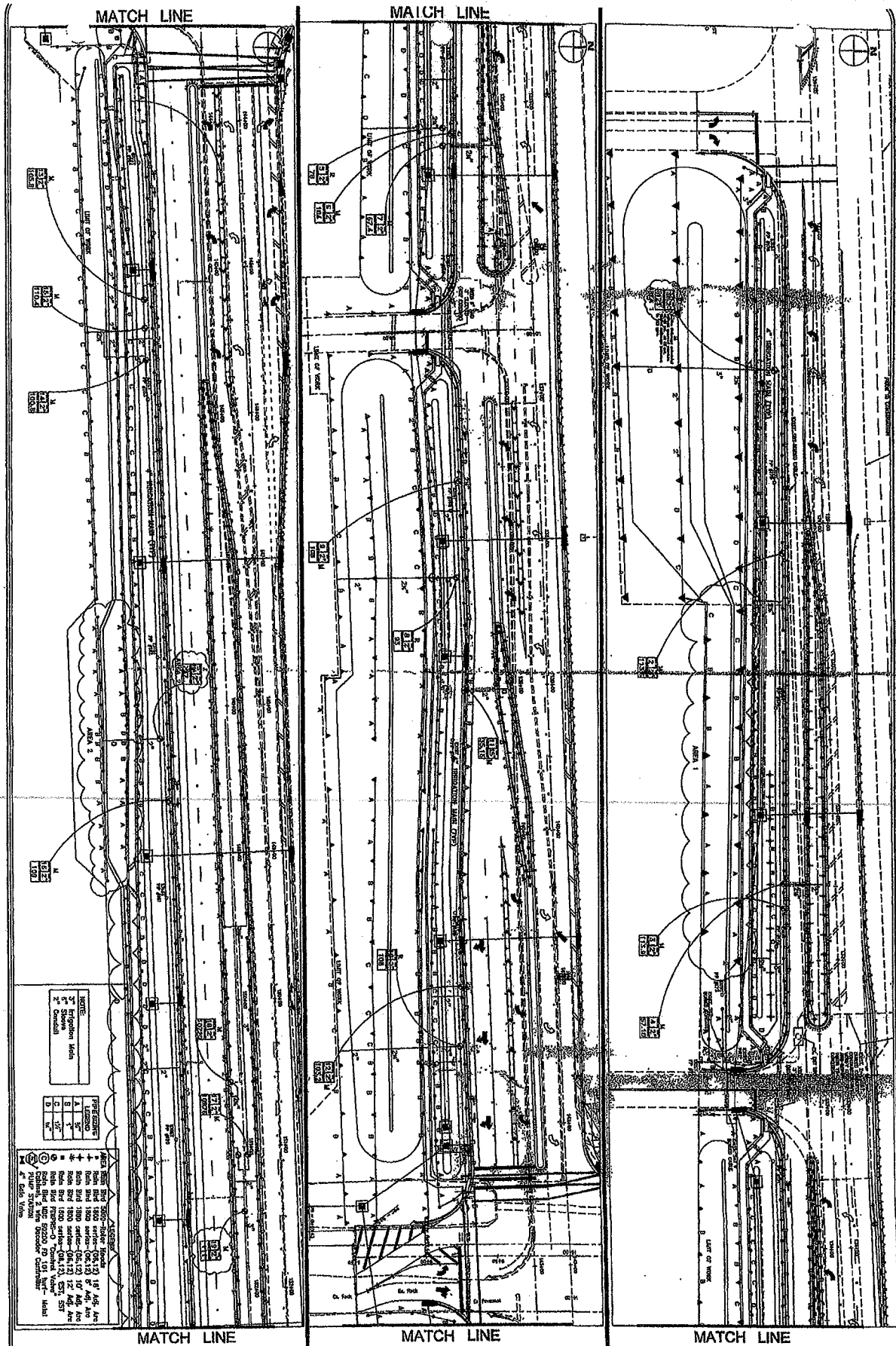

<p>NOTE: 1. All dimensions are in feet unless otherwise noted.</p> <p>2. All structures are to be constructed of concrete unless otherwise noted.</p> <p>3. All structures are to be finished with a smooth surface unless otherwise noted.</p> <p>4. All structures are to be painted with a white enamel paint unless otherwise noted.</p> <p>5. All structures are to be installed in accordance with the manufacturer's instructions.</p> <p>6. All structures are to be installed in accordance with the local building codes.</p> <p>7. All structures are to be installed in accordance with the local health department regulations.</p> <p>8. All structures are to be installed in accordance with the local fire department regulations.</p> <p>9. All structures are to be installed in accordance with the local utility regulations.</p> <p>10. All structures are to be installed in accordance with the local zoning regulations.</p>

11/27/01 2884-10 15 OF 81	PROJECT TITLE GRIFFIN ROAD IRRIGATION PLAN	DESIGNED CHECKED DATE 11/27/01	CCL CONSULTANTS, INC. ENGINEERS • SURVEYORS • PLANNERS LANDSCAPE ARCHITECTS • ENVIRONMENTAL CONSULTANTS 1800 PINE COTTON BLVD. • SUITE 100 • PALM BEACH, FL 33484 • (561) 875-1500 PALM BEACH • ORLANDO	<table border="1"> <tr> <th>REV</th> <th>DATE</th> <th>DESCRIPTION</th> </tr> <tr> <td> </td> <td> </td> <td> </td> </tr> <tr> <td> </td> <td> </td> <td> </td> </tr> </table>	REV	DATE	DESCRIPTION						
	REV	DATE	DESCRIPTION										

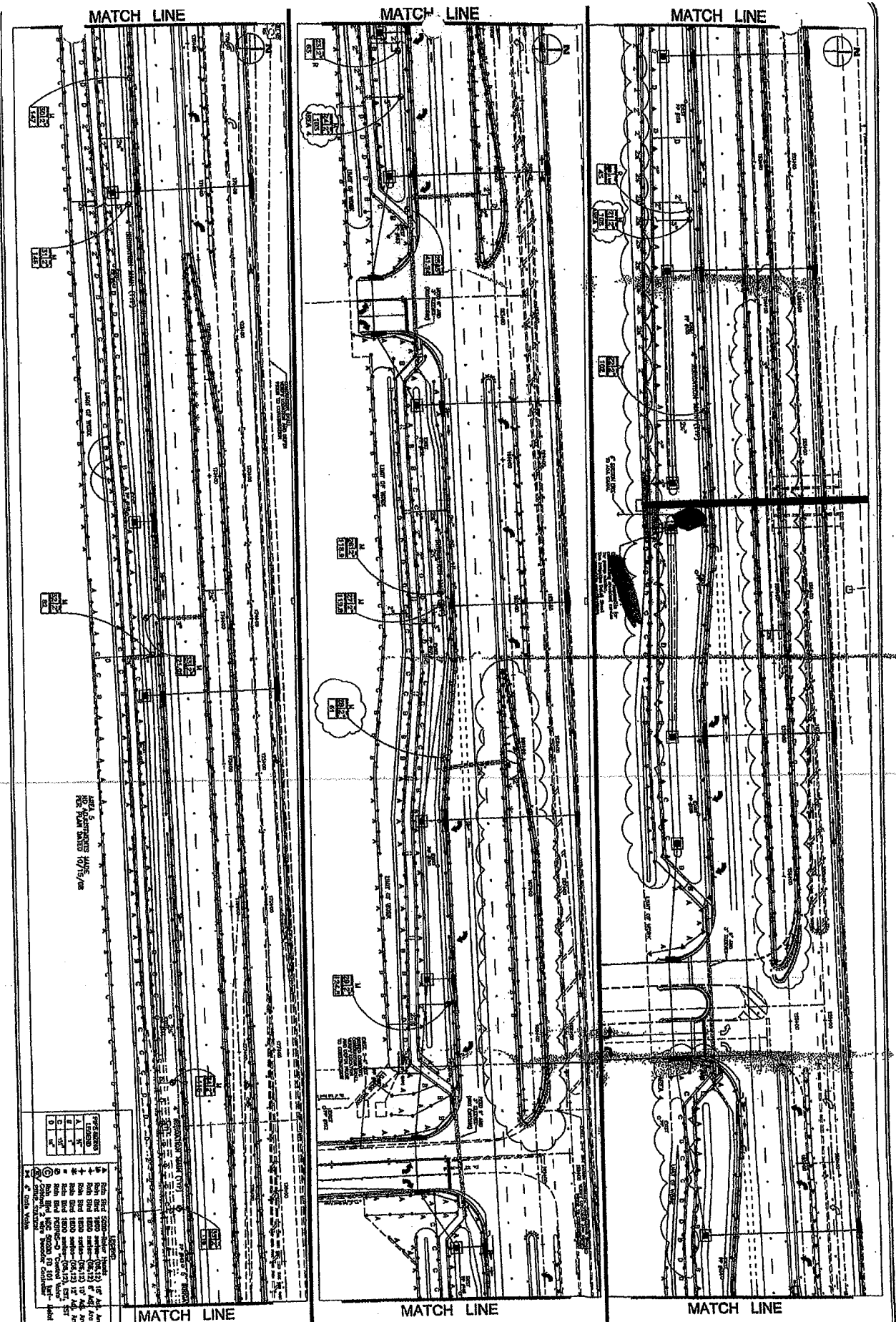

GRIFIN ROAD
IRRIGATION PLAN

DATE: 11/27/08

C.C.I. CONSULTANTS, INC.
 ENGINEERS • SURVEYORS • PLANNERS
 LANDSCAPE ARCHITECTS • ENVIRONMENTAL CONSULTANTS

2205 PINE CROWL BLVD. N. • SUITE 100 • PALM BEACH, FL 33404 • (561) 974-1300
 PALM BEACH • DELAND

NO.	DATE	DESCRIPTION	BY
1			
2			
3			
4			
5			
6			
7			
8			
9			
10			
11			
12			
13			
14			
15			
16			
17			
18			
19			
20			
21			
22			
23			
24			
25			
26			
27			
28			
29			
30			
31			
32			
33			
34			
35			
36			
37			
38			
39			
40			
41			
42			
43			
44			
45			
46			
47			
48			
49			
50			
51			
52			
53			
54			
55			
56			
57			
58			
59			
60			
61			
62			
63			
64			
65			
66			
67			
68			
69			
70			
71			
72			
73			
74			
75			
76			
77			
78			
79			
80			
81			
82			
83			
84			
85			
86			
87			
88			
89			
90			
91			
92			
93			
94			
95			
96			
97			
98			
99			
100			

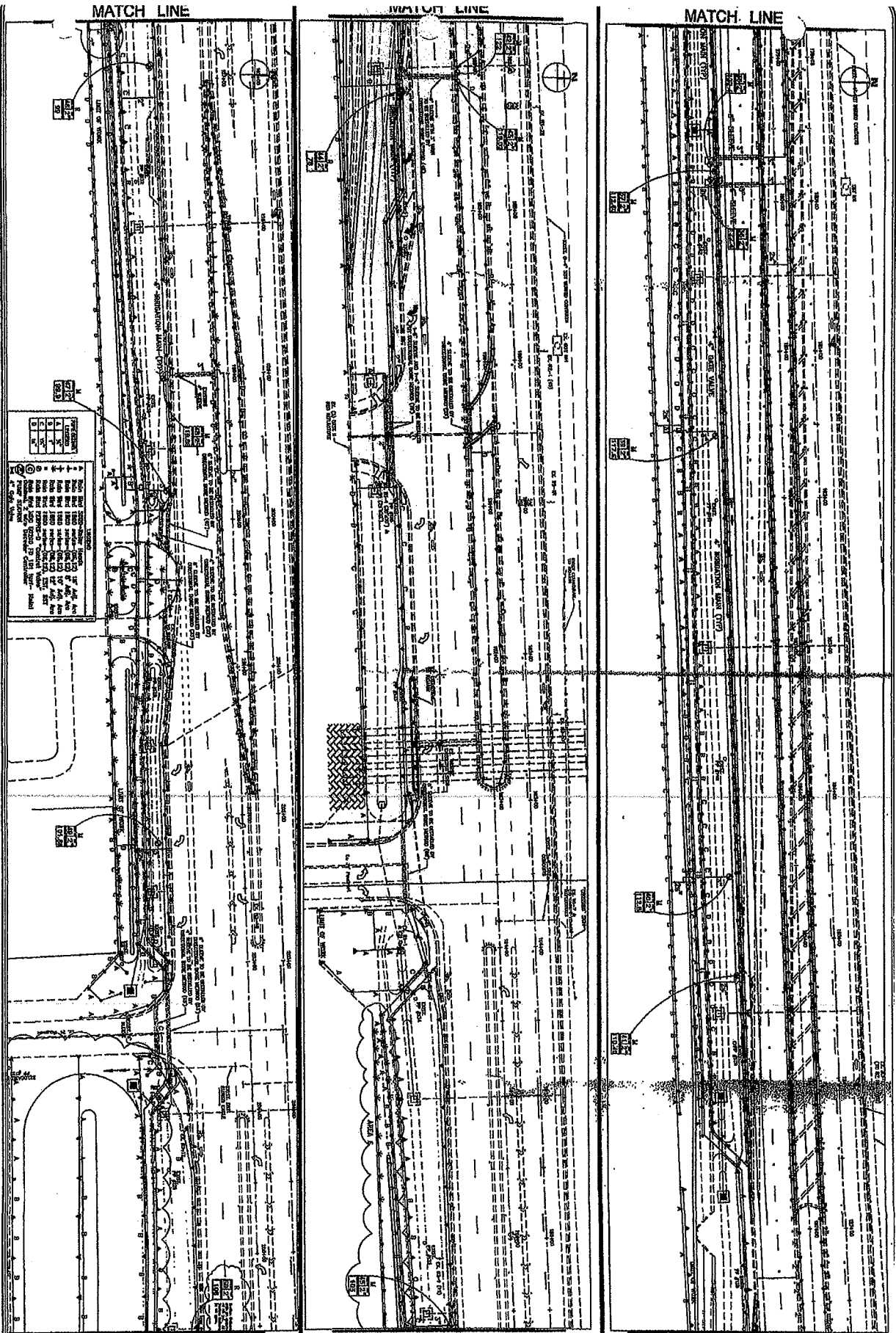

GRIFFIN ROAD	
IRRIGATION PLAN	
DATE: 11/27/05	BY: [Signature]

DESIGNED BY: [Signature]	CHECKED BY: [Signature]
DATE: 11/27/05	

C.C.I. CONSULTANTS, INC.
 ENGINEERS • SURVEYORS • PLANNERS
 ARCHITECTS • ENVIRONMENTAL CONSULTANTS

2310 EAST CENTRAL AVENUE, SUITE 100 • POKOKA HILLS, FL 33614 • (813) 947-1100
 PALM BEACH • ORLANDO

NO.	DATE	DESCRIPTION

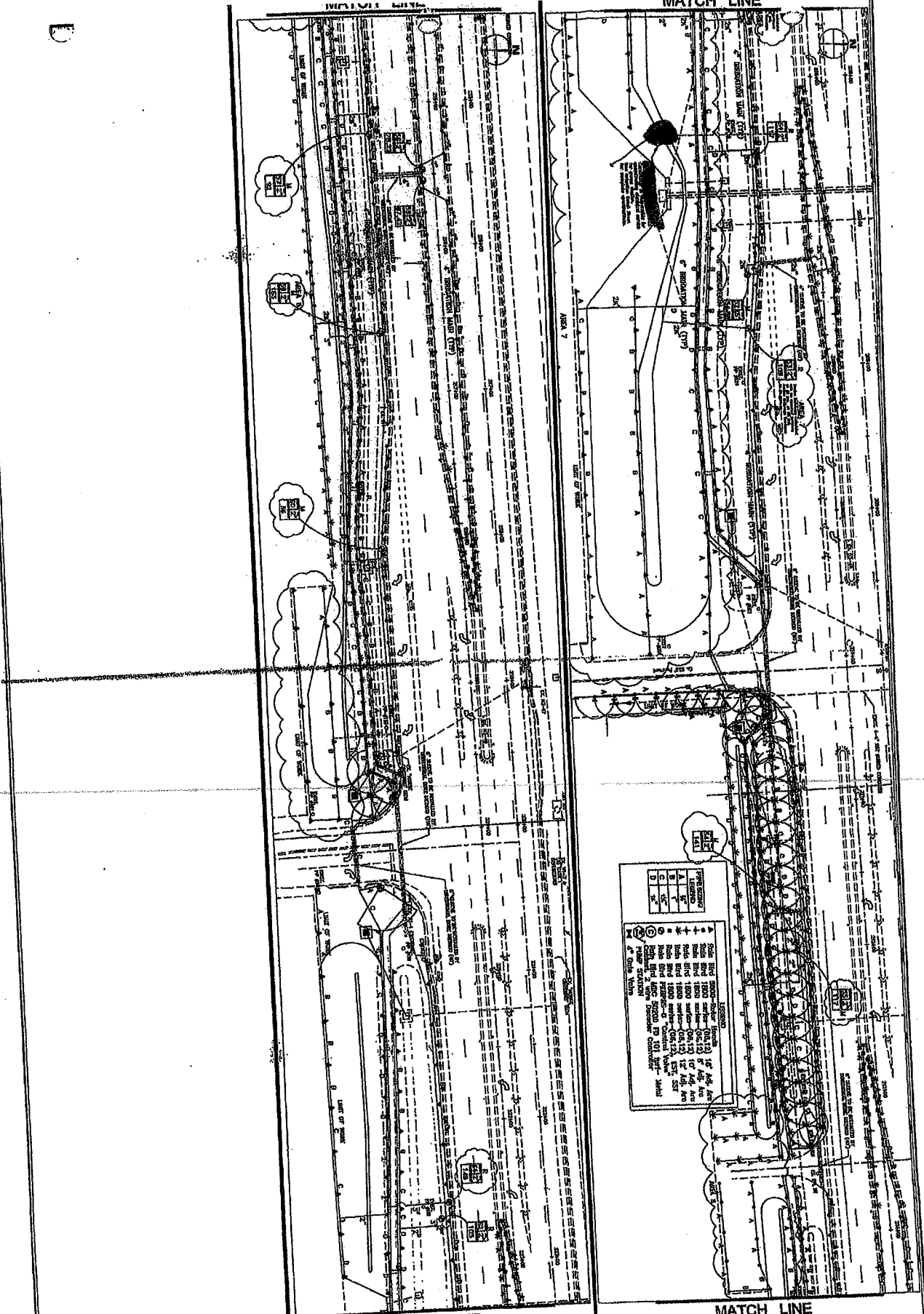

ITEM	DESCRIPTION	QUANTITY	UNIT
1	12" HDPE Pipe	1000	ft
2	8" HDPE Pipe	2000	ft
3	4" HDPE Pipe	4000	ft
4	2" HDPE Pipe	8000	ft
5	1" HDPE Pipe	16000	ft
6	1/2" HDPE Pipe	32000	ft
7	1/4" HDPE Pipe	64000	ft
8	1/2" CPVC Pipe	16000	ft
9	1" CPVC Pipe	8000	ft
10	2" CPVC Pipe	4000	ft
11	4" CPVC Pipe	2000	ft
12	8" CPVC Pipe	1000	ft
13	12" CPVC Pipe	500	ft
14	1/2" CPVC Tee	16000	ft
15	1" CPVC Tee	8000	ft
16	2" CPVC Tee	4000	ft
17	4" CPVC Tee	2000	ft
18	8" CPVC Tee	1000	ft
19	12" CPVC Tee	500	ft
20	1/2" CPVC Elbow	16000	ft
21	1" CPVC Elbow	8000	ft
22	2" CPVC Elbow	4000	ft
23	4" CPVC Elbow	2000	ft
24	8" CPVC Elbow	1000	ft
25	12" CPVC Elbow	500	ft
26	1/2" CPVC Coupling	16000	ft
27	1" CPVC Coupling	8000	ft
28	2" CPVC Coupling	4000	ft
29	4" CPVC Coupling	2000	ft
30	8" CPVC Coupling	1000	ft
31	12" CPVC Coupling	500	ft
32	1/2" CPVC Plug	16000	ft
33	1" CPVC Plug	8000	ft
34	2" CPVC Plug	4000	ft
35	4" CPVC Plug	2000	ft
36	8" CPVC Plug	1000	ft
37	12" CPVC Plug	500	ft
38	1/2" CPVC Cap	16000	ft
39	1" CPVC Cap	8000	ft
40	2" CPVC Cap	4000	ft
41	4" CPVC Cap	2000	ft
42	8" CPVC Cap	1000	ft
43	12" CPVC Cap	500	ft
44	1/2" CPVC Tee	16000	ft
45	1" CPVC Tee	8000	ft
46	2" CPVC Tee	4000	ft
47	4" CPVC Tee	2000	ft
48	8" CPVC Tee	1000	ft
49	12" CPVC Tee	500	ft
50	1/2" CPVC Elbow	16000	ft
51	1" CPVC Elbow	8000	ft
52	2" CPVC Elbow	4000	ft
53	4" CPVC Elbow	2000	ft
54	8" CPVC Elbow	1000	ft
55	12" CPVC Elbow	500	ft
56	1/2" CPVC Coupling	16000	ft
57	1" CPVC Coupling	8000	ft
58	2" CPVC Coupling	4000	ft
59	4" CPVC Coupling	2000	ft
60	8" CPVC Coupling	1000	ft
61	12" CPVC Coupling	500	ft
62	1/2" CPVC Plug	16000	ft
63	1" CPVC Plug	8000	ft
64	2" CPVC Plug	4000	ft
65	4" CPVC Plug	2000	ft
66	8" CPVC Plug	1000	ft
67	12" CPVC Plug	500	ft
68	1/2" CPVC Cap	16000	ft
69	1" CPVC Cap	8000	ft
70	2" CPVC Cap	4000	ft
71	4" CPVC Cap	2000	ft
72	8" CPVC Cap	1000	ft
73	12" CPVC Cap	500	ft

GRIFFIN ROAD IRRIGATION PLAN

DATE: 11/27/06

CCL CONSULTANTS, INC.
 ENGINEERS • SURVEYORS • PLANNERS
 LANDSCAPE ARCHITECTS • ENVIRONMENTAL CONSULTANTS

2500 PARK CENTRAL BLVD. • SUITE 100 • DALLAS, TEXAS 75244 • (972) 442-2800
 5000 W. WILSON BLVD. • SUITE 100 • DALLAS, TEXAS 75244 • (972) 442-2800

NO.	DATE	DESCRIPTION	BY
1			
2			
3			
4			
5			
6			
7			
8			
9			
10			
11			
12			
13			
14			
15			
16			
17			
18			
19			
20			
21			
22			
23			
24			
25			
26			
27			
28			
29			
30			
31			
32			
33			
34			
35			
36			
37			
38			
39			
40			
41			
42			
43			
44			
45			
46			
47			
48			
49			
50			
51			
52			
53			
54			
55			
56			
57			
58			
59			
60			
61			
62			
63			
64			
65			
66			
67			
68			
69			
70			
71			
72			
73			
74			
75			
76			
77			
78			
79			
80			
81			
82			
83			
84			
85			
86			
87			
88			
89			
90			
91			
92			
93			
94			
95			
96			
97			
98			
99			
100			

EAST PUMP STATION @ STA. 207+25		EAST PUMP STATION @ STA. 207+25		EAST PUMP STATION @ STA. 207+25	
LINE NO.	PIPE DIA.	PIPE LENGTH	START STA.	END STA.	PIPE DIA.
1	12"	240	145+00	145+24	12"
2	12"	120	145+24	145+48	12"
3	12"	120	145+48	145+72	12"
4	12"	120	145+72	145+96	12"
5	12"	120	145+96	146+20	12"
6	12"	120	146+20	146+44	12"
7	12"	120	146+44	146+68	12"
8	12"	120	146+68	146+92	12"
9	12"	120	146+92	147+16	12"
10	12"	120	147+16	147+40	12"
11	12"	120	147+40	147+64	12"
12	12"	120	147+64	147+88	12"
13	12"	120	147+88	148+12	12"
14	12"	120	148+12	148+36	12"
15	12"	120	148+36	148+60	12"
16	12"	120	148+60	148+84	12"
17	12"	120	148+84	149+08	12"
18	12"	120	149+08	149+32	12"
19	12"	120	149+32	149+56	12"
20	12"	120	149+56	150+00	12"

WEST PUMP STATION @ STA. 155+00		WEST PUMP STATION @ STA. 155+00		WEST PUMP STATION @ STA. 155+00	
LINE NO.	PIPE DIA.	PIPE LENGTH	START STA.	END STA.	PIPE DIA.
1	12"	240	155+00	155+24	12"
2	12"	120	155+24	155+48	12"
3	12"	120	155+48	155+72	12"
4	12"	120	155+72	155+96	12"
5	12"	120	155+96	156+20	12"
6	12"	120	156+20	156+44	12"
7	12"	120	156+44	156+68	12"
8	12"	120	156+68	156+92	12"
9	12"	120	156+92	157+16	12"
10	12"	120	157+16	157+40	12"
11	12"	120	157+40	157+64	12"
12	12"	120	157+64	157+88	12"
13	12"	120	157+88	158+12	12"
14	12"	120	158+12	158+36	12"
15	12"	120	158+36	158+60	12"
16	12"	120	158+60	158+84	12"
17	12"	120	158+84	159+08	12"
18	12"	120	159+08	159+32	12"
19	12"	120	159+32	159+56	12"
20	12"	120	159+56	160+00	12"

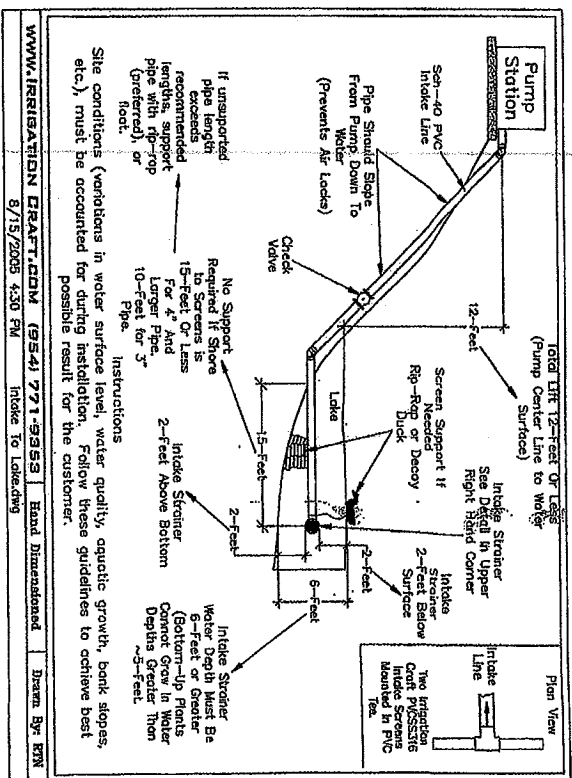

N.T.S.

GRIFFIN ROAD

IRRIGATION PLAN

NOTES AND DETAILS

DRAWN: []

CHECKED: []

DATE: 11/27/09

CCL CONSULTANTS, INC.

ENGINEERS • SURVEYORS • PLANNERS

LANDSCAPE ARCHITECTS • ENVIRONMENTAL CONSULTANTS

1101 11th Street, Suite 100, Phoenix, AZ 85006

PH: (602) 498-9900 FAX: (602) 498-9901

GENERAL NOTES:

4. EXCEPT AS NOTED OTHERWISE, THE IRRIGATION SYSTEM SHALL INCLUDE THE LENGTH OF CP 810 (GRUPPIN ROAD) FROM MOUNTAIN ROAD (S.W. 14TH AVE.) TO PLANTER ROAD (S.W. 12TH AVE). WORK INCLUDES FURNISHING ALL LABOR, MATERIALS, AND EQUIPMENT FOR THE PROPER INSTALLATION OF THE IRRIGATION SYSTEM AND ALL COMPONENTS. THE WORK INCLUDES, BUT IS NOT LIMITED TO THE FOLLOWING: (1) TRENCHING AND BACKFILL, (2) INSTALLATION OF A FULLY AUTOMATED IRRIGATION SYSTEM, (3) WELL CONSTRUCTION AND DEVELOPMENT, (4) INSTALLATION AND ELECTRICAL CONNECTION OF PUMP STATION(S), (5) HYDROSTATIC AND DYE/DYE/DYE TESTS OF ALL SYSTEMS, (6) PREPARATION OF AS-BUILT DRAWINGS.

GENERAL NOTES:

1. ALL PIPES SHALL BE PAINTED FLAT BLACK.
2. THE CONTRACTOR SHALL MAKE ADJUSTMENTS TO THE IRRIGATION SYSTEM TO INSURE 100% COVERAGE AND TO MINIMIZE OVERSPRINK.
3. THE CONTRACTOR SHALL SUBMIT THE IRRIGATION SYSTEM TO THE ENGINEER FOR REVIEW AND APPROVAL PRIOR TO CONSTRUCTION.
4. THE CONTRACTOR SHALL BE RESPONSIBLE FOR HAND WIRING ALL ELECTRICAL, SEWAGE CONNECTIONS.
5. ALL IRRIGATION SLEEVES BELOW ROADWAY PAVEMENT SHALL BE SCH. 40, AND THE COST FOR THESE SLEEVES WILL BE INCLUDED IN THE LUMP SUM COST OF THE IRRIGATION SYSTEM. THE CONTRACTOR SHALL COORDINATE WITH THE ROADWAY CONTRACTOR TO INSURE THAT ALL SLEEVES ARE INSTALLED PRIOR TO CONSTRUCTION OF ROAD, CURBS, AND SIDEWALKS.
6. ALL SLEEVES SHALL BE INSTALLED WITH A 2" SCH. 40 ELECTRICAL SLEEVE FOR THE GENERAL WIRING. (ALSO PROVIDED & INSTALLED BY THE SUBMITTER.)
7. THE CONTRACTOR SHALL BE SOLELY RESPONSIBLE TO CONTACT THE ENGINEER FOR HYDROSTATIC AND OPERATIONAL TESTING.
8. ALL MAIN LINE PIPES PLACED IN SLEEVES SHALL BE SCH. 40 SOLWELD WELD WITH ANGRUITE RESTRAINTS. THE SLEEVE SHALL BE A MINIMUM TWO (2) TIMES LARGER THAN THE ENCLOSED PIPE DIAMETER.
9. ALL COMPONENTS SHOWN AND/OR SPECIFIED ON THE PLAN SHEETS REPRESENT APPROXIMATE LOCATION ONLY, AND ARE FOR CLARIFICATION PURPOSES. THE FINAL LOCATION OF ALL COMPONENTS SHALL BE SUBJECT TO APPROVAL BY THE ENGINEER.
10. CONTRACTOR SHALL PROVIDE POWER SUPPLY FOR IRRIGATION PUMPS IN ACCORDANCE WITH ALL NOTES AND DETAILS. COORDINATE WITH THE POWER AND TELECOMMUNICATIONS DEPARTMENTS. SEE 442-428-4349.
11. IRRIGATION COMPONENT TRADE NAMES ARE SPECIFIED DUE TO REQUEST BY MAINTAINING AUTHORITIES. TOWN OF SOUTHWEST BARRAGES TO INSURE COMPATIBILITY WITH OTHER TOWN SYSTEMS. ALL SUBSTITUTIONS TO MATERIALS SPECIFIED SHALL BE APPROVED BY THE ENGINEER AND THE MAINTAINING AUTHORITY.
12. NOTE CENTERLINE OF CONSTRUCTION IS NOT SHOWN ON THESE IRRIGATION PLANS FOR CLARITY.

UNPAID AS-BUILT PRIOR TO FINAL PAYMENT

At Widdly Remold for Controller

96 overlap

INSPECTION SCHEDULE



DATE	BY	REVISIONS	DATE	BY	REVISIONS
(Seal of the City of Fort Lauderdale, Florida)					
Content Hearing NOTICE OF PUBLIC HEARING FOR THE CITY OF FORT LAUDERDALE, FLORIDA RE: PROPOSED DEVELOPMENT OF THE PROJECT LOCATED AT THE CORNER OF ROAD NO. 818 AND BROWARD ROAD NO. 83-0018					
ROAD NO.	818	ROAD NO.	818	ROAD NO.	818
CORNER	BROWARD	CORNER	BROWARD	CORNER	BROWARD
PROJECT NO.	22108-1-52-01	PROJECT NO.	22108-1-52-01	PROJECT NO.	22108-1-52-01
IRRIGATION NOTES					
SHEET NO. LD-35					

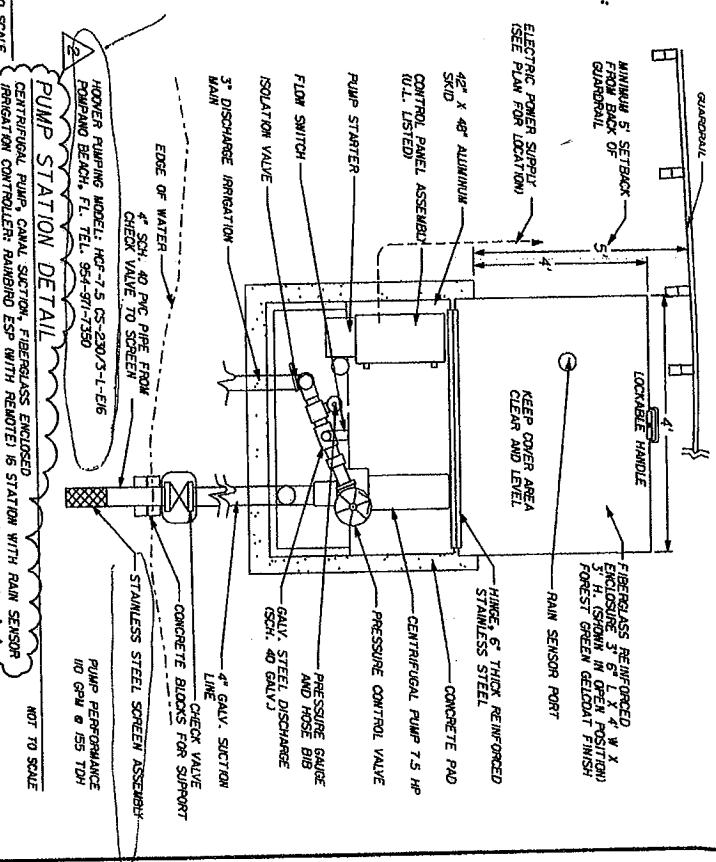
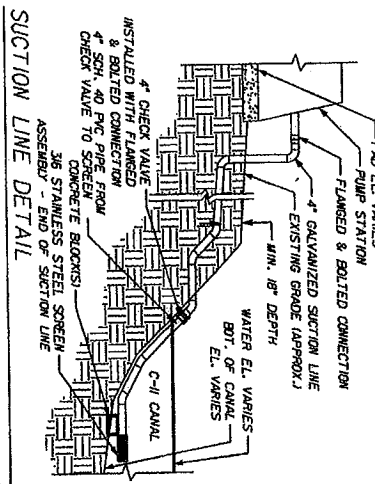
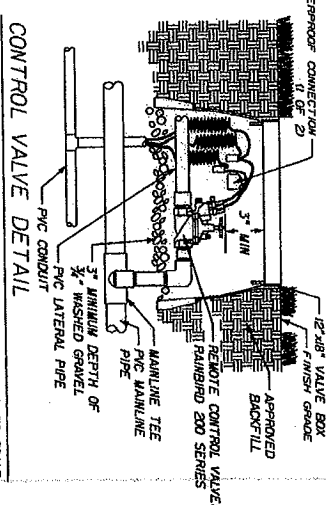
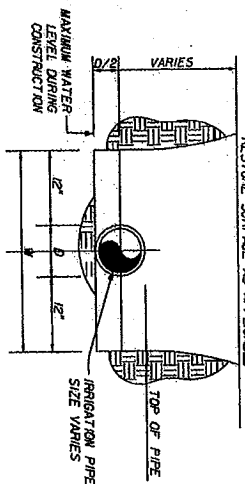
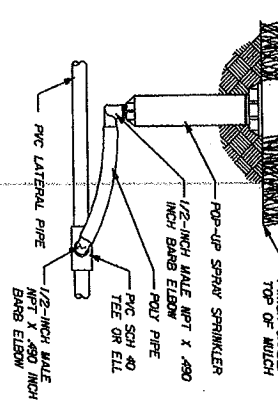
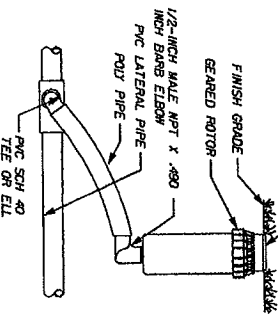
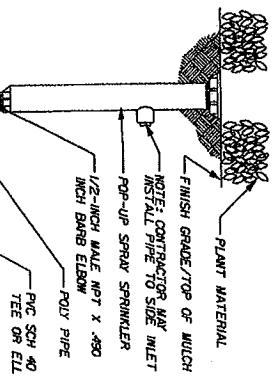

DATE		DESCRIPTION		DATE		REVISIONS	
11/20/07	REV	LANDSCAPE & IRRIGATION REVISIONS					
<p> IRRIAGTON DETAILS SHEET NO. LD-36 STATE OF FLORIDA DEPARTMENT OF TRANSPORTATION COUNTY: BROWARD FINANCIAL PROJECT ID: 227708-1-52-01 ROAD NO.: CR 818 CONTRACT NO.: 227708-1-52-01 DATE: 11/20/07 DRAWN BY: J.M. CHECKED BY: J.M. PROJECT: 227708-1-52-01 SHEET: LD-36 </p>							

SCALE 1/40

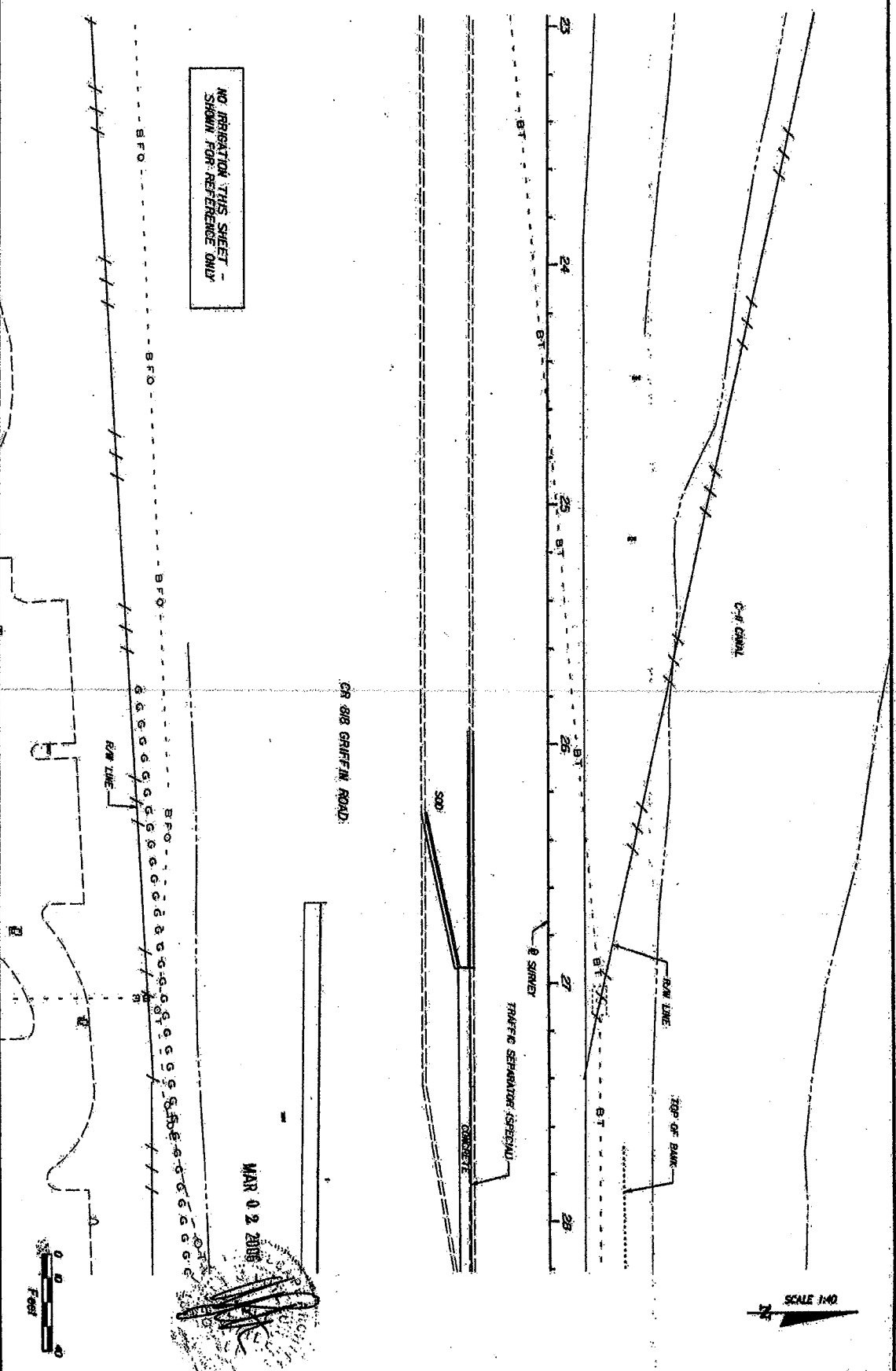

NO IRRIGATION THIS SHEET -
SHOWN FOR REFERENCE ONLY

CR 818 GRUFFIN ROAD

MAR 02 2016



DATE	BY	REVISIONS	DATE	BY	REVISIONS
<p>Professional Seal of Engineer Robert L. Brown, R.L.E., No. 10000 Colleur Heating 1001 Commercial Ave. Suite 100 St. Louis, MO 63103 Phone: 314.433.1234 Fax: 314.433.1235</p>					
<p>STATE OF MISSOURI DEPARTMENT OF TRANSPORTATION COUNTY: CLAY PROJECT NO. 22708-1-52-01 CONTRACT NO. BROWARD</p>			<p>DATE: 02/02/2016 SHEET NO. LD-57</p>		

IRRIGATION PLAN

SCALE 1:40

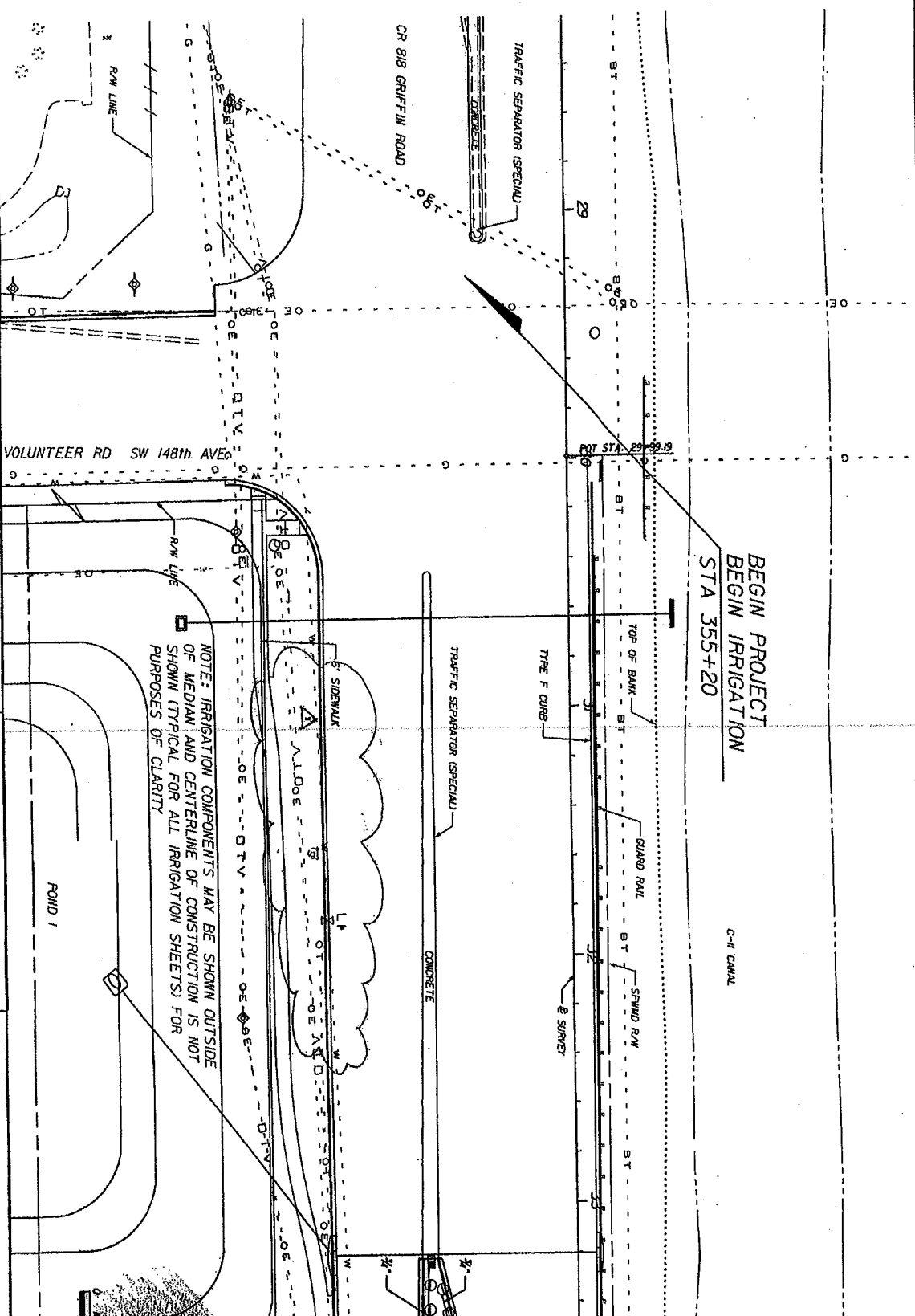

NOTE: IRRIGATION COMPONENTS MAY BE SHOWN OUTSIDE OF MEDIAN AND CENTERLINE OF CONSTRUCTION IS NOT SHOWN (TYPICAL FOR ALL IRRIGATION SHEETS) FOR PURPOSES OF CLARITY

DATE	BY	DESCRIPTION	REVISIONS
3/1/07	RC	Δ Big Bay REMOVED	

DATE	BY	DESCRIPTION

	STATE OF FLORIDA DEPARTMENT OF TRANSPORTATION COUNTY: BROWARD FINANCIAL PROJECT ID: 227708-1-52-01
--	---

ROAD NO.	CR 818
BRAND	BROWARD
FINANCIAL PROJECT ID	227708-1-52-01

SHEET NO.	LD-38
-----------	-------

IRRIGATION PLAN

POND 1

BEGIN PROJECT
 BEGIN IRRIGATION
 STA 355+20

C-H CANAL

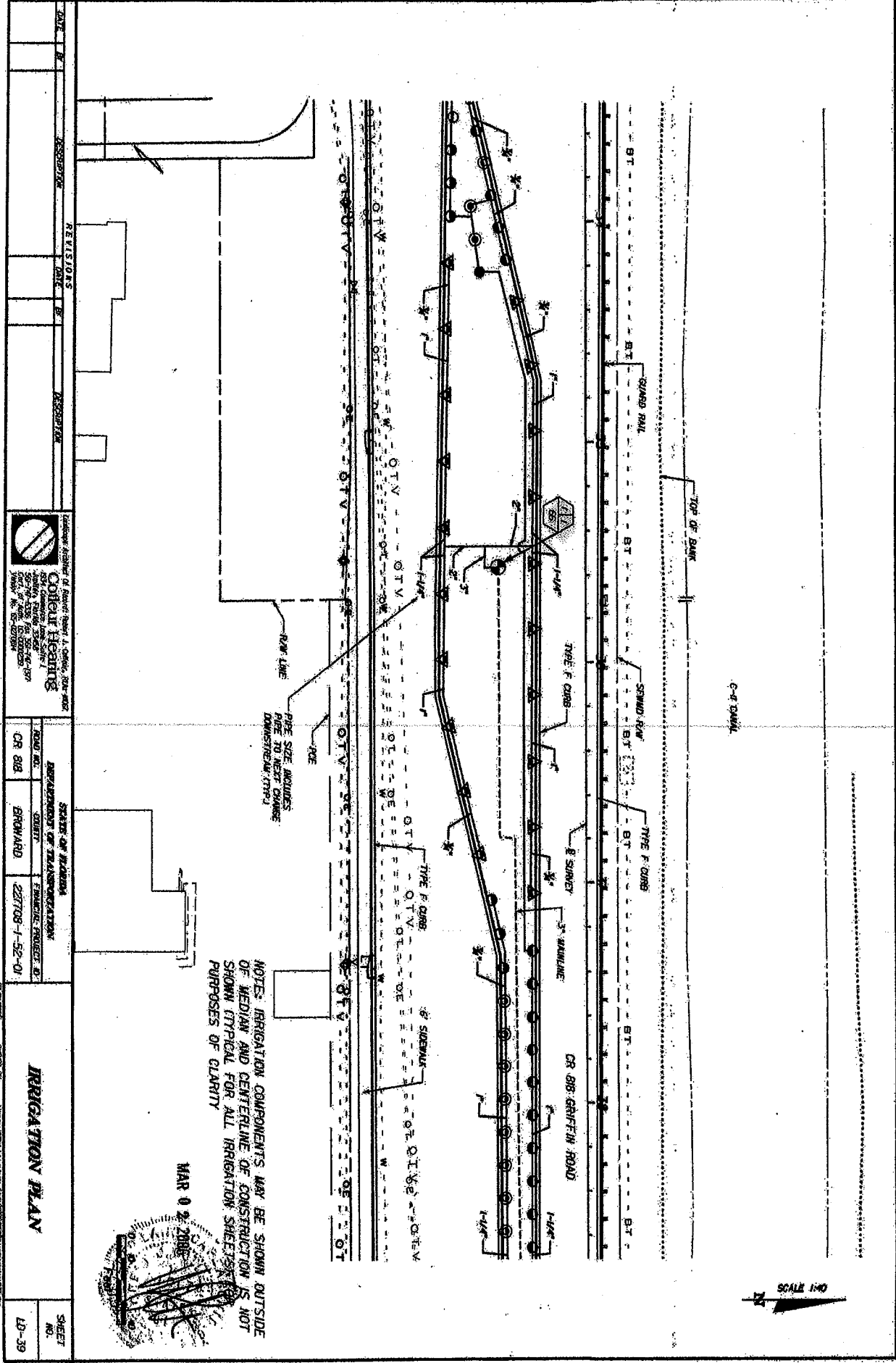

REVISIONS		
NO.	DATE	REVISIONS

COTTELL HOUSING
 524 COMMERCIAL STREET
 MALDEN, MASSACHUSETTS 02148
 PHONE: 617-254-1000
 FAX: 617-254-1000
 WWW: WWW.COTTELLHOUSING.COM

STATE OF MASSACHUSETTS
 DEPARTMENT OF TRANSPORTATION
 OFFICE OF THE DIRECTOR
 227708-1-52-01

IRRIGATION PLAN

SHEET NO. LD-39

NOTES: IRRIGATION COMPONENTS MAY BE SHOWN OUTSIDE OF MEDIAN AND CENTERLINE OF CONSTRUCTION IS NOT SHOWN TYPICAL FOR ALL IRRIGATION SHEETS FOR PURPOSES OF CLARITY

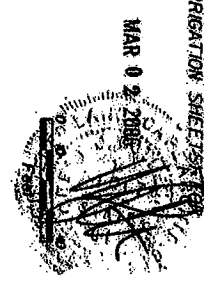

DATE	BY	DESCRIPTION	DATE	BY	DESCRIPTION
8-20-01	RL	LANDSCAPE & IRRIGATION REVISIONS REQUESTED BY CITY			

DATE	BY	DESCRIPTION

PROJECT NO.	CR 818
APPROVED BY	BROWARD
DATE	227708-1-52-01

DATE	BY	DESCRIPTION

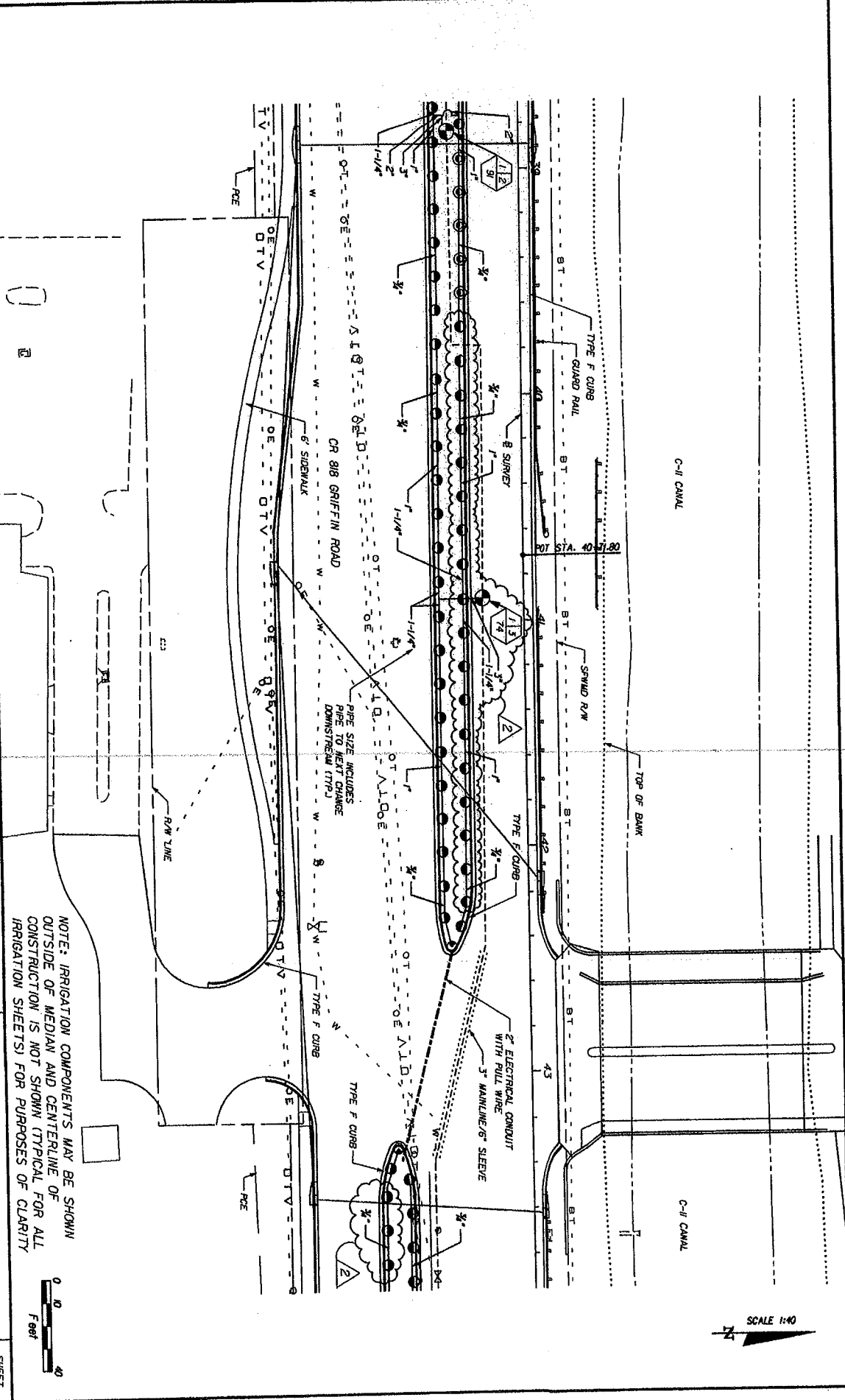

LANDSCAPE ARCHITECT OF RECORD: Robert J. Colony, RLA, M.S.P.
Colony Heading
 5201 S.W. 11th Street, Suite 100
 Fort Lauderdale, FL 33309
 Phone: (954) 574-4333 Fax: (954) 574-1377
 Email: rjcolony@aol.com Website: www.colony.com

STATES OF FLORIDA
 DEPARTMENT OF TRANSPORTATION
 COUNTY: BROWARD
 PROJECT NO.: 227708-1-52-01

IRRIGATION PLAN

SHEET NO. LD-40

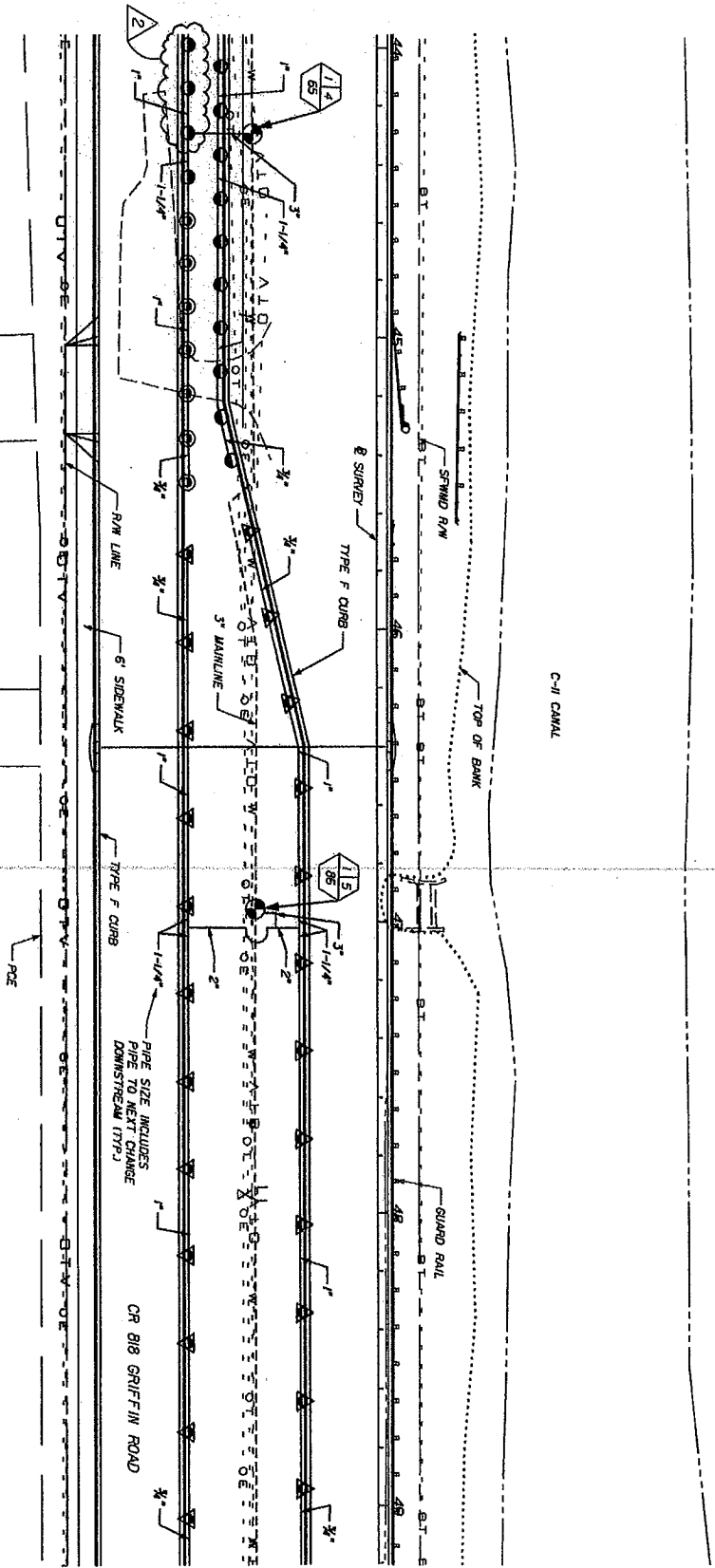

NOTE: IRRIGATION COMPONENTS MAY BE SHOWN OUTSIDE OF MEDIAN AND CENTERLINE OF CONSTRUCTION IS NOT SHOWN (TYPICAL FOR ALL IRRIGATION SHEETS) FOR PURPOSES OF CLARITY



SCALE 1"=40'

DATE		REVISIONS		DESCRIPTION		STATE OF FLORIDA		SHEET	
BY	DATE	NO.	DATE	NO.	DESCRIPTION	DEPARTMENT OF TRANSPORTATION	COUNTY	FINANCIAL PROJECT ID	NO.
BC		1			LANDSCAPE & IRRIGATION REVISIONS REQUESTED BY CITY	BRONARD	BRONARD	227708-1-52-01	LD-41



Robert J. Collier, P.E.

 License No. 4882

 State of Florida

 Expires 12/31/2024

IRRIGATION PLAN

SCALE 1/4" = 10'

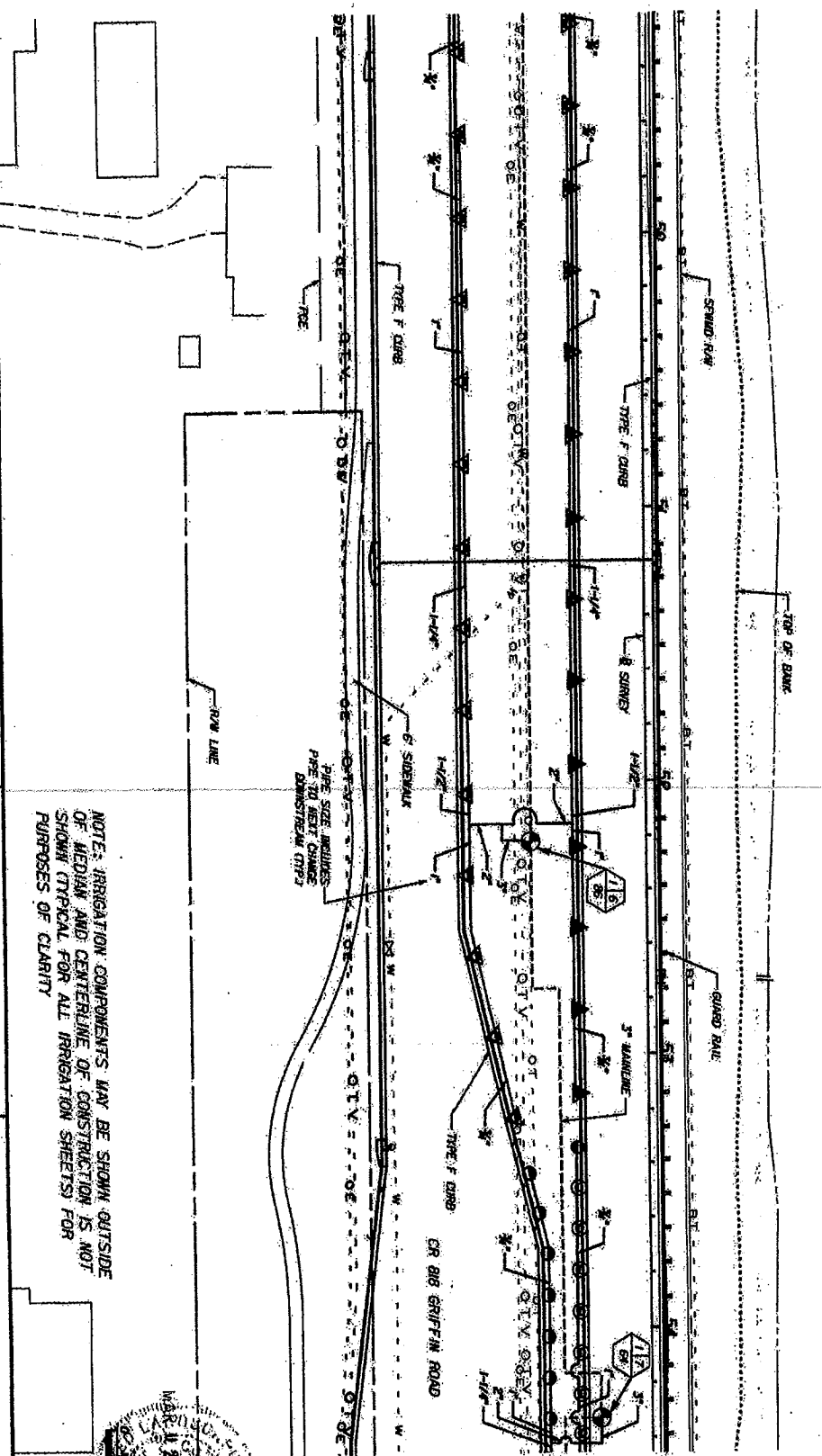

NOTE: IRRIGATION COMPONENTS MAY BE SHOWN OUTSIDE OF MEDIAN AND CENTERLINE OF CONSTRUCTION IS NOT SHOWN (TYPICAL FOR ALL IRRIGATION SHEETS) FOR PURPOSES OF CLARITY

PIPE SIZE INCLUDES PRE TO NEXT CHANGE DOWNSTREAM (1/2")

DATE	BY	REVISIONS	DESCRIPTION

COLETT HIGGINS
 LICENSED PROFESSIONAL ENGINEER
 STATE OF ARIZONA
 LICENSE NO. 10287
 EXPIRES 12/31/2023

STATE OF ARIZONA	DESIGNER	DATE	PROJECT NO.

IRRIGATION PLAN

SHEET NO. 10-42



SCALE 1:40

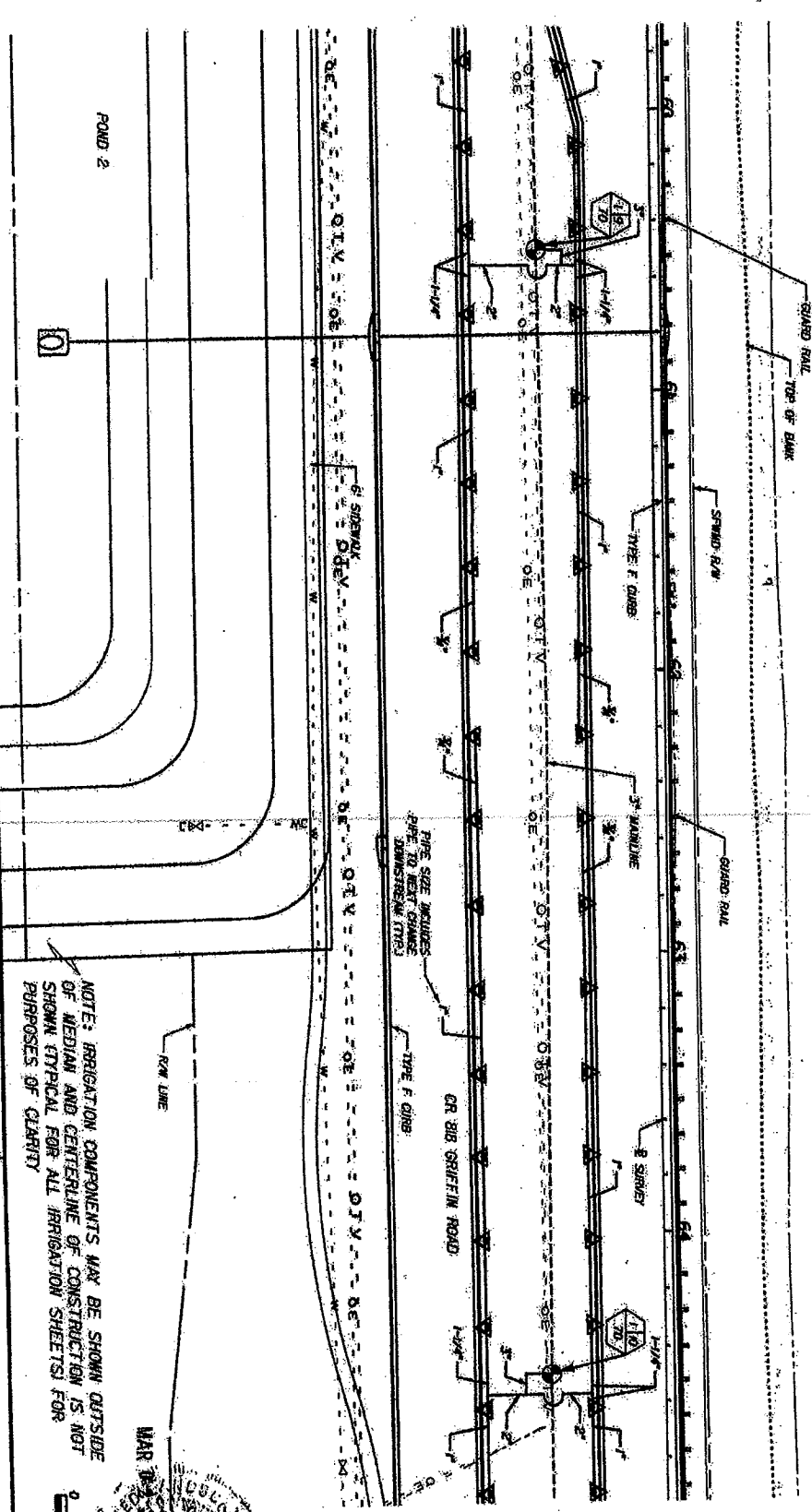

NOTE: IRRIGATION COMPONENTS MAY BE SHOWN OUTSIDE OF MEDIAN AND CENTERLINE OF CONSTRUCTION IS NOT SHOWN TYPICAL FOR ALL IRRIGATION SHEETS FOR PURPOSES OF CLARITY

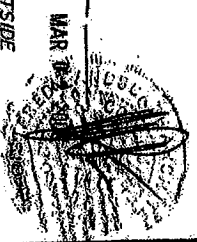

DATE	BY	PROJECT	REVISION
12/22/2023	LD	22171512425	1
ROAD NO.	SECTION	DATE OF PROJECT	SHEET NO.
CR BIG	BROWARD	221708-1-22-01	LD-44
IRRIGATION PLAN			

SCALE 1:40

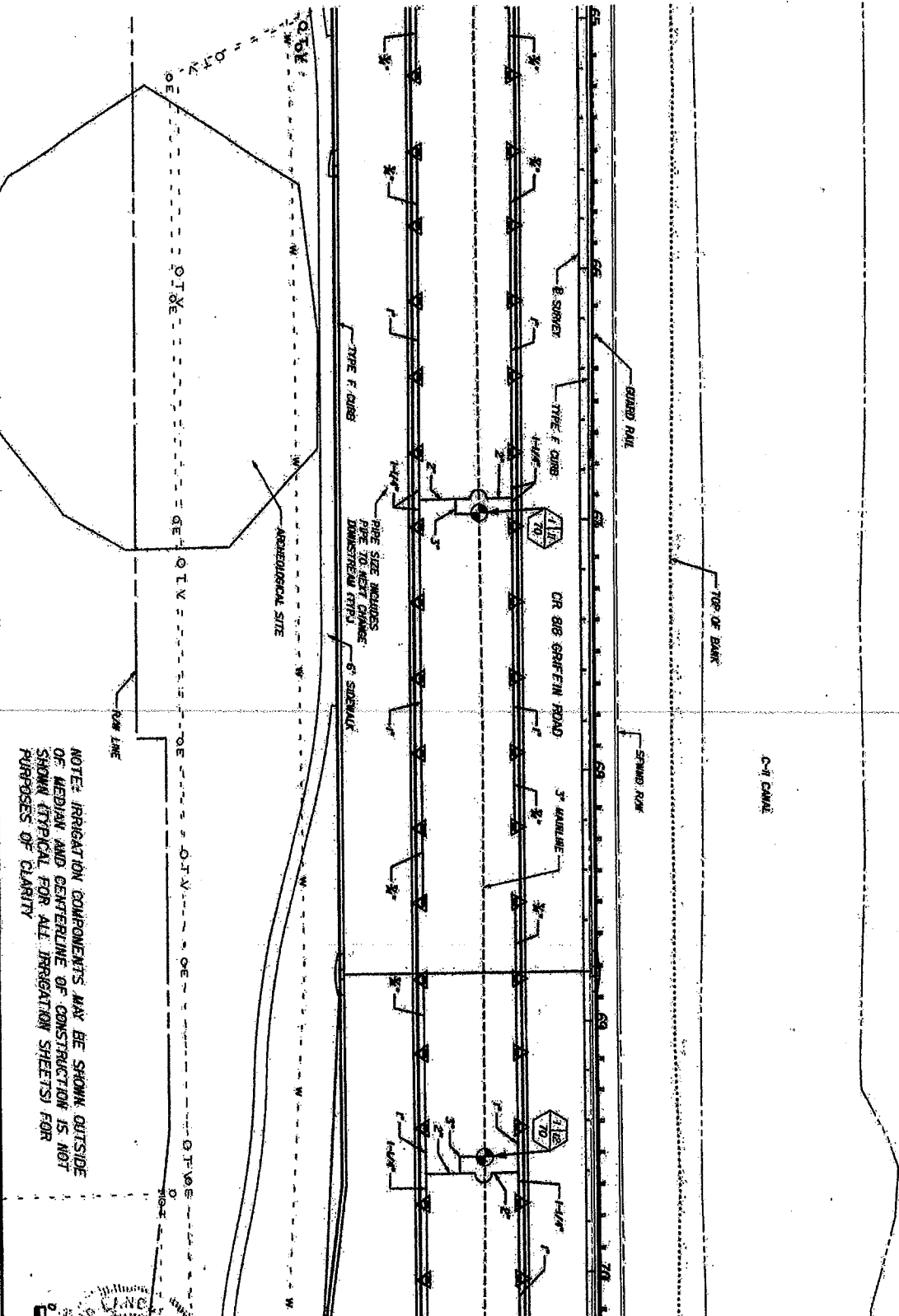

NOTE: IRRIGATION COMPONENTS MAY BE SHOWN OUTSIDE OF MEDIAN AND CENTERLINE OF CONSTRUCTION IS NOT SHOWN (TYPICAL FOR ALL IRRIGATION SHEETS) FOR PURPOSES OF CLARITY



DATE		REVISIONS	PROJECT NO.		SHEET NO.	
 CONTRACT HEARING 505 WEST 10TH AVENUE, SUITE 100 DENVER, CO 80202 TEL: 303-733-1400 FAX: 303-733-1401 WWW.CONTRACTHEARING.COM			STATE OF COLORADO DEPARTMENT OF TRANSPORTATION FEDERAL PROJECT ID CR BIB BROWNARD 28708-1-52-01		IRRIGATION PLAN SHEET NO. LD-45	

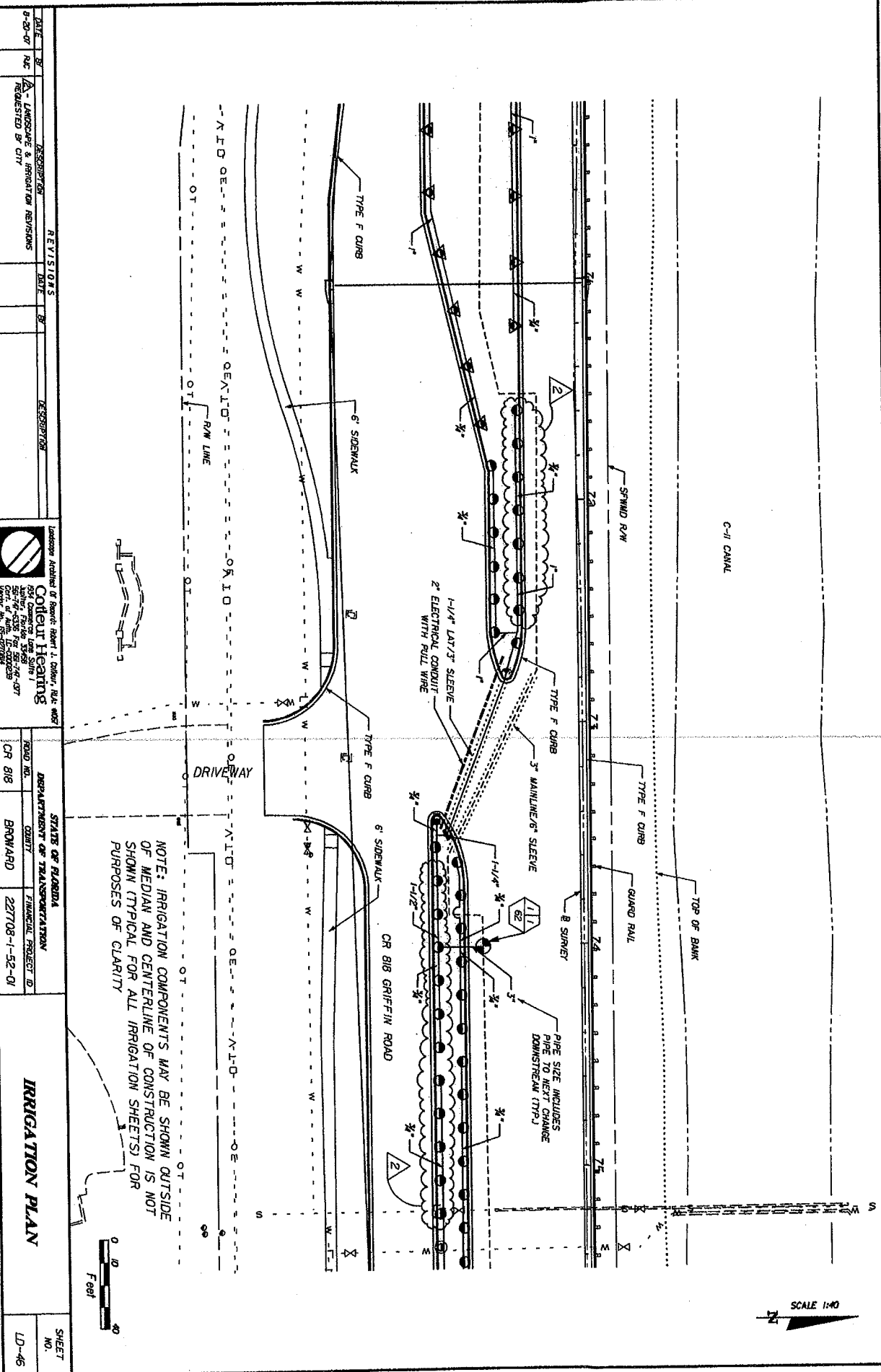

NOTE: IRRIGATION COMPONENTS MAY BE SHOWN OUTSIDE OF MEDIAN AND CENTERLINE OF CONSTRUCTION IS NOT SHOWN (TYPICAL FOR ALL IRRIGATION SHEETS) FOR PURPOSES OF CLARITY

DATE	BY	REVISIONS	DATE	BY
B-20-07	RAC	LANDSCAPE & IRRIGATION REVISIONS REQUESTED BY CITY		

DATE	DESCRIPTION	DATE	DESCRIPTION
06/25/2017			

STATE OF FLORIDA	DEPARTMENT OF TRANSPORTATION	COUNTY	FINANCIAL PROJECT ID
FLORIDA	FLORIDA	BROWARD	2277081-52-01

DATE	SCALE	SHEET NO.
02/27/2017	1:40	LD-46

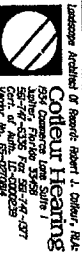

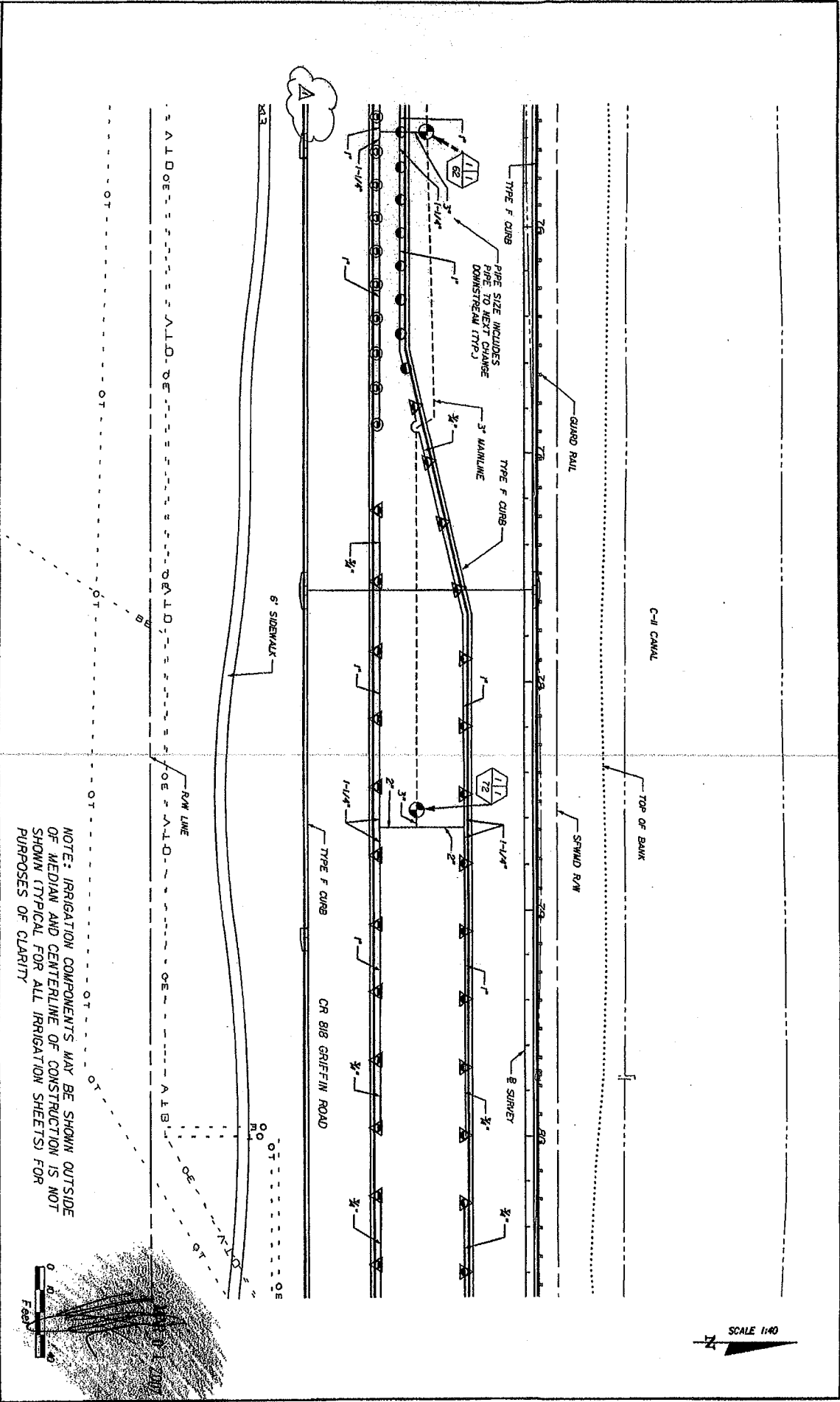

NOTE: IRRIGATION COMPONENTS MAY BE SHOWN OUTSIDE OF MEDIAN AND CENTERLINE OF CONSTRUCTION IS NOT SHOWN (TYPICAL FOR ALL IRRIGATION SHEETS) FOR PURPOSES OF CLARITY



SCALE 1:40

DATE	BY	DESCRIPTION	REVISIONS	DATE	BY	DESCRIPTION
3/10/20	AS	A BUS BAY REMOVED				

		COLLETT HEATHS 834 Commerce Lane, Suite 1 Spring Lake, MI 49782-1377 P.O. Box 16, Addison Mich. 49623-0016	
STATE OF FLORIDA	DEPARTMENT OF TRANSPORTATION	ROAD NO.	FINANCIAL PROJECT ID
COUNTY	BROWARD	CR 818	22708-1-52-01

SHEET NO.	LD-47
-----------	-------

IRRIGATION PLAN

C-3 CANAL

TOP OF BANK

SPREAD ROW

8" SINKET

2" ELECTRICAL CONDUIT WITH FILL WIRE

TYPE F GORE

RAW LINE

SW 135th AVE

GUARD RAIL

TYPE F GORE

CR 818 BRUSHY ROAD

TYPE F GORE

PIPE SIZE INCLUDES PEE TO NEXT CHANGE DIMENSIONS (TYPE)

NOTE: IRRIGATION COMPONENTS MAY BE SHOWN OUTSIDE OF MEDIAN AND CENTERLINE OF CONSTRUCTION IS NOT SHOWN (TYPICAL FOR ALL IRRIGATION SHEETS) FOR PURPOSES OF CLARITY

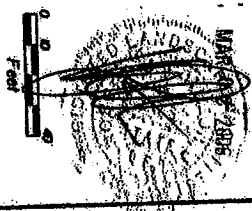

SCALE 1"=40'

DATE	DESIGNED BY	CHECKED BY	APPROVED BY



PROJECT NO.	CR 818
CONTRACT NO.	BROWNARD
DATE	228708-1-52-01

IRRIGATION PLAN

SHEET NO. 1D-48

DATE	DESCRIPTION	REVISED
	REVISIONS	
CONSULTING ENGINEER		
<small>(Professional Engineer License No. 10,000, State of Texas)</small> CONCRETE HEATING <small>1000 WEST 15th AVENUE, SUITE 300, DENVER, COLORADO 80202</small> <small>PHONE: (303) 751-1111 FAX: (303) 751-1112</small> <small>WWW.CONCRETEHEATING.COM</small>		
SCALE	DESIGNATION OF TRANSPORTATION	DATE
CR 818	ROADWAY	22/7/08-1-52-01
IRRIGATION PLAN		
SHEET NO.	LD-49	

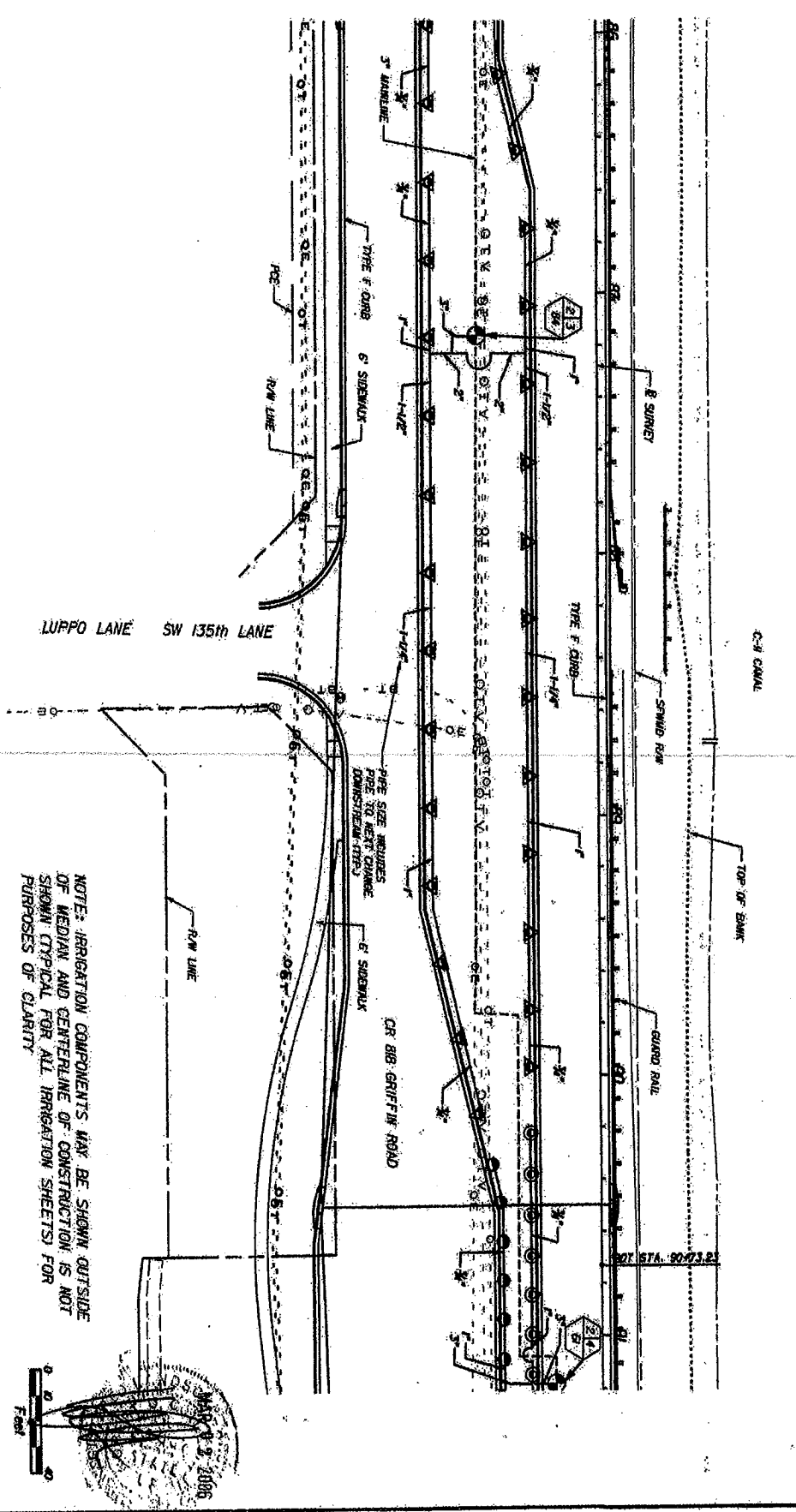

NOTE: IRRIGATION COMPONENTS MAY BE SHOWN OUTSIDE OF MEDIAN AND CENTERLINE OF CONSTRUCTION IS NOT SHOWN (TYPICAL FOR ALL IRRIGATION SHEETS) FOR PURPOSES OF CLARITY

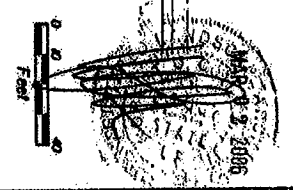

SCALE 1:40

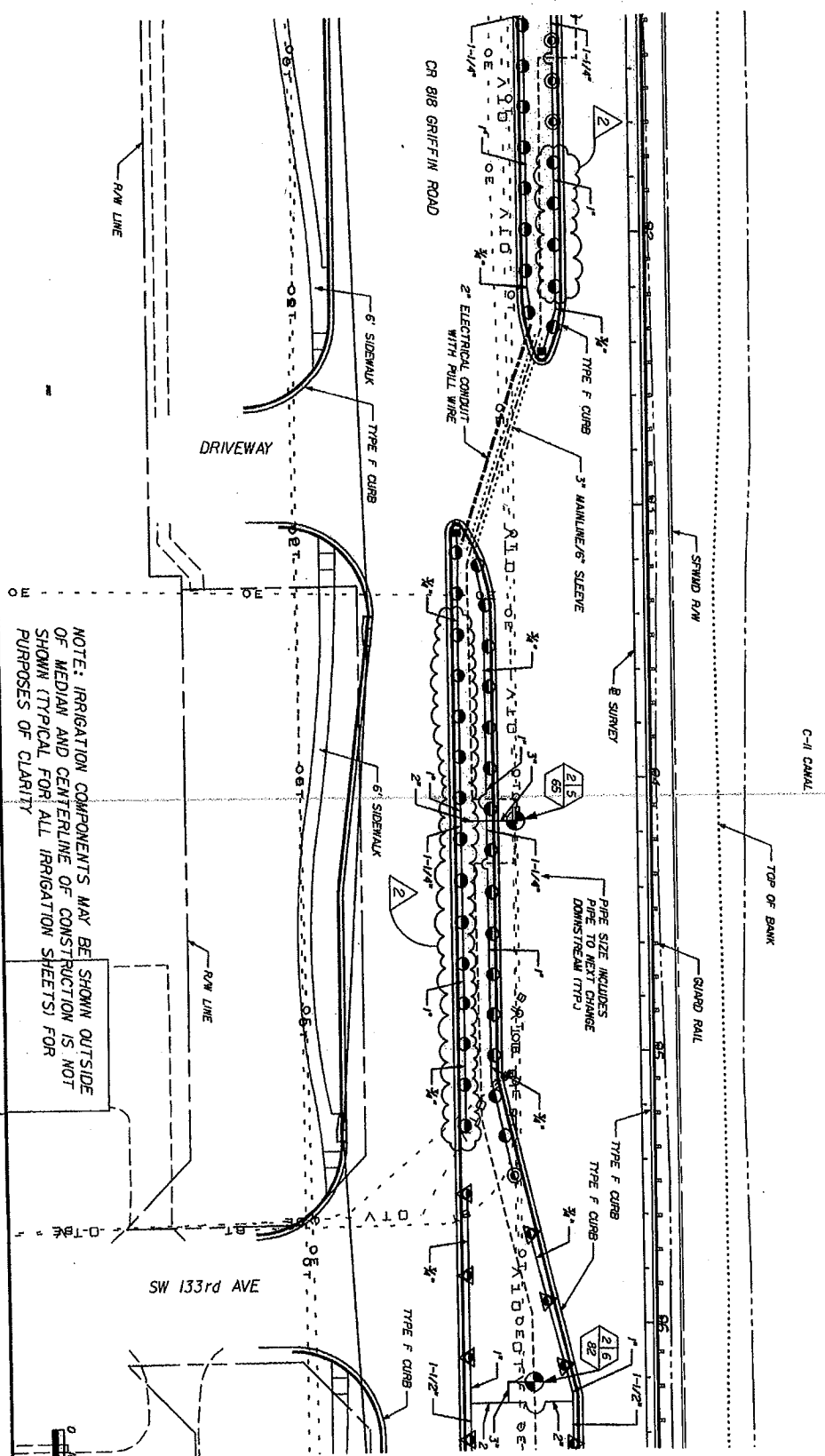

NOTE: IRRIGATION COMPONENTS MAY BE SHOWN OUTSIDE OF MEDIAN AND CENTERLINE OF CONSTRUCTION IS NOT SHOWN (TYPICAL FOR ALL IRRIGATION SHEETS) FOR PURPOSES OF CLARITY

DATE	BY	REVISIONS	DESIGNED	CHECKED	IN CHARGE	STATE OF FLORIDA	DEPARTMENT OF TRANSPORTATION	FINANCIAL PROJECT ID	SHEET NO.
05-20-07	AKC	LANDSCAPE & IRRIGATION REVISIONS REQUESTED BY CITY				LANDSCAPE ARCHITECT OF RECORD Robert L. O'Brien, RLA, No. 1544	STATE OF FLORIDA DEPARTMENT OF TRANSPORTATION	227708-1-52-01	LD-50

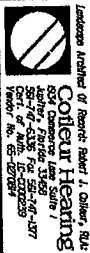

IRRIGATION PLAN

SHEET NO. LD-50

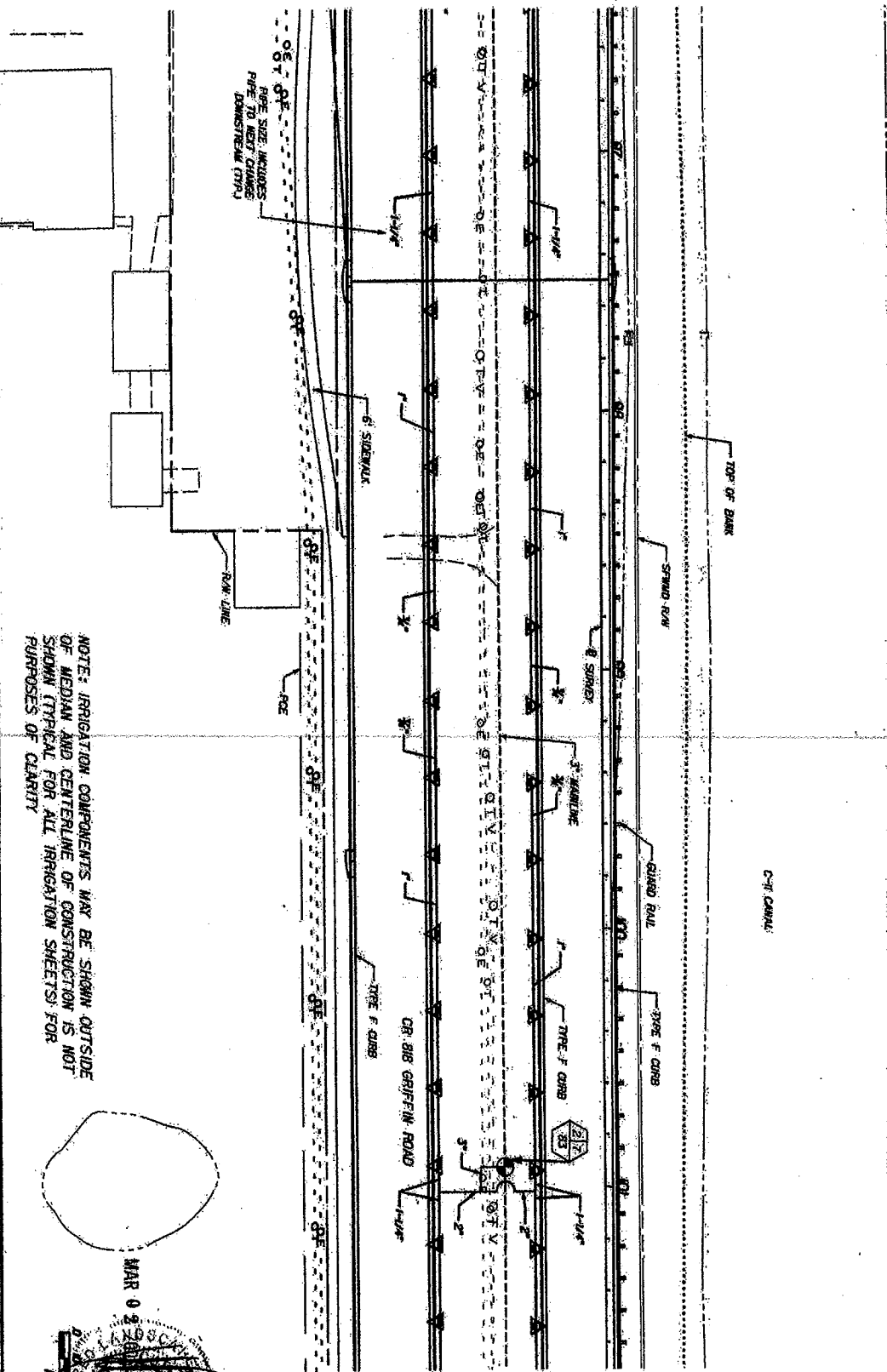

NOTE: IRRIGATION COMPONENTS MAY BE SHOWN OUTSIDE OF MEDIAN AND CENTERLINE OF CONSTRUCTION IS NOT SHOWN (TYPICAL FOR ALL IRRIGATION SHEETS) FOR PURPOSES OF CLARITY

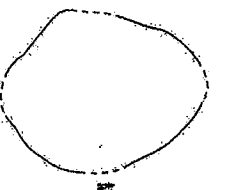

SCALE: 1/4" = 1'-0"

DATE	BY	REVISION	DATE	BY	REVISION
REVISED TO ME					
 COLLETT HEADING COLLETT HEADING 1000 N. G ST. SUITE 100 SACRAMENTO, CA 95811 TEL: (916) 441-1100 FAX: (916) 441-1101 WWW.COLLETTHEADING.COM					
COUNTY OF SACRAMENTO DEPARTMENT OF TRANSPORTATION ROAD NO. 100 BRCKLAND			COUNTY OF SACRAMENTO FINANCIAL PROJECT NO. 227708-1-52-01		
IRRIGATION PLAN					
SHEET NO. 10-51					SHEET NO. 10-51

DATE	REV.	DESCRIPTION	DESIGNER	CHECKER	DATE
REGISTERED PROFESSIONAL ENGINEER CONCRETE HOUSING 1000 S. 10th Street, Suite 100 Phoenix, Arizona 85006 (602) 252-1111			STATE OF ARIZONA DEPARTMENT OF TRANSPORTATION DIVISION OF HIGHWAYS PROJECT NO. 227(08)-1-52-01 CR 818 APPROVED 2/27/08		
IRRIGATION PLAN			SHEET NO. 1D-52		

NOTE: IRRIGATION COMPONENTS MAY BE SHOWN OUTSIDE OF MEDIAN AND CENTERLINE OF CONSTRUCTION IS NOT SHOWN TYPICAL FOR ALL IRRIGATION SHEETS FOR PURPOSES OF CLARITY

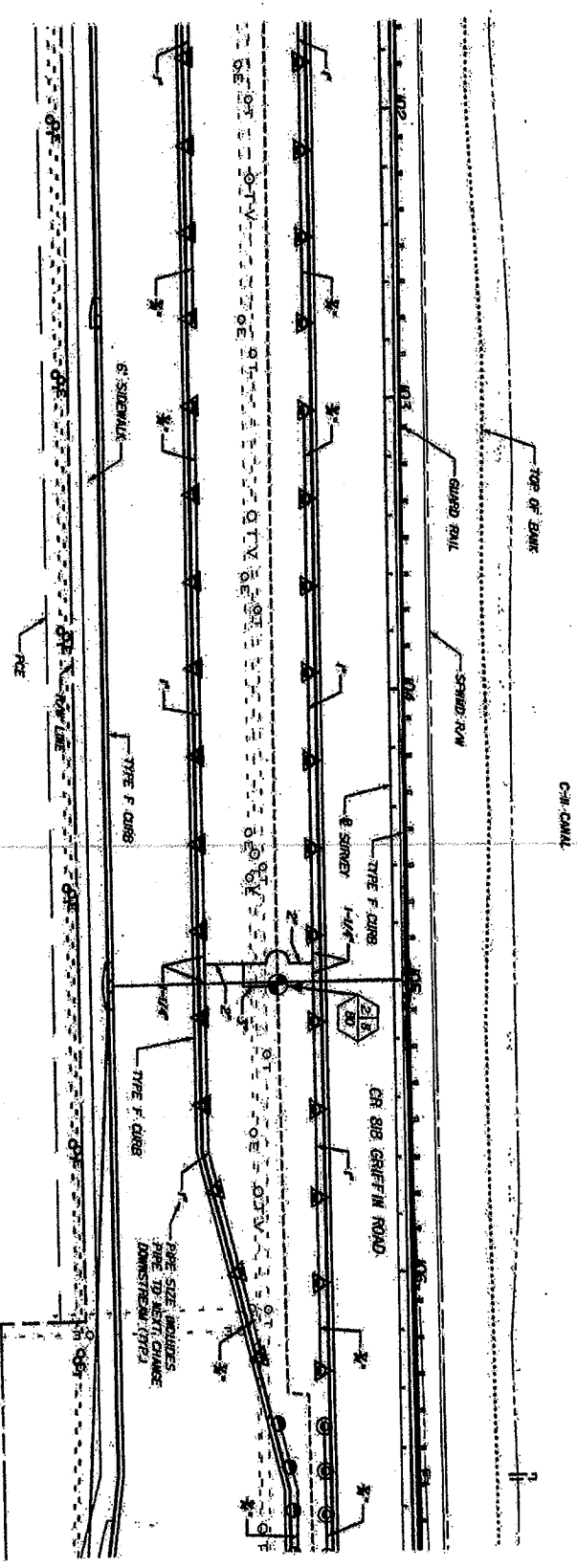

SCALE 1/4" = 1'

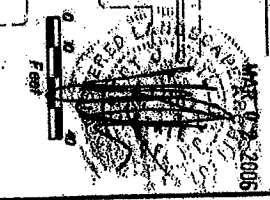

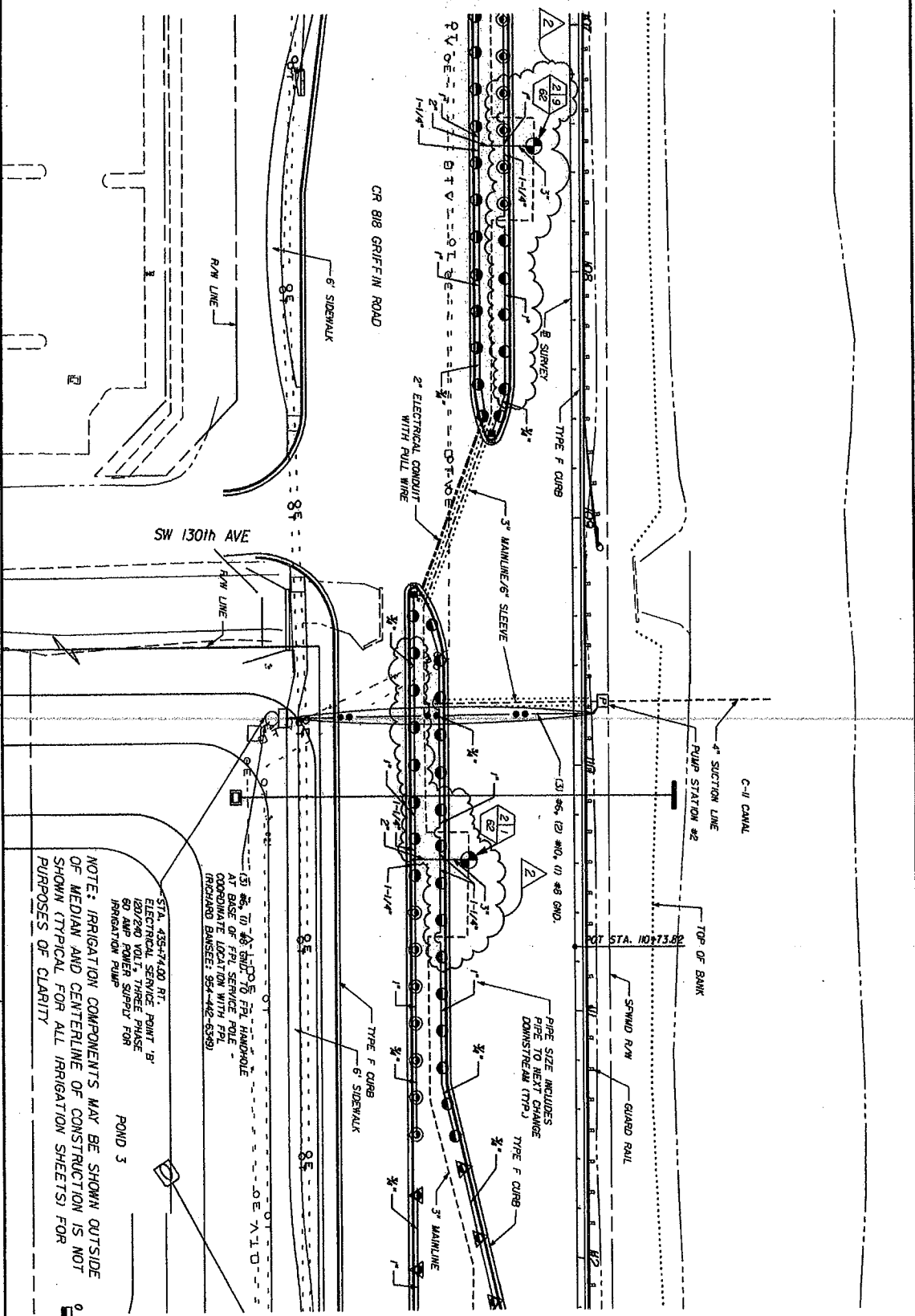

SCALE 1:40

NOTE: IRRIGATION COMPONENTS MAY BE SHOWN OUTSIDE OF MEDIAN AND CENTERLINE OF CONSTRUCTION IS NOT SHOWN (TYPICAL FOR ALL IRRIGATION SHEETS) FOR PURPOSES OF CLARITY



DATE	BY	DESCRIPTION	DATE	BY	DESCRIPTION
B-20-07	RAC	LANDSCAPE & IRRIGATION REVISIONS REQUESTED BY CITY			

<p>Concave Heating 524 Commerce Lane Suite 1 Austin, Texas 78751-3637 P: 512.425.2225 F: 512.425.2225 Vendor No. 55-070584</p>	<p>STATE OF FLORIDA DEPARTMENT OF TRANSPORTATION FINANCIAL PROJECT ID CR 818 BROWARD 22708-1-52-01</p>
--	---

SHEET NO.	LD-53
-----------	-------



C-11 CANAL

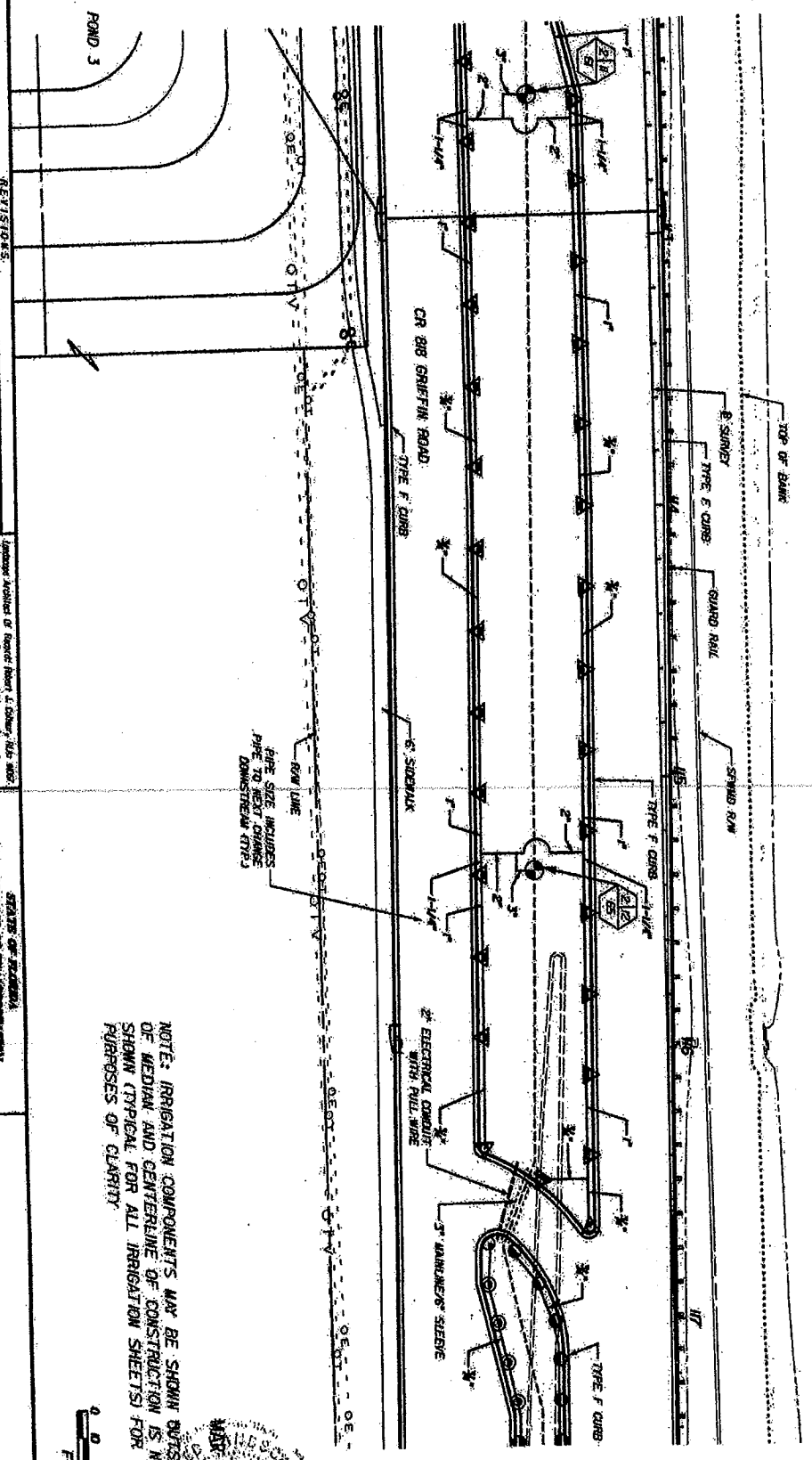

NOTE: IRRIGATION COMPONENTS MAY BE SHOWN OUTSIDE OF MEDIAN AND CENTERLINE OF CONSTRUCTION IS NOT SHOWN (TYPICAL FOR ALL IRRIGATION SHEETS) FOR PURPOSES OF CLARITY.



DATE	BY	REVISIONS	DATE	BY	DESCRIPTION
<p>  CONTACT HEADLINE 14000 W. AVENUE # 100 SUITE 100 WESTLAKE, CA 91361 TEL: (818) 707-1000 FAX: (818) 707-1001 WWW: WWW.CONTRACTHEADLINE.COM </p>					
PROJECT NO.	CR 808	SHEET NO.	LD-54	DATE	2/27/08
COUNTY	BROWARD	PROJECT NO.	227708-1-52-01	DATE	
IRRIGATION PLAN					
SHEET NO.	LD-54				

SCALE 1"=20'

SCALE 1:40

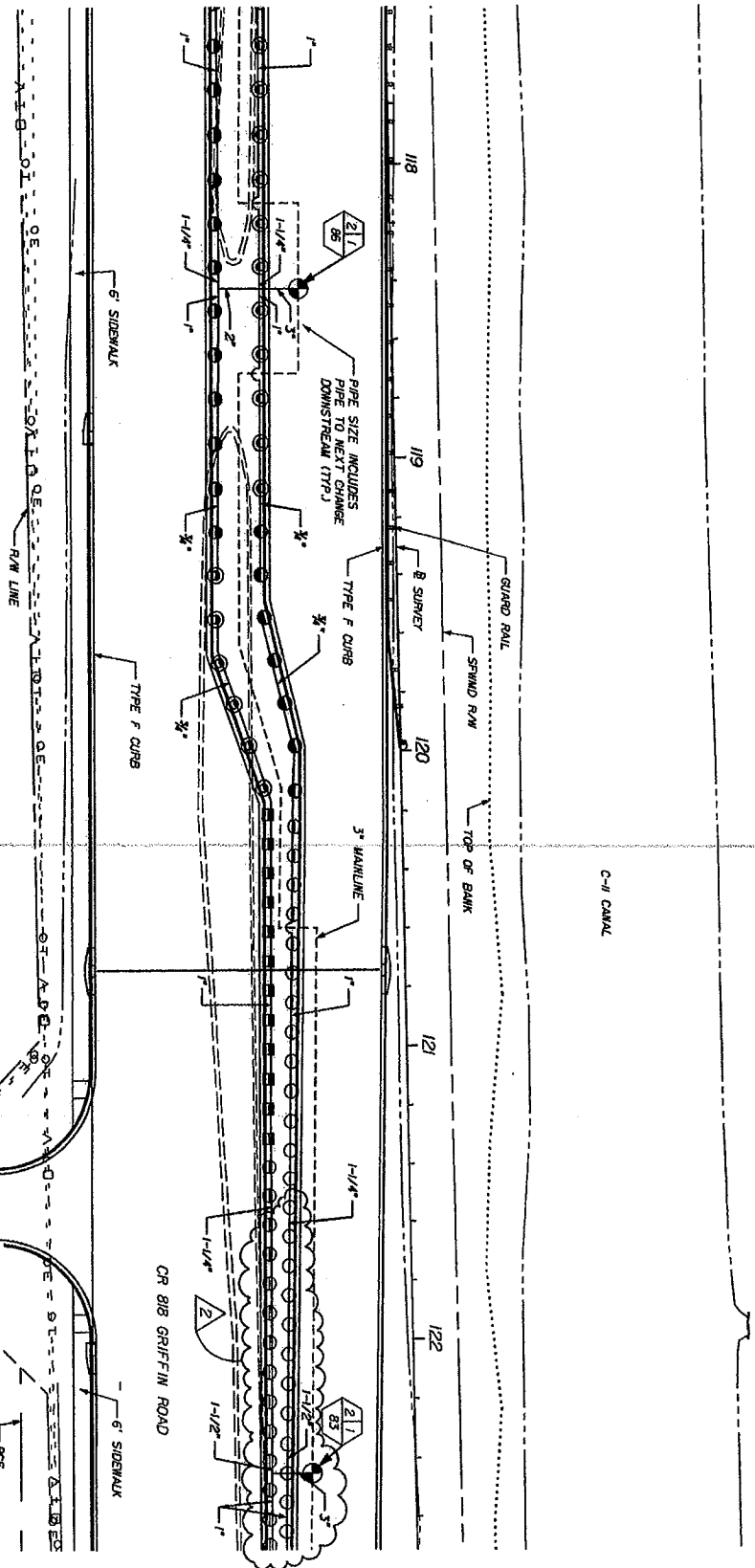

NOTE: IRRIGATION COMPONENTS MAY BE SHOWN OUTSIDE OF MEDIAN AND CENTERLINE OF CONSTRUCTION IS NOT SHOWN (TYPICAL FOR ALL IRRIGATION SHEETS) FOR PURPOSES OF CLARITY



DATE	BY	DESCRIPTION	DATE	BY	DESCRIPTION
8-20-01	RA	DESIGN REVISIONS			
	RA	DESIGN REVISIONS			
	RA	DESIGN REVISIONS			

Landon H. Hester, P.E. Civil Engineer 552 Commerce Lane, Suite 107 Fort Worth, TX 76102 Phone: 817-336-2225 Fax: 817-336-2226		STATE OF TEXAS DEPARTMENT OF TRANSPORTATION COUNTY: TARRANT PROJECT: 22708-1-52-01	
CR 818	BROWARD	22708-1-52-01	

LD-55	SHEET NO.
-------	-----------

DATE	BY	REVISIONS	DATE	BY
2-20-07	LAPOINTE & IRRIGATION REVISIONS			
REQUESTED BY CITY REQUESTED BY CITY REQUESTED BY CITY				
LANSING AREA OF PUBLIC WORKS CIVIL ENGINEERING 501 W. FIFTH ST. SUITE 1000 LANSING, MI 48201				
STATE OF FLORIDA	DEPARTMENT OF TRANSPORTATION	ROAD NO.	CR 818	BROWARD
FINANCIAL PROJECT ID 227703-1-52-01		SHEET NO. LD-56		

NOTE: IRRIGATION COMPONENTS MAY BE SHOWN OUTSIDE OF MEDIAN AND CENTERLINE OF CONSTRUCTION IS NOT SHOWN (TYPICAL FOR ALL IRRIGATION SHEETS) FOR PURPOSES OF CLARITY

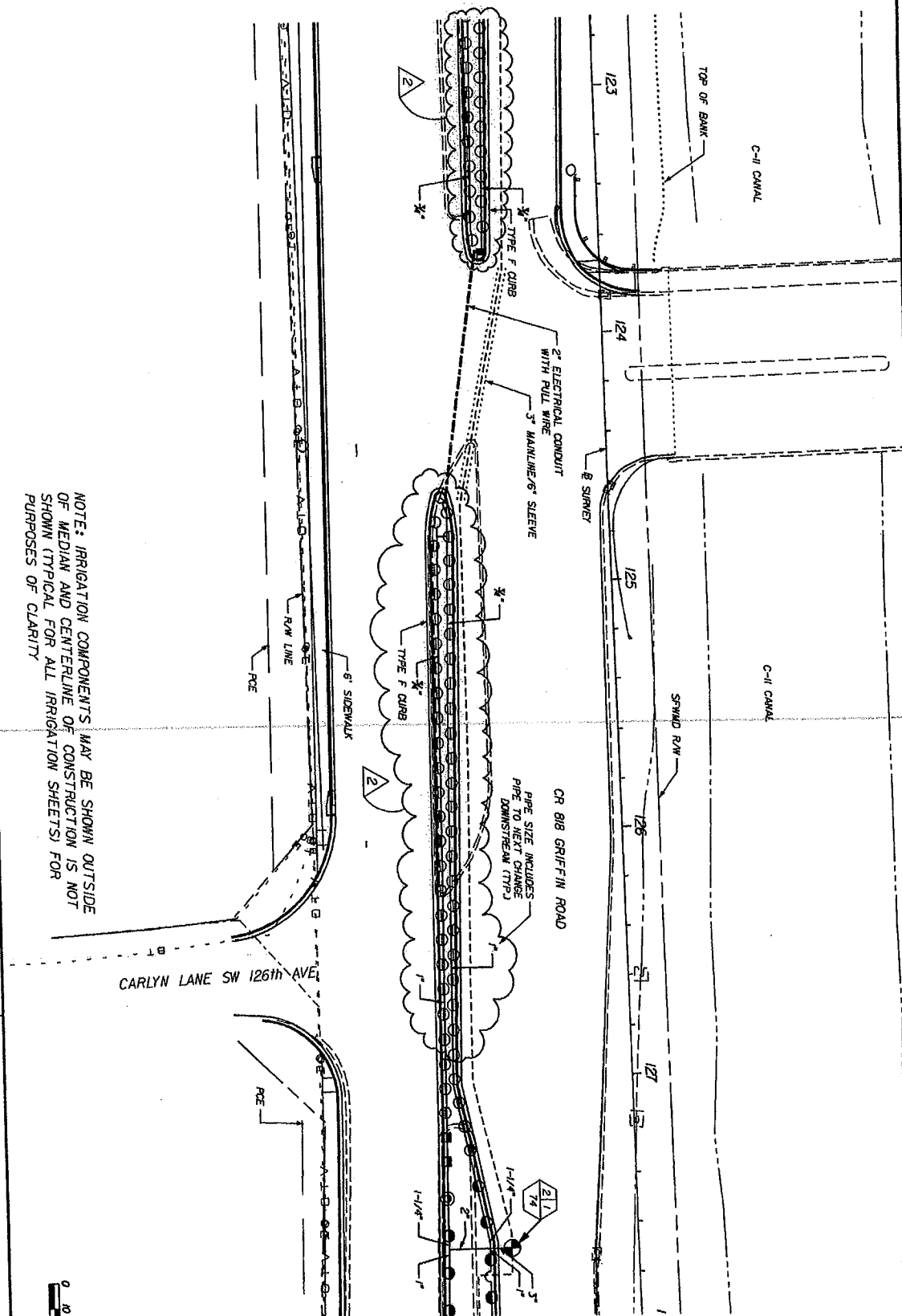
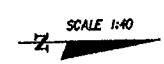
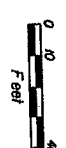

IRRIGATION PLAN

DATE	DESCRIPTION	REVISIONS	DATE	BY

 <p>Collier Heating 1550 S. BIRCH AVE SUITE 101 MEMPHIS, TN 38117 TEL: (901) 683-7000</p>	STATE OF FLORIDA DEPARTMENT OF TRANSPORTATION CONTRACT NO. 227708-1-52-G1 DIVISION OF HIGHWAYS
	IRRIGATION PLAN

ROAD NO. CR 818	COUNTY BROWN	PROJECT NO. 227708-1-52-G1	SHEET NO. 10-57
--------------------	-----------------	-------------------------------	--------------------

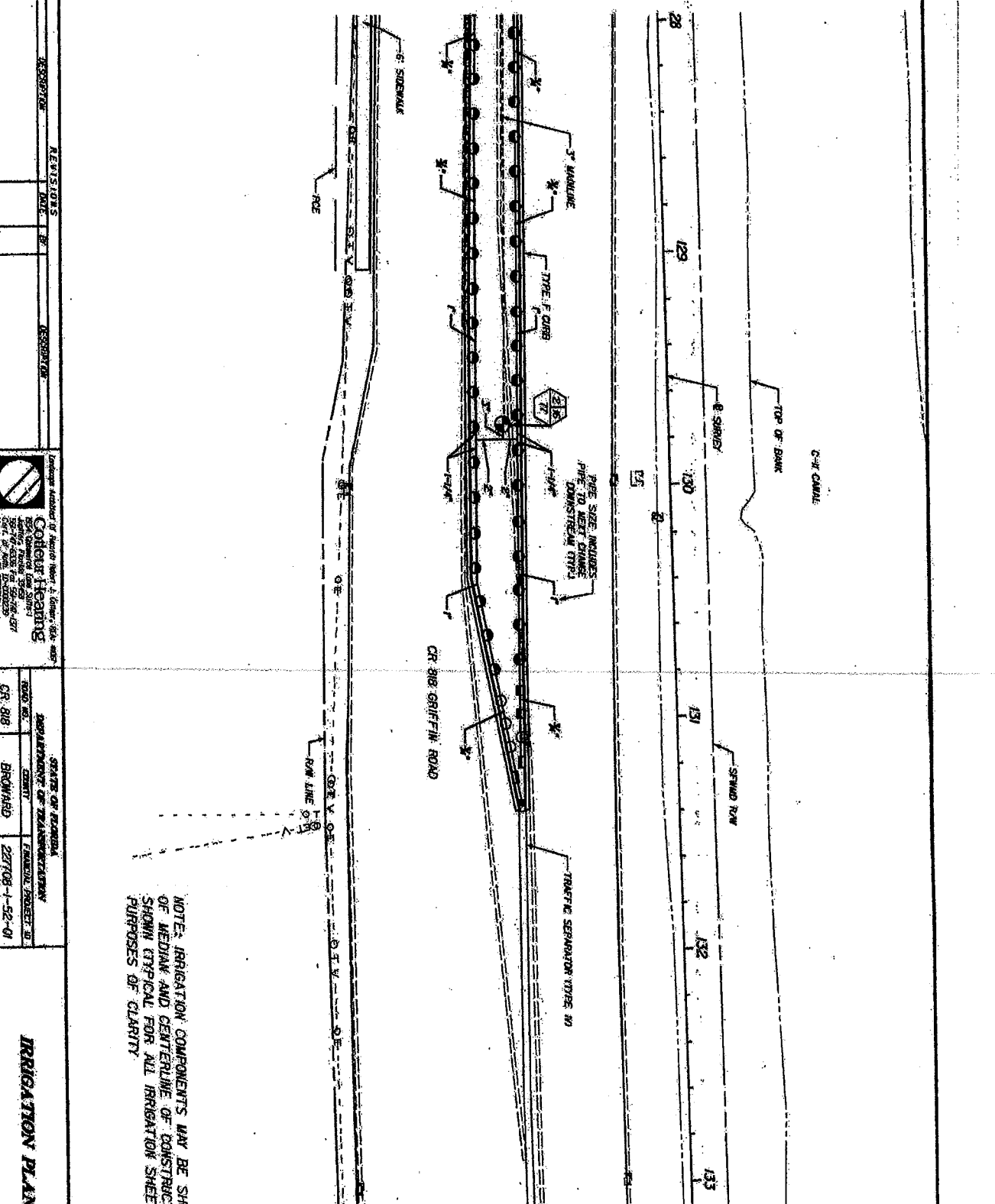

NOTE: IRRIGATION COMPONENTS MAY BE SHOWN OUTSIDE OF MEDIAN AND CENTERLINE OF CONSTRUCTION IS NOT SHOWN (TYPICAL FOR ALL IRRIGATION SHEETS) FOR PURPOSES OF CLARITY.

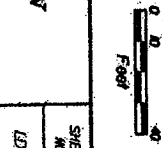

DATE	BY	DESCRIPTION	DATE	BY	DESCRIPTION
5/10/12	PC	A Bus Bay Removed			

 Landscape Architect of Record, Robert L. Collier, PLS, 4828 Robert L. Collier 824 Commerce Line, Suite 1 SW 14th Ave, Suite 100 Fort Lauderdale, FL 33309	DEPARTMENT OF TRANSPORTATION COUNTY OF BROWARD BRONARD 227708-1-52-01
---	--

STATE OF FLORIDA DEPARTMENT OF TRANSPORTATION FINANCIAL PROJECT # 227708-1-52-01	IRRIGATION PLAN	SHEET NO. LD-58
---	------------------------	--------------------

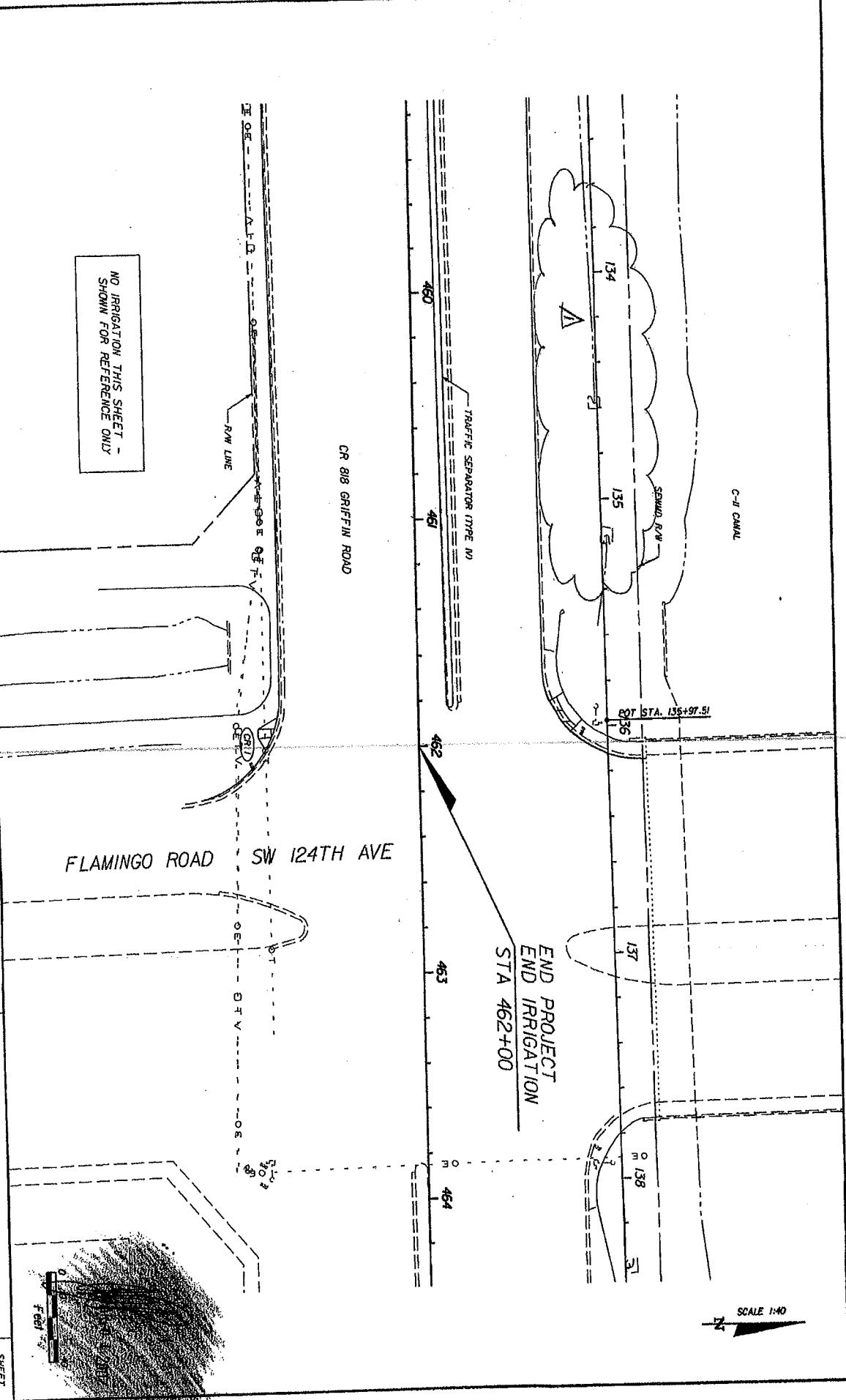

DATE	BY	DESCRIPTION	REVISIONS
			DATE
			BY
			DESCRIPTION
BOYLE			
ENGINEERING CONSULTANTS 100 EAST 70TH STREET, DEPT. 400 CHICAGO, ILL. 60620 AND 1 FIELDS P.L. 171 BURNS RD. 8000			
JOB NO.	DEPARTMENT OR TRADE ORGANIZATION	DESIGNER	CHECKER
CR 818	BROWN	2/27/68	1-52-G1
PROJECT NO.			SHEET NO.
IRIGATION ELECTRICAL SERVICE DETAIL			LD-89

IRRIGATION ELECTRICAL SERVICE POINT WIRING DIAGRAM
(TYPICAL FOR PUMP STATIONS A & B)

NOT TO SCALE

NOTE: COORDINATE ELECTRICAL SERVICE REQUIREMENTS WITH LOCAL POWER AND LIGHT REPRESENTATIVE
FORWARD BRIDGE 2954-42-6240

